

Rated Merv 7

Breathe Easy™ Microparticle Air Filters

7X More Effective Than Ordinary A/C Filters



Key Benefits

- Rated Merv 7 - 7X more effective at capturing airborne microparticles than ordinary foam and mesh filters
- Capture fumes, odors, dust, lint, and pet dander
- Electrostatically-charged fibers attract and retain microparticles that pass through the filter
- Easy installation for all types and models of Marine Air air conditioning systems
- Custom sizes available

Enjoy cleaner, healthier air quality on your boat with Breathe Easy™ microparticle, anti-allergenic air filters for your air conditioning system. Breathe Easy microparticle air filters are rated Merv 7, making them seven times more effective than ordinary air filters.

Breathe Easy microparticle air filters are efficient and disposable, and are available for most Dometic air conditioning systems. Installation takes only seconds using the existing brackets on either side of the evaporator face. Special pins are included to hold the air filter in place on units which do not have these brackets.

Because Breathe Easy microparticle air filters are highly efficient in removing impurities, they should be changed at frequent intervals to maintain air quality. Dometic recommends changing the filter once every two months when living aboard, once every four months when the air conditioner is used three weekends per month, and once every six months when the air conditioner is used only one or two times per month.

Complete installation and replacement instructions are provided in the air filter packaging.



Breathe Easy microparticle air filters are easy to remove...



...and install.



Technical Specifications for Breathe Easy™ Microparticle Filters

| Filter P/N ⁽¹⁾ | Fits Cruisair A/C Models | Fits Marine Air A/C Models | Fits Dometic A/C Models | Width x Height (in) | Width x Height (mm) |
|---------------------------|--|---|-------------------------|---------------------|---------------------|
| 235000600 | SXF5, SXF5-1, SHF5, SHF5-1, ZF5, ZF5-1 | VCD5K/1, VCP5K, VCM5K, VCM5K/1, CLM5KC, CLM5KC/1 | ECM5, ECD5 | 7-7/8 x 9 | 200 x 229 |
| 23500060 | SXF7, SXF7-1, SHF7, SHF7-1, SXR7-1, SHR7-1, SXR10, SHR10, SXR12, SHR12 | VCD7K/1, VCP7K, VCM7K, VCM7K/1, CMCD7K/1, CMCM7K, CMCM7K/1 | ECM6.5, ECD6.5 | 9-3/8 x 10 | 238 x 254 |
| 23500060 | SXR7, SHR7 (old style 7K), ZF3.5 | CD3.5, SVCM3.5, CLM3.5 | N/A | 8-1/8 x 8 | 206 x 203 |
| 23500060 | SXF10-1, SHF10-1, ZF10-1 | VCD10K/1, VCM10K/1, CLM-10KC/1, CMCD10K/1, CMCM10K/1 | ECM9, ECD9 | 10-7/8 x 10 | 276 x 254 |
| 235000604 | SXF10, SHF10, ZF10, ZF12 | VCP10K, VCM10K, CLM10KC, CLM12KC, CMCP10K, CMCM10K | N/A | 11-7/8 x 10 | 302 x 254 |
| 235000605 | SXF12-1, SHF12-1, SXF16-1, SHF16-1, ZF12-1, SXR16, SHR16, ZF16-1, STX14, STX16, STQ14, STQ16, STH14, STH16 | VCD12K/1, VCM12K/1, CLM-12KC/1, CMCD12K/1, CMCM12K/1, VCD16K/1, VCM16K/1, CLM16KC/1, CMCD16K/1, CMCM16K/1, VTD14, VTD16, VTM14, VTM16 | ECM11, ECD11 | 10-7/8 x 12 | 276 x 305 |
| 235000606 | SXF12, SHF12, SXF16, SHF16, SXF18, SHF18, ZF16 | VCP12K, VCM12K, VCP16K, VCM16K, VCD18, CLM16KC, CMCP16K, CMCM16K | ECM15, ECD15 | 11-7/8 x 12 | 302 x 305 |
| 235000607 | SXF24, SXF24-1, SHF24, SHF24-1 (special order) | VCD24K/1, VCP24K, VCM24K, VCM24K/1 (special order) | N/A | 16-3/8 x 16 | 416 x 406 |
| 235000608 | SX24, SH24 (special order) | N/A | N/A | 15-1/8 x 17 | 384 x 432 |
| 235000638 | STX6, STX8, STQ6, STQ8, STH6, STH8 | VTD6, VTD8, VTM6, VTM8 | N/A | 8-7/8 x 10-1/4 | 226 x 261 |
| 235000639 | STX10, STX12, STQ10, STQ12, STH10, STH12 | VTD10, VTD12, VTM10, VTM12 | N/A | 10-7/8 x 11-1/2 | 276 x 293 |
| 235000700 | N/A | N/A | ECD6 | 7-7/8 x 9 | 200 x 229 |
| 235000703 | N/A | N/A | ECD10, ECD16 | 10-7/8 x 12 | 276 x 305 |

¹ Please pay close attention to AC models 10, 12, and 16, and whether or not they have the suffix "-1" or "/1" in the model number. Additionally, unit filters for all 5-16K models with the suffix "-1" and "/1" unit filters are interchangeable with "-2" and "/2" units.

Decide What Size You Need

Locate the data plate on the air conditioning unit to find its model number, then use the table above to match the model number to the correct filter P/N. If the model number is not listed above, measure the unit's evaporator face and find the filter P/N in the table with matching dimensions.

Dimensions

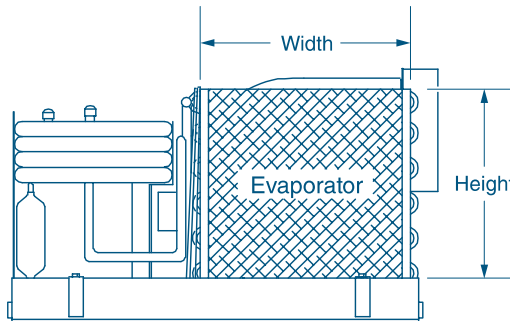

DOMETIC MARINE DIVISION

2000 N. Andrews Ave. Ext. | Pompano Beach, FL 33069 USA | Tel. 954-973-2477 | Fax: 954-979-4414
 www.Dometic.com/Marine | MarineSales@DometicUSA.com

24/7 TECH SUPPORT FOR UNITED STATES & CANADA:

8:00 AM to 5:00 PM Eastern Time: 800-542-2477
 After hours and weekends: 888-440-4494

INTERNATIONAL SALES & SERVICES

Europe & the Middle East: Call +44(0)870-330-6101
 For all other areas visit our website to find your nearest distributor.

Dealer



Reduce Startup Amps by 65%

SmartStart™ II Soft Starter

Eliminate Boat Air Conditioning Start-Up Spikes

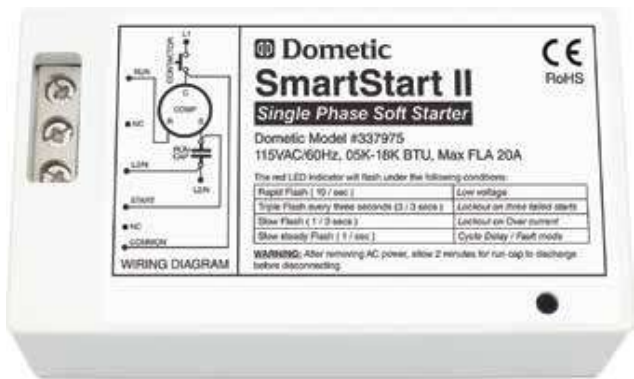

The SmartStart™ II is a unique device that smooths out startup power demand of the boat air conditioner's compressor, reducing amp requirements by up to 65%. The technology uses dynamic feedback control to reduce the inrush of current by starting the compressor motor slowly, thereby eliminating current surges that could affect the operation of an overstraining power source. No other soft starter in the industry provides better performance.

In some situations, this gentler method of handling the power surge can mean the difference between keeping the generator you have or investing thousands of dollars in a larger one. For boats without a generator, SmartStart II may allow the option of powering an air conditioning system from an inverter, and when running on dock power, it may resolve issues where the power source or connection may be weak.

Not only does the SmartStart II ease strain on the power source, it's also less stressful for the compressor itself. Additionally, it provides valuable protection by shutting down the compressor if the power source or the connection to the compressor is briefly interrupted (it will attempt a soft start after three minutes).

New to the SmartStart II is a red LED indicator that flashes codes for fault conditions that can cause SmartStart II to shut down the compressor in the event of low voltage, over current, intermittent power loss, incorrect wiring at installation, and other faults. SmartStart II also makes wiring easier with a new type of termination block.

All this power comes in a surprisingly small package. At only 5 x 3 x 2 in. (127 x 76 x 51 mm), the SmartStart II takes up little space and weighs only 15 oz. (0.43 kg.). It is wired directly into the air conditioning system's electrical box.

SmartStart II reduces compressor startup power demand by up to 65%.

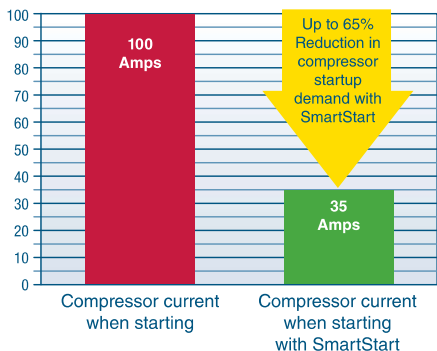

Key Benefits

- Reduces strain on the power source
- Reduces brown-out effects at compressor start-up
- May enable an inverter to power the air conditioner
- May eliminate the need to upgrade the generator
- Fault-code LED provides troubleshooting assistance
- Easier wiring with new termination block
- Inexpensive, small, and lightweight

Product Testimonial

"The generator's control circuit would trip and stop the generator due to the inrush of the Emiko's heat pump. The SmartStart reduced that inrush of current so the generator would continue to run.

We started with an inrush of 77 amps and finished with an inrush of only 20 amps. [The SmartStart] is a great solution to our problem."

— Mr. John Poole, Poole Refrigeration Service, Alameda, CA, M/V Emiko (37 ft. Nordic Tug)



Specifications for SmartStart™ II Soft Starter

| Model ⁽¹⁾ | 337975 | 337976 | 337977 |
|----------------------------------|-------------------|-------------------------|-------------------------|
| Min. Volts/Max. Volts/Cycle | 115 V/50 Hz/60 Hz | 208 V/240 V/50 Hz/60 Hz | 208 V/240 V/50 Hz/60 Hz |
| Supported Comp. Capacity (BTU/h) | 5000/18000 | 12000/30000 | 36000/60000 |
| Max. FLA (A) | 20 | 16 | 32 |

¹ Typical start surge reduction as compared to compressor locked rotor ampere (LRA) is 65%

Dimensions

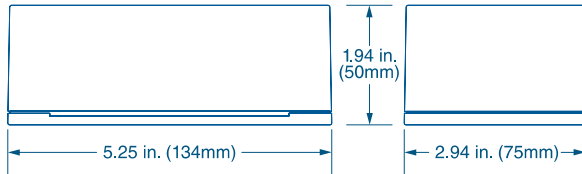

Optional SmartStart II Mounting Tray

Model #4220045 (pictured below)



Wiring Diagram

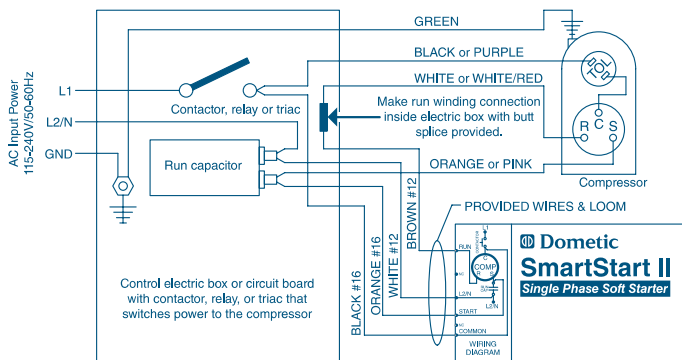

DOMETIC MARINE DIVISION

2000 N. Andrews Ave. Ext. | Pompano Beach, FL 33069 USA | Tel. 954-973-2477 | Fax: 954-979-4414
 www.Dometic.com/Marine | MarineSales@DometicUSA.com

24/7 TECH SUPPORT FOR UNITED STATES & CANADA:

8:00 AM to 5:00 PM Eastern Time: 800-542-2477
 After hours and weekends: 888-440-4494

INTERNATIONAL SALES & SERVICES

Europe & the Middle East: Call +44(0)870-330-6101
 For all other areas visit our website to find your nearest distributor.

L-3486 Rev. 20150403

Specifications and availability subject to change without notice.

Dealer



NEW

WhisperFan Controller

Silences Noisy AC-Driven Blower Motors



The WhisperFan Controller eliminates the noise generated by AC-driven blower motors at low fan speed settings. In addition, it provides overload protection to the blower motor and lets you precisely control the actual fan speed for each fan-speed setting (e.g. High, Medium, Low).

This electrical device uses pulse width modulation to make any AC-driven fan as quiet as a DC-driven fan. Simply install it in line between the electrical box and the blower. By pulsing the voltage hundreds of times faster than is possible with triacs, the smoother motor current results in quieter, extreme low-noise output across all fan speeds.

The WhisperFan Controller also provides more versatile fan-speed control. Want a more noticeable difference between your fan's medium speed and its high speed? The WhisperFan's two-button keypad allows you or an installer to specify the exact speed for all your fan speed settings. Further fine tuning can be done later from your cabin control's keypad (e.g. Cruisair Qht or Marine Air Systems Elite).

The WhisperFan works with all Cruisair and Marine Air cabin controls (Q-Logic, Passport, and SMXII) and with any AC blowers on either chilled water or direct expansion air conditioning systems.

The WhisperFan Controller is an easy and economical solution for an existing blower installation that may be too noisy. It's also great for anyone who wants to make precise adjustments to the fan-speed settings.

The WhisperFan Controller works with blowers up to 3 amps. WhisperFan can only support a single blower, so you must use one per fan.



The WhisperFan Control two-button keypad allows the boat owner or installer to adjust fan speed settings.

Key Benefits

- Eliminates blower motor noise associated with low fan speeds
- Makes AC-driven blowers as quiet as DC-driven blowers
- User-programmable fan speeds
- Provides overload protection to blower motor
- Easy and economical solution to noisy fans
- Works with all Cruisair and Marine Air cabin controls
- Compatible with blowers up to three amps
- Supports blowers that are 115VAC/60Hz and 208-240VAC/50 or 60Hz
- Support for 115VAC/60Hz blower motors will be available soon
- CE approved

Specifications for WhisperFan Controller

| Model | WhisperFan Control-115V | WhisperFan Control-230V |
|----------------|-------------------------|-------------------------|
| Height (in/mm) | 3.19/82 | 3.19/82 |
| Width (in/mm) | 5.5/140 | 5.5/140 |
| Depth (in/mm) | 6.19/158 | 6.19/158 |

How the WhisperFan Control Works

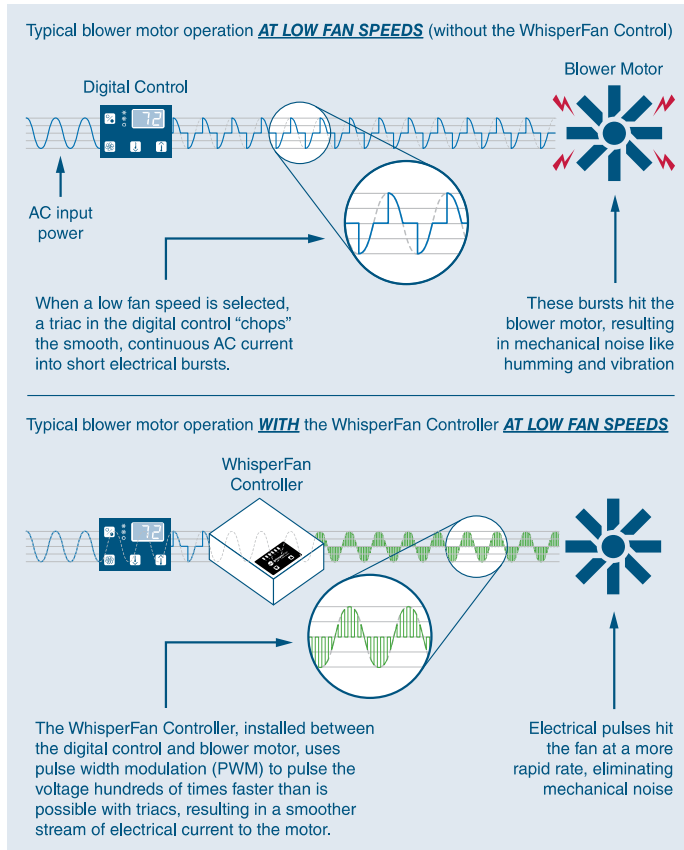

Dimensions

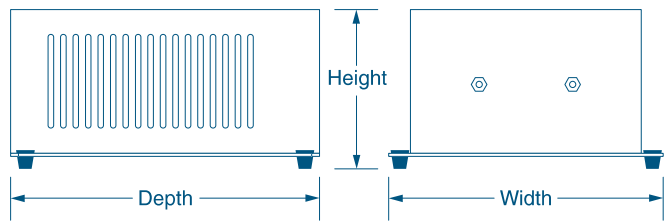

DOMETIC MARINE DIVISION

2000 N. Andrews Ave. Ext. | Pompano Beach, FL 33069 USA | Tel. 954-973-2477 | Fax: 954-979-4414
 www.Dometic.com/Marine | MarineSales@DometicUSA.com

24/7 TECH SUPPORT FOR UNITED STATES & CANADA:

8:00 AM to 5:00 PM Eastern Time: 800-542-2477
 After hours and weekends: 888-440-4494

INTERNATIONAL SALES & SERVICES

Europe & the Middle East: Call +44(0)870-330-6101
 For all other areas visit our website to find your nearest distributor.

Dealer

Marine Centrifugal Seawater Pumps

Ultra-Durable Centrifugal Seawater Pumps



Clockwise from left: Air-cooled AC-5CP-MD and liquid-cooled LC-5CP-MD, LC-3CP-MD, and LC-2CP-MD

Dometic's marine centrifugal seawater pumps are an excellent choice for providing seawater circulation for marine air conditioning systems. The proven magnetic drive eliminates the troublesome mechanical shaft seal.

There is no seal wear, power-robbing friction, or leakage through the seal. The impeller and drive magnets are strong, permanent ceramic types, which prevent slippage, ensuring that full motor power is converted into pumping power.

Centrifugal pumps require a flooded inlet and should be mounted below the waterline. "LC" models have liquid-cooled motors and can be run in open air or submerged. "AC" models have air-cooled, open drip-proof motors and must be in a dry environment.

Replacement parts are available through Dometic.



Liquid-cooled models (clockwise from top): LC-5CP-MD, LC-3CP-MD, and LC-2CP-MD



Air-cooled model AC-5CP-MD

Key Benefits

- Magnetic-drive impeller means no seal to wear, leak, or repair
- Efficient motor with low power consumption
- Exclusive marine-grade base
- 115V and 230V models
- Liquid-cooled (submersible) and air-cooled motors available
- All components in contact with water are plastic, ceramic, or stainless steel
- 6 ft. (1.8 m) power cord is standard
- 1-year warranty on parts

Specifications for Marine Centrifugal Seawater Pumps

| Model | LC-2CP-MD | | LC-3CP-MD | | | LC-5CP-MD | | AC-5C-MD | |
|---------------------------|-------------|------|-------------|-----|-----|-----------|-----|-------------|-----|
| Voltage (V) | 115 | 230 | 115 | 230 | 220 | 115 | 230 | 115 | 230 |
| Cycle ⁽¹⁾ | 50 Hz/60 Hz | | 50 Hz/60 Hz | | | 50 Hz | | 50 Hz/60 Hz | |
| Phase (Ph) | 1 | | 1 | | | 1 | | 1 | |
| Amps (A) | 1 | 0.53 | 2 | 1 | 0.8 | 2.2 | 1.1 | 2.1 | 1 |
| Max. Flow (gpm) | 5 | | 8.5 | | | 14.5 | | 17 | |
| Max. Head (ft/m) | 13/3.1 | | 19/5.8 | | | 27/8.3 | | 27/8.3 | |
| Ignition Protection | yes | | yes | | | yes | | no | |
| Motor HP (hp) | 1/35 | | 1/20 | | | 1/8 | | 1/8 | |
| Motor Type ⁽¹⁾ | TE/SUB | | TE/SUB | | | TE/SUB | | OD | |
| Inlet Connection (in) | 3/4 | | 3/4 | | | 1 | | 1 | |
| Outlet Connection (in) | 1/4 | | 1/2 | | | 1/2 | | 1/2 | |
| Net Weight (lbs/kg) | 5/2.3 | | 9/4.1 | | | 15.5/7.1 | | 10/4.6 | |
| Wet End Assembly | A-507P | | A-508P | | | A-506LC | | A-506 | |

¹ TE/SUB motors are totally enclosed liquid-cooled types and can be operated in the open air or submerged; OD motors are open, drip-proof and air-cooled types which must be kept dry.

Performance Curve

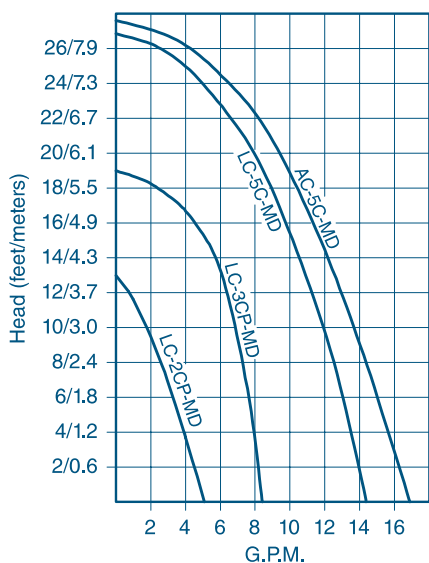

DOMETIC MARINE DIVISION
 2000 N. Andrews Ave. Ext. | Pompano Beach, FL 33069 USA | Tel. 954-973-2477 | Fax: 954-979-4414
 www.Dometic.com/Marine | MarineSales@DometicUSA.com

24/7 TECH SUPPORT FOR UNITED STATES & CANADA:
 8:00 AM to 5:00 PM Eastern Time: 800-542-2477
 After hours and weekends: 888-440-4494

INTERNATIONAL SALES & SERVICES
 Europe & the Middle East: Call +44(0)870-330-6101
 For all other areas visit our website to find your nearest distributor.



Heavy-Duty Seawater Pumps

Centrifugal Pumps for Submersible Or Self-Priming Applications



Left to right: PH3000BX-SP and CPOD120BX pumps shown

Cruisair specifies reliable, heavy-duty centrifugal pumps to provide a steady flow of cooling water through the air conditioning system.

The glass reinforced polypropylene head pumps have magnetic drive impellers, and are available with submersible or air cooled motors. Larger pumps have bronze heads with mechanical seals, and air cooled, drip-proof motors. A wide range of pumps and motors are available for use in different power environments.

Centrifugal pumps must be mounted below the water line. Self-priming pumps are also available for above water line applications. A scoop type through-hull and a seawater strainer are recommended for proper operation.

When more than one air conditioning unit is served by a single pump, a separate pump relay is used. To complete the installation, Cruisair can also supply water manifolds, hose, and fittings.

Key Benefits

- High-capacity centrifugal pumps
- 250 to 10,800 GPH capacities
- 115V and 230V/60Hz, 240V/50Hz, and 220/440V 3-phase models
- Seawater-grade construction with glass-filled polypropylene or bronze pump heads
- Water-cooled (submersible) or air-cooled motors
- High-head pressure models available
- Self-priming pumps available
- Meet or exceed applicable ABYC and US Coast Guard regulations, CE directives, and general Air Conditioning and Refrigeration (ARI) standards

Specifications for Heavy-Duty Seawater Pumps

| Model ⁽¹⁾ | Voltage (V) | Cycle ⁽²⁾ | Phase (Ph) | Amps (A) | Water Flow (gpm/ lpm) | Feet of Head (ft/m) | Inlet Connection (in) | Outlet Connection (in) | Height (in/mm) | Width (in/mm) | Depth (in/mm) |
|----------------------|-------------|----------------------|------------|----------|--------------------------|---------------------|-----------------------|------------------------|----------------|---------------|---------------|
| PML250 | 115 | 60 Hz | 1 | 1 | 3/11.4 | 7/2.2 | ¾ | ¼ | 4.7/120 | 5.6/143 | 6.2/158 |
| PML250C | 230 | 50 Hz/60 Hz | 1 | 0.5 | 3/11.4 | 7/2.2 | ¾ | ¼ | 4.7/120 | 5.6/143 | 6.2/158 |
| PML500 | 115 | 60 Hz | 1 | 2.5 | 6/22.8 | 14/4.3 | ¾ | ½ | 5.6/143 | 5.6/143 | 7.4/188 |
| PML500C | 230 | 50 Hz/60 Hz | 1 | 1 | 6/22.8 | 14/4.3 | ¾ | ½ | 5.6/143 | 5.6/143 | 7.4/188 |
| PML500CK | 230 | 50 Hz | 1 | 1 | 6/22.8 | 9.5/2.9 | ¾ | ½ | 5.6/143 | 5.6/143 | 7.4/188 |
| PMA500 | 115 | 60 Hz | 1 | 2.1 | 7.5/28.4 | 14/4.3 | ¾ | ¾ | 5/127 | 4/102 | 9/229 |
| PMA500C | 230 | 50 Hz/60 Hz | 1 | 1 | 7.5/28.4 | 14/4.3 | ¾ | ¾ | 5/127 | 4/102 | 9/229 |
| PMA500CK | 230 | 50 Hz | 1 | 0.9 | 5/18.1 | 11/3.4 | ¾ | ¾ | 5/127 | 4/102 | 9/229 |
| PMA1000 | 115 | 60 Hz | 1 | 2.2 | 12/45.5 | 14/4.3 | ¾ | ¾ | 6.25/159 | 4.5/115 | 9.1/232 |
| PMA1000C | 230 | 50 Hz/60 Hz | 1 | 1.2 | 12/45.5 | 14/4.3 | ¾ | ¾ | 6.5/159 | 4.5/115 | 9.1/232 |
| P1200BXT | 115 | 50 Hz/60 Hz | 1 | 10.4 | 20/75.8 | 5/1.6 | 1 | 1 | 6.6/168 | 6.5/166 | 13.6/346 |
| P1200BXT-SP | 115 | 50 Hz/60 Hz | 1 | 10.4 | 20/75.8 | 5/1.6 | 1 | 1 | 6.6/168 | 6.5/166 | 13.6/346 |
| P1500BXT | 115 | 50 Hz/60 Hz | 1 | 10.4 | 22/83.3 | 5/1.6 | ¾ | ¾ | 6.6/168 | 6.5/166 | 13.6/346 |
| PS1500BX | 115 | 50 Hz/60 Hz | 1 | 7 | 25/94.7 | 7/2.2 | 1¼ | 1 | 8.1/206 | 6.5/166 | 13/331 |
| PS1500B3X | 230 | 50 Hz/60 Hz | 3 | 3.4 | 25/94.7 | 15/4.6 | 1¼ | 1 | 8.1/206 | 6.5/166 | 15.4/392 |
| PS1800BX | 115 | 50 Hz/60 Hz | 1 | 7 | 30/113.6 | 15/4.6 | 1¼ | 1 | 8.1/206 | 6.5/166 | 13/331 |
| PS2200BX | 115 | 50 Hz/60 Hz | 1 | 7.2 | 37/140.1 | 15/4.6 | 1¼ | 1 | 8.1/206 | 6.5/166 | 13/331 |
| PH3000BXT | 115 | 50 Hz/60 Hz | 1 | 10.6 | 50/189.3 | 7/2.2 | 1¼ | 1 | 6.6/168 | 6.5/166 | 14.2/361 |
| PH3000BX-SP | 115 | 50 Hz/60 Hz | 1 | 13.8 | 50/189.3 | 30/9.2 | 1¼ | 1 | 9.8/249 | 8.5/216 | 18.7/475 |
| PH3000BXT | 115 | 50 Hz/60 Hz | 1 | 3.4 | 50/189.3 | 20/6.1 | 1¼ | 1 | 6.6/168 | 6.5/166 | 14.2/361 |
| PH3000B3X | 230 | 50 Hz/60 Hz | 3 | 2.6 | 50/189.3 | 20/6.1 | 1¼ | 1 | 8.1/206 | 6.5/166 | 15.4/392 |
| PH3000BX-SP | 115 | 50 Hz/60 Hz | 1 | 13.8 | 50/189.3 | 30/9.2 | 1¼ | 1 | 9.8/249 | 8.5/216 | 18.7/475 |
| PH3000BX | 230 | 50 Hz/60 Hz | 1 | 6 | 50/189.3 | 20/6.1 | 1¼ | 1 | 9/229 | 9.75/248 | 14.5/369 |
| PH3000B3X-SP | 230 | 50 Hz/60 Hz | 3 | 3.4 | 50/189.3 | 20/6.1 | 1¼ | 1½ | 9.8/249 | 8.5/216 | 18.7/475 |
| P3600BX | 115 | 50 Hz/60 Hz | 1 | 11.2 | 70/264.1 | 20/6.1 | 1½ | 1½ | 9.4/239 | 6.5/166 | 14.5/369 |
| P3600B3X | 230 | 50 Hz/60 Hz | 3 | 2.8 | 70/264.1 | 20/6.1 | 1½ | 1½ | 9.4/239 | 6.5/166 | 14.5/369 |
| PH4000BX | 115 | 50 Hz/60 Hz | 1 | 14.2 | 70/264.1 | 30/9.2 | 1½ | 1½ | 9.4/239 | 6.5/166 | 15.8/402 |
| PH4000B3X | 230 | 50 Hz/60 Hz | 3 | 3.8 | 70/264.1 | 30/9.2 | 1½ | 1½ | 9.4/239 | 6.5/166 | 15.8/402 |
| P4800BX-SP | 230 | 50 Hz/60 Hz | 1 | 6.4 | 70/264.1 | 28/8.6 | 1½ | 1½ | 11.5/293 | 8.5/216 | 21.5/547 |
| PH5400B3X | 230 | 50 Hz/60 Hz | 3 | 5 | 90/340.7 | 45/13.8 | 2 | 2 | 9.75/248 | 8.5/216 | 16/407 |
| P7800BX | 115 | 50 Hz/60 Hz | 1 | 15 | 130/492.2 | 18/5.5 | 2½ | 2½ | 10/254 | 8.5/216 | 17.6/448 |
| P7800B3X | 230 | 50 Hz/60 Hz | 3 | 3.4 | 130/492.2 | 18/5.5 | 2½ | 2½ | 10/254 | 8.5/216 | 17.6/448 |
| P10500B3X | 380 | 50 Hz | 3 | 5.4 | 175/662.5 | 20/6.1 | 2½ | 2½ | 10/254 | 8.5/216 | 18/458 |
| P10800BX | 115 | 50 Hz/60 Hz | 1 | 14.2 | 180/681.4 | 20/6.1 | 2½ | 2½ | 10/254 | 8.5/216 | 18/458 |
| P10800B3X | 230 | 50 Hz/60 Hz | 1 | 5.2 | 180/681.4 | 20/6.1 | 2½ | 2½ | 10/254 | 8.5/216 | 18/458 |

¹ For information about pumps larger than P711, please call the applications department at 954-973-2477.
² 50/60Hz pumps may be operated at 50Hz and reduced voltages but with a 17% reduction in flow and as much as a 30% drop in head; 60Hz only pumps may not be operated at 50Hz.

DOMETIC MARINE DIVISION
 2000 N. Andrews Ave. Ext. | Pompano Beach, FL 33069 USA | Tel. 954-973-2477 | Fax: 954-979-4414
 www.Domestic.com/Marine | MarineSales@DomesticUSA.com

24/7 TECH SUPPORT FOR UNITED STATES & CANADA:
 8:00 AM to 5:00 PM Eastern Time: 800-542-2477
 After hours and weekends: 888-440-4494

INTERNATIONAL SALES & SERVICES
 Europe & the Middle East: Call +44(0)870-330-6101
 For all other areas visit our website to find your nearest distributor.

L-0242 Rev. 20131122

Specifications and availability subject to change without notice.

Dealer



Centrifugal Circulating Water Pumps

For Use In Tempered Water Air Conditioning Systems



Left to right: PH3000BX-SP and CPOD120BX pumps shown

Cruisair specifies reliable, heavy-duty water pumps for use in circulated water air conditioning systems. All pumps are centrifugal, with bronze and stainless components.

Pumps are available with 115/230V single-phase, or 230/460 3-phase, dual voltage motors. Most are rated for 50/60 Hz use, but special 50 Hz only pumps are also available for full performance.

Circulation pumps are sized for the total loop capacity. Cruisair design specification is 3 gpm (11.4 lpm) per 12,000 Btu/hr capacity, rated at 40' (12.2 meters) head. Seawater pumps are selected for the tempering unit capacity, at 250 gph (15.8 lpm) per 12,000 Btu/hr.

Self-priming seawater pumps are available for installations where the pump cannot be mounted below the water line, or if air is able to enter the system such as on a sailboat or high speed craft.

Pump relays are used to control each pump. The circulation pump must run whenever the system is cooling or heating, and the seawater pump is typically cycled with the tempering units.

Single-phase pumps have internal overload protection. An external overload relay should be used with 3-phase pumps.

Key Benefits

- High-capacity centrifugal pumps
- Seawater-grade construction with glass-filled polypropylene or bronze pump heads
- Single-phase 115/230V or three-phase 230/460V dual voltage
- 50 or 60Hz models
- Rated at 40 ft. (12.2 m) of head
- Meet or exceed applicable ABYC and US Coast Guard regulations, CE directives, and general Air Conditioning and Refrigeration (ARI) standards

Specifications for Centrifugal Circulating Water Pumps

| Model ⁽¹⁾ | CP0D80BX | CP0D120BX | CP0D120B3X | CP0D120B3K | CP0D180BX | CP0D180B3K | CP0D180B3K | CP0D180B3K | CP0D240BX | CP0D240B3K | CP0D240B3K | CP0D360B3K | CP0D500BX | CP0D500B3K | CP0D500B3K | CP0D800B3X |
|---|----------|-----------|------------|------------|-----------|------------|------------|------------|-----------|------------|------------|------------|-----------|------------|------------|------------|
| Capacity (BTU/h) ⁽²⁾ | 80000 | 120000 | 120000 | 120000 | 180000 | 180000 | 180000 | 180000 | 240000 | 240000 | 240000 | 360000 | 500000 | 500000 | 500000 | 800000 |
| Voltage (V) | 115 | 115 | 380 | 380 | 115 | 380 | 380 | 380 | 115 | 380 | 380 | 230 | 115 | 230 | 115 | 230 |
| Cycle 1 (Hz) | 50 | 50 | 50 | 50 | 50 | 50 | 50 | 50 | 50 | 50 | 50 | 50 | 50 | 60 | 50 | 50 |
| Cycle 2 (Hz) | 60 | N/A | 60 | N/A | 60 | N/A | N/A | N/A | 60 | N/A | N/A | N/A | 60 | 60 | 60 | 60 |
| Phase (Ph) | 1 | 3 | 3 | 3 | 1 | 3 | 3 | 3 | 1 | 3 | 3 | 3 | 1 | 3 | 1 | 3 |
| Amps (A) ⁽³⁾ | 8 | 14 | 2.8 | 5.2 | 14 | 14.2 | 7 | 14.2 | 4 | 2.2 | N/A | 19.2 | 7 | 7 | 9.6 | 9.6 |
| Chilled Water Inlet Connection (in) | 1 1/4 | 1 1/2 | 1 1/2 | 1 1/2 | 1 1/2 | 1 1/2 | 1 1/2 | 1 1/2 | 2 | 2 | 2 | 2 | 2 1/2 | 2 1/2 | 2 1/2 | 2 1/2 |
| Chilled Water Discharge Connection (in) | 1 | 1 1/2 | 1 1/2 | 1 1/2 | 1 1/2 | 1 1/2 | 1 1/2 | 1 1/2 | 1 1/2 | 1 1/2 | 1 1/2 | 1 | 1 | 1 | 1 | 1 |
| Height (in/mm) | 6.5/166 | 9.4/239 | 9.4/239 | 9.4/239 | 9.4/239 | 9.4/239 | 9.4/239 | 9.4/239 | 8.6/219 | 8.6/219 | 8.6/219 | 8.6/219 | 10/254 | 10/254 | 10/254 | 10/254 |
| Width (in/mm) | 6.5/166 | 6.5/166 | 6.5/166 | 6.5/166 | 6.5/166 | 6.5/166 | 6.5/166 | 6.5/166 | 10/254 | 10/254 | 10/254 | 11/280 | 11/280 | 11/280 | 11/280 | 11/280 |
| Depth (in/mm) | 12.8/326 | 14.5/369 | 14.5/369 | 15.6/397 | 15.8/402 | 15.6/397 | 15.6/397 | 15.6/397 | 15.9/404 | 15.9/404 | 15.9/404 | 16.1/409 | 18/458 | 18/458 | 18/458 | 18/458 |

¹ For information about pumps larger than P711, please call the applications department at 954-973-2477.
² Determined using an average of 3 GPM per ton (12,000 BTU/h) of air conditioning at given GPM and head, and are rated for direct expansion (DX) systems only.
³ N/A indicates a dual voltage pump. Please contact Dometic Marine sales at 954-973-2477 for specific amperage based on your voltage requirements.

DOMETIC MARINE DIVISION
 2000 N. Andrews Ave. Ext. | Pompano Beach, FL 33069 USA | Tel. 954-973-2477 | Fax: 954-979-4414
www.Dometic.com/Marine | MarineSales@DometicUSA.com

24/7 TECH SUPPORT FOR UNITED STATES & CANADA:
 8:00 AM to 5:00 PM Eastern Time: 800-542-2477
 After hours and weekends: 888-440-4494

INTERNATIONAL SALES & SERVICES
 Europe & the Middle East: Call +44(0)870-330-6101
 For all other areas visit our website to find your nearest distributor.

L-0420 Rev. 20130104

Specifications and availability subject to change without notice.

Dealer



Pump Relays for DX Air Conditioning

For Coordination of a Single Pump Serving Multiple Condensers



Pump relays are used to control cycling of seawater pumps when more than one condensing unit is supported by a single pump. One control trigger is needed for each condensing unit.

The PR8X is a solid-state relay which supports up to eight systems. Control triggers, matched to the system control voltage, are ordered separately and added at the time of installation. Trigger circuits for both 115V and 230V systems may be installed in the same PR8X box. The PR8X is ignition protected.

The PR3X type relay is ordered with two or three pre-installed control triggers which are matched to the system voltage. The PR3X-2 can be upgraded from two to three triggers in the field. Models can be ordered for 115 or 230V control voltage and can control 115V or 230V pumps. The unit is ignition protected.

The PR4D pump relays handle up to four control triggers which are ordered separately and added at the time of installation. The PR4D is used to control 230V 3-phase pumps.

Key Benefits

- Ignition protected
- Up to eight control triggers
- 115V and 230V models
- 15A fuse on pump circuit

Specifications for Pump Relays for DX Air Conditioning

| Model | PR3X-2 | PR3X-2C | PR3X-3 | PR3X-3C | PR8X | PR8X-4 | PR8X-4C | PR8X-5C | PR8X-6C | PR8X-7C |
|------------------------------------|----------|----------|----------|----------|----------|----------|----------|----------|----------|----------|
| Control Voltage (V) ⁽¹⁾ | 115 | 230 | 115 | 230 | 115 | 115 | 230 | 230 | 230 | 230 |
| Phase (Ph) | 1 | 1 | 1 | 1 | 1 | 1 | 1 | 1 | 1 | 1 |
| Pump Voltage (V) | 115/230 | 115/230 | 115/230 | 115/230 | 115/230 | 115/230 | 115/230 | 115/230 | 115/230 | 115/230 |
| Max. Circuit Breaker (A) | 25 | 25 | 25 | 25 | 25 | 25 | 25 | 25 | 25 | 25 |
| Height (in/mm) | 2.38/61 | 2.38/61 | 2.38/61 | 2.38/61 | 5.25/134 | 5.25/134 | 5.25/134 | 5.25/134 | 5.25/134 | 5.25/134 |
| Width (in/mm) | 7.94/202 | 7.94/202 | 7.94/202 | 7.94/202 | 10.5/267 | 10.5/267 | 10.5/267 | 10.5/267 | 10.5/267 | 10.5/267 |
| Depth (in/mm) | 5.5/140 | 5.5/140 | 5.5/140 | 5.5/140 | 7/178 | 7/178 | 7/178 | 7/178 | 7/178 | 7/178 |
| Gross Weight (lbs/kg) | 4/1.9 | 2/1 | 4/1.9 | 2/1 | 2/1 | 4/1.9 | 4/1.9 | 3/1.4 | 4/1.9 | 4/1.9 |

¹ TR115 and TR230 control triggers are ordered separately depending on the application.

Dimensions

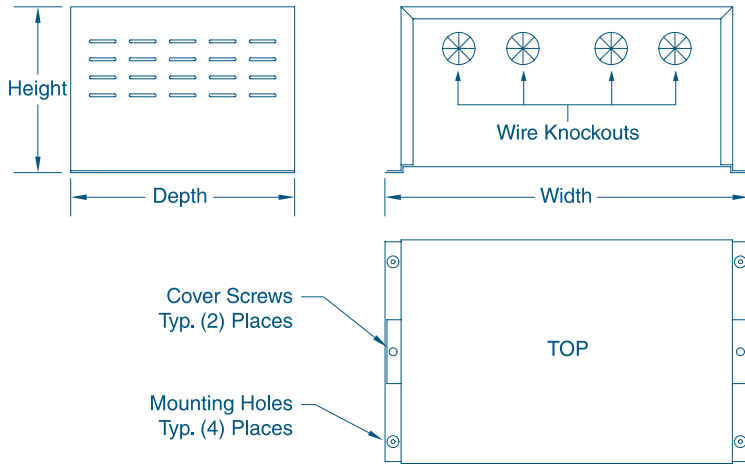

DOMETIC MARINE DIVISION
 2000 N. Andrews Ave. Ext. | Pompano Beach, FL 33069 USA | Tel. 954-973-2477 | Fax: 954-979-4414
 www.Dometic.com/Marine | MarineSales@DometicUSA.com

24/7 TECH SUPPORT FOR UNITED STATES & CANADA:
 8:00 AM to 5:00 PM Eastern Time: 800-542-2477
 After hours and weekends: 888-440-4494

INTERNATIONAL SALES & SERVICES
 Europe & the Middle East: Call +44(0)870-330-6101
 For all other areas visit our website to find your nearest distributor.

L-0373 Rev. 20130517 Specifications and availability subject to change without notice.



Pump Packages for Chilled Water Systems

Convenient Solutions for Simpler Chiller Installations



Pump packages reduce the installation time of chilled water systems by combining several necessary components in one convenient package. The packages include a chilled-water pump, expansion tank, pump drain pan, dual-scale (psi/kPa) pressure gauge, and fill assembly. The fill assembly includes a hose connection, ball valve, and pressure-reducing valve.

The cushion of air in the expansion tank allows the water to expand and contract with temperature fluctuations. This relieves pressure that might otherwise result in leaks.

The latest design includes a bladder-style expansion tank. Without the bladder, air in the expansion tank would gradually dissolve into the water and be bled off. Eventually, the protective cushion of air would be gone.

The pressure gauge is connected to an inlet pipe on the pump for the most accurate reading of system return water pressure.

Key Benefits

- Convenient packaging of multiple essential components simplifies installation
- Expansion tank protects against thermal expansion
- Bladder-style expansion tank protects against loss of air cushion
- Dual-scale pressure gauge is convenient for US and international customers
- Pressure gauge connected to inlet pipe gives most accurate reading

Specifications for Pump Packages for Chilled Water Systems

| Model ⁽¹⁾ | PMA1000 | | | P700 | | P120 | |
|------------------------------------|---------------|-----|-------|----------------|------------|---------------|---------|
| Voltage (V) | 115 | 230 | 240 | 115 | 230 | 115 | 230 |
| Cycle (Hz)/Phase (Ph) | 60/1 | | | 60/1 | | 60/1 | |
| Total Air Handler Capacity (BTU/h) | 16000 - 23000 | | 16000 | 49000 - 120000 | | 24000 - 48000 | |
| Inlet Connection (in) | 1/2" /MPT | | | 1" /FPT | | 1" /FPT | |
| Outlet Connection (in) | 1" /FPT | | | 1 1/4" /FPT | | 1 1/4" /FPT | |
| Height (in/mm) | 9.2/234 | | | 9.5/242 | | 9.2/234 | 9.5/242 |
| Width (in/mm) | 12.9/328 | | | 17.1/435 | | 12.9/328 | |
| Depth-Drain Pan (in/mm) | 18/458 | | | 18/458 | | 18/458 | |
| Max. Depth (in/mm) | 18/458 | | | 18/458 | | 18/458 | |
| Net Weight (lbs/kg) | 33/15 | | | 49/22.3 | 49.25/22.4 | 48/21.8 | |
| Gross Weight (lbs/kg) | 47/21.4 | | | 62/28.2 | 69.5/31.6 | 62/28.2 | |

¹ Pump packages do NOT include a backflow preventer. If the chilled water fill assembly is fed by a potable water supply, then a reduced pressure zone (RPZ) backflow preventer should be installed between the fill assembly and the supply to prevent contamination of the potable water.

Dimensions

PMA1000

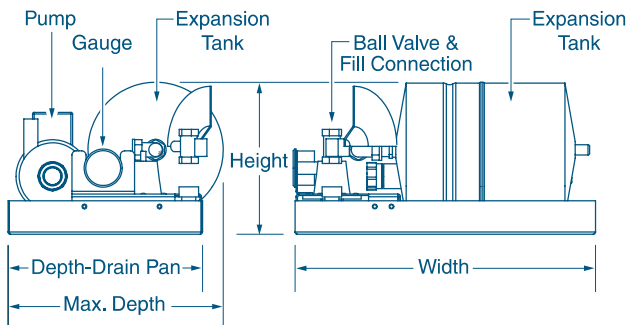

P120/P700

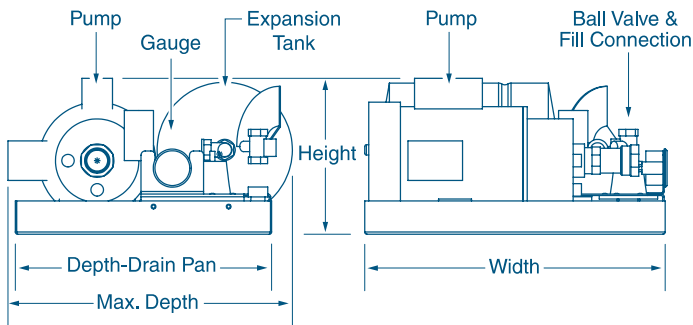

Safety Notice:

Pump packages do NOT include backflow preventers. If the chilled water fill assembly is supplied by a potable water supply, then a reduced pressure zone (RPZ) backflow preventer should be installed between the fill assembly and the potable water supply to prevent contamination of the water.

DOMETIC MARINE DIVISION

2000 N. Andrews Ave. Ext. | Pompano Beach, FL 33069 USA | Tel. 954-973-2477 | Fax: 954-979-4414
 www.Dometic.com/Marine | MarineSales@DometicUSA.com

24/7 TECH SUPPORT FOR UNITED STATES & CANADA:

8:00 AM to 5:00 PM Eastern Time: 800-542-2477
 After hours and weekends: 888-440-4494

INTERNATIONAL SALES & SERVICES

Europe & the Middle East: Call +44(0)870-330-6101
 For all other areas visit our website to find your nearest distributor.



Variable Frequency Drives (Standard)

Smooths Out Chilled Water Compressor Startup Power Demand



A Variable Frequency Drive (VFD) completely eliminates the large starting inrush current of the compressor by ramping up voltage and frequency in a controlled time period. This allows running on limited dockside power, and also protects the generator from overload.

In addition to eliminating inrush, the VFD will also run a 60Hz rated compressor at 60Hz even when input power is 50Hz, which allows full BTU capacity performance (230V only). The drive also protects the compressor by monitoring input voltage and output current, and will shut down if a problem is detected. On 208/230V systems, the VFD can “convert” single-phase input power to 3-phase output; however, the VFD current capacity must be derated (see table on second page).

The VFD unit produces a modified sine wave output for smooth acceleration and running, with precise frequency resolution. It is designed to operate in extreme environments, such as an engine room. However, the enclosure is ventilated, and must be kept dry. Any direct water contact can damage the unit.

Built-in noise filters are standard and the VFD is CE approved. The Schneider Electric Altivar 312 VFDs incorporate a class A EMC filter into their design. This helps prevent high frequency noise from affecting the AC power supply to which the drives are connected. If you have an application or a power system that requires even lower noise emission, then we recommend you purchase the class B EMC filters specifically designed to fit with the entire family of Altivar 312 VFDs. To reduce the harmonic distortion caused by the VFD, we recommend you purchase a line reactor sized appropriately for the particular VFD.

An LED display allows the user to monitor operation and faults. The VFD is pre-programmed from the factory and no further setup is required. Power cables are available through special order.

How to choose the right size Variable Frequency Drive:

- Chiller compressor must be 3 phase and each compressor requires a dedicated VFD.
- Multiply the chiller’s reverse cycle amps by 1.10 (10% safety factor).
- Choose the VFD from the Comp Voltage and Max AMP Rating columns (in the table on the following page) depending on compressor voltage and the phase of the input power supply, respectively.

Key Benefits

- Eliminates compressor start-up in-rush current
- 208/230V three-phase output with one- or three-phase input
- Full 60Hz capacity even at 50Hz input (230V only)
- Low electronic noise
- CE approved
- 380/460V three-phase models available

Specifications for Variable Frequency Drives (Standard)

| Model ⁽¹⁾ | VFD SQD17.5A 230V | VFD SQD27.5A 230V | VFD SQD33A 230V | VFD SQD54A 230V | VFD SQD66A 230V | VFD SQD9.5A 460V | VFD SQD14.3A 460V | VFD SQD17A 460V | VFD SQD27.7A 460V | VFD SQD33A 460V |
|---------------------------------------|----------------------|----------------------|--------------------|--------------------|--------------------|---------------------|----------------------|--------------------|----------------------|--------------------|
| Reference Number | 4251104 | 4251105 | 4251106 | 4251110 | 4251111 | 4251108 | 4251112 | 4251202 | 4251109 | 4251201 |
| Compressor Voltage (V) ⁽²⁾ | 208/230 | 208/230 | 208/230 | 208/230 | 208/230 | 380/460 | 380/460 | 380/460 | 380/460 | 380/460 |
| Max. Amps @ 3-PH. Input (A) | 17.5 | 27.5 | 33 | 54 | 66 | 9.5 | 14.3 | 17 | 27.7 | 33 |
| Max. Amps @ 1-PH. Input (A) | 10.1 | 15.9 | 19.1 | 31.2 | 38.1 | N/A | N/A | N/A | N/A | N/A |
| Height (in/mm) | 7.2/183 | 9.1/232 | 9.1/232 | 13/331 | 13/331 | 7.2/183 | 9.1/232 | 9.1/232 | 13/331 | 13/331 |
| Width (in/mm) | 5.5/140 | 7.1/181 | 7.1/181 | 9.7/247 | 9.7/247 | 5.5/140 | 7.1/181 | 7.1/181 | 9.7/247 | 9.7/247 |
| Depth (in/mm) | 5.9/150 | 6.7/171 | 6.7/171 | 7.5/191 | 7.5/191 | 5.9/150 | 6.7/171 | 6.7/171 | 7.5/191 | 7.5/191 |

¹ For programmed VFDs, please call your sales representative with the reference number and programming information (output voltage, input phase, and output frequency).
² 208-230V models will perform at 60Hz output even with 50Hz input, allowing 60Hz compressors to perform at full capacity in 50Hz systems. High-voltage 380-480V models can be used at 380-420V 50Hz or 440-480V 60Hz, and output frequency should match the input.

Dimensions

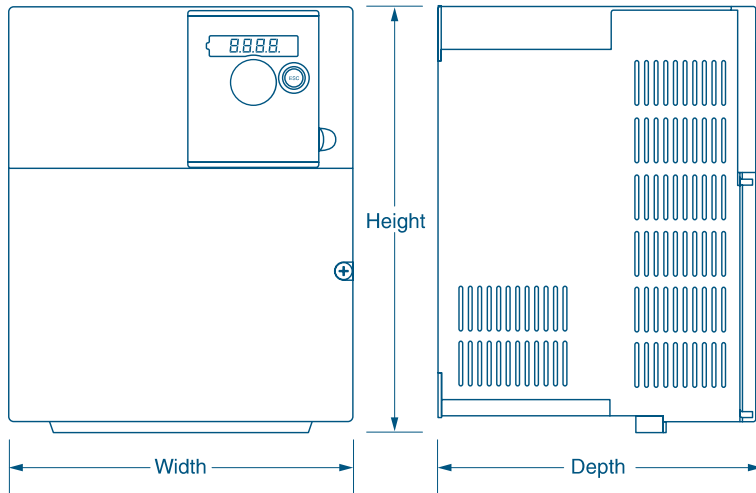

DOMETIC MARINE DIVISION
 2000 N. Andrews Ave. Ext. | Pompano Beach, FL 33069 USA | Tel. 954-973-2477 | Fax: 954-979-4414
 www.Dometic.com/Marine | MarineSales@DometicUSA.com

24/7 TECH SUPPORT FOR UNITED STATES & CANADA:
 8:00 AM to 5:00 PM Eastern Time: 800-542-2477
 After hours and weekends: 888-440-4494

INTERNATIONAL SALES & SERVICES
 Europe & the Middle East: Call +44(0)870-330-6101
 For all other areas visit our website to find your nearest distributor.

L-2413 Rev. 20130920 Specifications and availability subject to change without notice.



HMDL Series Auxiliary Heat Modules

Providing Additional Ductable Heating In Cold Conditions



Cruisair auxiliary heat modules provide additional heating when the boat is in extremely cold seawater. They also permit specific compartments on the boat to be heated when the circulated water system is in the cooling mode.

The modules are installed on the discharge side of the air handler. Safety features include: fin tube heating elements with relatively low surface temperature, high temperature insulation on interior of unit, and two-stage thermal protection.

Air handling units are available with integral electrical heat (CHBB Type).

Key Benefits

- Electric resistance heat modules
- Up to 4 kW electric heat
- 115V and 230V operation
- Fin tube heating elements
- Two-stage thermal protection
- High-temperature thermal protection
- Installed in flexible or built-in duct
- Used with ducted air handlers

Specifications for HMDL Series Auxiliary Heat Modules

| Model ⁽¹⁾ | HMDL1-5 | HMDL1C-5 | HMDL1.5-6 | HMDL1.5C-6 | HMDL1.5-7 | HMDL1.5C-7 | HMDL2-7 | HMDL2C-7 | HMDL3C-8 | HMDL4DC-9 |
|----------------------------------|----------|----------|-----------|------------|-----------|------------|----------|----------|----------|-----------|
| Voltage (V) | 115 | 230 | 115 | 230 | 115 | 230 | 115 | 230 | 230 | 230 |
| Cycle (Hz)/Phase (Ph) | 60/1 | 60/1 | 60/1 | 60/1 | 60/1 | 60/1 | 60/1 | 60/1 | 60/1 | 60/3 |
| Heater Amps (A) | 8.7 | 4.4 | 13 | 6.5 | 13 | 6.5 | 17.4 | 8.7 | 13 | 10 |
| Max. Circuit Breaker (A) | 15 | 10 | 25 | 10 | 25 | 10 | 35 | 15 | 25 | 20 |
| Min. Circuit Ampacity (A) | 11 | 6 | 17 | 9 | 17 | 9 | 22 | 11 | 17 | 13 |
| Height (in/mm) ⁽²⁾⁽³⁾ | 7/178 | 7/178 | 7.8/199 | 7.8/199 | 7.8/199 | 7.8/199 | 7.8/199 | 7.8/199 | 9.6/244 | 9.6/244 |
| Width (in/mm) ⁽³⁾ | 11.9/303 | 11.9/303 | 13.3/338 | 13.3/338 | 13.4/341 | 13.4/341 | 13.4/341 | 13.4/341 | 15.5/394 | 15.5/394 |
| Depth (in/mm) ⁽³⁾ | 9.9/252 | 9.9/252 | 10.1/257 | 10.1/257 | 9.9/252 | 9.9/252 | 9.9/252 | 9.9/252 | 11.9/303 | 12/305 |
| Fits Duct Size (in/mm) | 5/127 | 5/127 | 6/153 | 6/153 | 7/178 | 7/178 | 7/178 | 7/178 | 8/204 | 9/229 |
| Gross Weight (lbs) | 10.5 | 10.5 | 10.5 | 10.5 | 10.5 | 10.5 | 10.5 | 10.5 | 14 | 13 |

¹ Interpreting HMDL model numbers: 'HM' = Heat Module; 'D' = Ducted; '1' to '4' = kW of electric heat; 'C' = 230V; No 'C' = 115V; 'DC' = 230V 3-phase; '-5' to '-8' = Duct size in inches.
² Height does not include mounting grommets.
³ All dimensions ± 0.25 in. (6 mm).

Dimensions

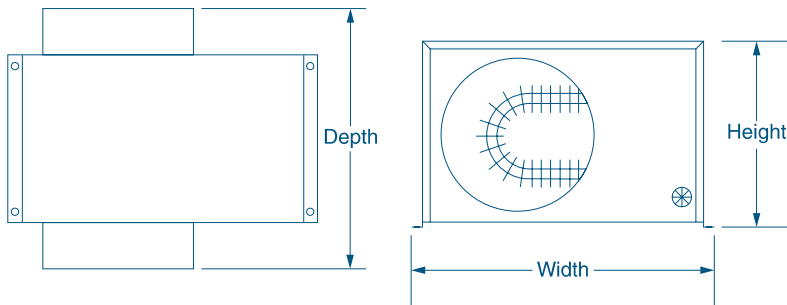

DOMETIC MARINE DIVISION
 2000 N. Andrews Ave. Ext. | Pompano Beach, FL 33069 USA | Tel. 954-973-2477 | Fax: 954-979-4414
 www.Dometic.com/Marine | MarineSales@DometicUSA.com

24/7 TECH SUPPORT FOR UNITED STATES & CANADA:
 8:00 AM to 5:00 PM Eastern Time: 800-542-2477
 After hours and weekends: 888-440-4494

INTERNATIONAL SALES & SERVICES
 Europe & the Middle East: Call +44(0)870-330-6101
 For all other areas visit our website to find your nearest distributor.

L-0622 Rev. 20130419 Specifications and availability subject to change without notice.



Air Distribution Components

Grilles, Duct, & Transition Boxes to Complete the A/C System



Supply and return air grilles are available in several wood types, painted aluminum and plastic, and come in a wide range of sizes and configurations

Marine Air and Cruisair offer supply and return air grilles in a wide assortment of dimensions, styles, and materials to complement any yacht's interior. Custom sizes, materials, and colors are available.

The louvres of supply air grilles are secured by nylon bushings for easy and dependable positioning. Return air grilles have fixed louvres. Wood return air grilles have a lint screen which can be removed for cleaning.

Round plastic supply air grilles are offered in several colors and are available with and without shut-off dampers.

Marine Air and Cruisair also offer additional air distribution components, such as duct and transition boxes, to complete the boat air conditioning system. There are two types of duct available: round/wire with woven fabric and round/wire and mylar fabric shell with 1.0 in. (25 mm) thick insulation. A full range of diameters and lengths are available, and all duct attaches easily to duct rings, grilles, and transition boxes.

Transition boxes come in two styles: Fully-insulated aluminum construction and vacuum-formed ABS plastic. Aluminum boxes come in standard and custom sizes and are ideal for applications where space is limited. ABS boxes are off the shell and feature insulated mounting pads and a unique stepped-ring design for flexibility.



Flexible duct is available in a wide range of diameters and lengths.



Vacuum-formed ABS transition boxes have insulated mounting pads and a stepped duct ring design.



Aluminum transition boxes are available in standard and custom sizes and configurations.

Key Benefits

- Supply and return air grilles available in aluminum, plastic, and wood construction in a wide range of sizes and configurations
- Grilles are available in custom finishes, colors, and sizes
- Wood return air grilles have pop-out louvres and easy-to-clean filters
- Wood return air grilles have pop-out louvres and easy-to-clean filters
- Wood supply air grilles have double-deflection, moveable louvres available in anodized bronze or aluminum finish
- Aluminum return air grilles have durable fixed-vane louvres and are available with or without filters
- Aluminum supply air grilles have adjustable louvres to direct air flow
- Durable polyurethane paint finishes available with aluminum grilles
- Transition boxes available in aluminum or vacuum-formed ABS plastic construction and do not restrict airflow
- Aluminum t-boxes are full insulated and ideal for applications where space is limited; standard and custom sizes
- ABS t-boxes have insulated mounting pads and a unique stepped ring design for flexibility

Grille Sizing by Air Handler BTU/hr Capacity

| Capacity (BTU/hr) | Return Air Grille Size (sq. in./sq. cm) | Supply Air Grille Size (sq. in./sq. cm) | Duct Ring Diameter (in./mm) |
|-------------------|---|---|-----------------------------|
| 4000 | 64/413 | 32/206.5 | 4/102 |
| 6000 | 70/451.6 | 35/225.8 | 4/102 |
| 9000 | 98/632.3 | 49/316 | 6/152 |
| 10000 | 100/645.2 | 60/387 | 6/152 |
| 12000 | 130/838.8 | 70/451.6 | 6/152 |
| 18000 | 200/1290.4 | 100/645.2 | 7/178 |
| 24000 | 240/1548.5 | 140/903.3 | 9/229 |
| 36000 | 360/2322.7 | 196/1264.6 | 10/254 |

Return and Supply Air Grilles

Wood Grilles

- Cut-out dimensions are equal to the grille's nominal height and width.
- Outside frame dimensions are 0.9375 in. (± 0.0625) (24 mm (± 2 mm)) larger than nominal grille size.
- Grille depth, as measured from back of frame: Primary supply air grilles (VH models) are 1.375 in. (35 mm), secondary closeable supply air grilles (VML models) are 1.875 in. (48 mm), and return air grilles (RA models) are 0.875 in. (22 mm).
- Frame (flange) dimensions are 0.563 (14 mm) on all sides.

Aluminum Grilles

- Cut-out dimensions for supply air grilles (TH and TV models) and return air grilles without filter (TRA) are 0.375 in. (10 mm) smaller than nominal grille size. Cut-out dimensions for return air grilles with filter (TRAF models) are 0.125 in. (3 mm) smaller.
- Outside frame dimensions for all aluminum grilles are 0.875 in. (22 mm) larger than nominal grille size.
- Grille depth, as measured from back of frame: Supply air grilles are 0.875 in. (22 mm) and return air grilles are 1.0 in. (25 mm).
- Frame (flange) dimensions are 0.625 in. (16 mm) on all sides.

Plastic Grilles (Circular)

- Cut-out dimensions are 2.0 in. (51 mm) for 2SA models (2 in. duct), 3.0 in. (76 mm) for 3SA models (3 in. duct), and 4.0 in. (102 mm) for 4SA models (4 in. duct).
- Grille depth, as measured from back of frame: 2SA models are 1.31 in. (33 mm), 3SA models are 2.16 in. (55 mm), and 4SA models are 2.38 in. (60 mm).
- Frame (flange) diameter is 2.75 in. (70 mm) for 2SA models, 3.875 in. (98 mm) for 3SA models, and 5.50 in. (140 mm) for 4SA models. A special adapter is available to use with the 4SA for 3.0 in. (76 mm) duct.

Transitions

Vacuum-Formed Transitions

- Opening dimensions are 0.375 in. (10 mm) larger than the transition size.
- Flange-to-flange dimensions are 1.5 in. (38 mm) larger than the transition size.
- Depth, as measured from back of flange: 4.0 in. (102 mm) for 4x models, 4.5 (114 mm) or 5.75 in. (146 mm) for 5x and 6x models with round or obround duct rings, respectively.
- Flange dimensions are 0.5625 (143 mm) on all sides.

Square Vacuum-Formed Transitions

- Available in 5.25 in. (134 mm) and 6.25 in. (159 mm) square.
- Opening dimensions are 0.5 in. (13 mm) larger than the transition size.
- Flange-to-flange dimensions are 1.75 in. (44 mm) larger than the transition size.
- Depth is 0.125 in. (3 mm) more than the transition size.
- Flange dimensions are 0.625 in. (16 mm) on all sides.

Vacuum-Formed Transition Boxes

- Height, with mounting flange, for 10,000, 12,000, and 16,000 t-boxes is 7.875 in. (200 mm); 7,000 t-box is 6.875 in. (175 mm).
- The 10,000, 12,000, and 16,000 t-boxes accommodate 6 in. (153 mm), 5 in. (127 mm), and 4 in. (102 mm) duct rings on one side and 5 in., 4 in. and 3 in. (76 mm) duct rings on the other side.
- The 7,000 t-box accommodates 5 in. (127 mm) and 4 in. (102 mm) duct rings on one side and 4 in. and 3 in. (76 mm) duct rings on the other side.

Aluminum Transitions

- Opening dimensions are 0.25 in. (7 mm) larger than the transition size.
- Flange-to-flange dimensions are 1.75 in. (44 mm) larger than the transition size.
- Depth of aluminum transitions is 0.25 in. (7 mm) more than the diameter of the largest round ring, as measured from the back of the flange.
- Flange dimensions are 0.75 in. (19 mm) on all sides.

Obround (OB) Ring Dimensions

- 3 in. ABS (76 mm) OB = 3.875 x 1.625 in. (95 x 42 mm), 2 in. (51 mm) depth
- 4 in. ABS (102 mm) OB = 5.125 x 2.25 in. (130 x 58 mm), 2 in. (51 mm) depth
- 5 in. ABS (127 mm) OB = 6.5 x 2.625 in. (165 x 67 mm), 2 in. (51 mm) depth
- 6 in. ABS (153 mm) OB = 7.438 x 3.375 in. (189 x 86 mm), 2 in. (51 mm) depth
- 7 in. ABS (178 mm) OB = 9.0 x 3.625 in. (223 x 92 mm), 2 in. (51 mm) depth
- 8 in. aluminum (204 mm) OB = 9.25 x 5.0 in. (235 x 127 mm), 2 in. (51 mm) depth

DOMETIC MARINE DIVISION

2000 N. Andrews Ave. Ext. | Pompano Beach, FL 33069 USA | Tel. 954-973-2477 | Fax: 954-979-4414
www.Dometic.com/Marine | MarineSales@DometicUSA.com

24/7 TECH SUPPORT FOR UNITED STATES & CANADA:

8:00 AM to 5:00 PM Eastern Time: 800-542-2477
After hours and weekends: 888-440-4494

INTERNATIONAL SALES & SERVICES

Europe & the Middle East: Call +44(0)870-330-6101
For all other areas visit our website to find your nearest distributor.



NEW

Eskimo Cup

Make Your Last Sip Colder Than Your First



The Eskimo Cup accommodates a variety of beverages, including a 12-oz beer, 16.9-oz water and 16-oz soda.

The Dometic Eskimo Cup is a refrigerated cup holder that can be installed in any convenient location to keep drinks refrigerator-cold (results may vary based on environmental conditions).

The Eskimo Cup makes your last sip even colder than your first. It allows boaters to keep a can, bottle or any appropriately sized beverage container chilled on even the hottest days—something that a typical cup holder or can koozie can't begin to accomplish. Simply store your drink in the Eskimo Cup between sips.

Designed as a marine-tough open-top cylinder that replaces nearly any existing standard 4-inch (102 mm) cup holder, it is large enough to fit a 20-ounce (591 ml) water or soda bottle, and also accommodates a standard-size beer or soda can. A specially angled bottom insert keeps bottles or cans in constant physical contact with the sidewall cooling element.

The Eskimo Cup is designed to accommodate mounting into surfaces of various thicknesses. A polished marine-quality 316 stainless steel trim ring finishes the surface installation and is accented with two blue LED interior lights. The aluminum interior has a corrosion-resistant, non-stick surface for easy cleaning and a built-in drain eliminates condensation, rain, and water splashes.

Beneath the installation surface, the aluminum interior is chilled by a DC-powered premium thermoelectric Peltier element and insulated for maximum effectiveness. The electronics are completely sealed and protected against water spray. The below-surface installation area requires ventilation for heat dissipation, so the area should not be fully enclosed.

Powered by the house battery, control of all the Eskimo Cups can be managed under a single switch or set up by zone. Each unit includes a low-voltage cut off to avoid a dead battery, a high-heat cut off, and an in-line fuse.



The Eskimo Cup features two blue LED interior lights.



The Eskimo Cup's electronics are completely sealed and protected from salt spray.



Aluminum interior of the Eskimo Cup has corrosion-resistant, non-stick surface with built-in drain.

Key Benefits

- Keep drinks refrigerator-cold
- Maintains or reduces temperature of cold drinks
- Replaces most standard cup holders
- Holds bottles or cans
- Polished marine-quality 316 stainless-steel trim ring
- Two blue LED interior lights
- Mounts into surfaces of various thicknesses
- DC-powered premium thermoelectric Peltier cooling element
- Marine-tough
- Built-in drain
- Low-voltage cut off, high-heat cut off, and in-line fuse

Product Testimonial

"The Dometic Eskimo Cup is a game changer. I have a tumbler that I fill with ice and water. It fits snugly into the Eskimo Cup and it stayed cold all day long, and even had ice in it at the end of the day. Later I put a Corona bottle in there, and same thing, it stayed cold. I have one on my boat now but I'm definitely going to install another one."

— Greg Lentine, owner, 24-foot Yellowfin Bay Boat

Specifications for Dometic Eskimo Cup

| Part Number | Amps | Power | Height (in/mm) | Width (in/mm) | Depth (in/mm) | Interior Diameter (in/mm) | Cutout Diameter (in/mm) | Power Cord Length (in/mm) | Weight (lbs/kg) |
|-------------|------|--------|----------------|---------------|---------------|---------------------------|-------------------------|---------------------------|-----------------|
| 250140101 | 3.1 | 12V DC | 6.23/159 | 5.36/137 | 6.85/174 | 2.95/75 | 4.0/102 | 16/407 | 2.11/0.96 |

Dimensions

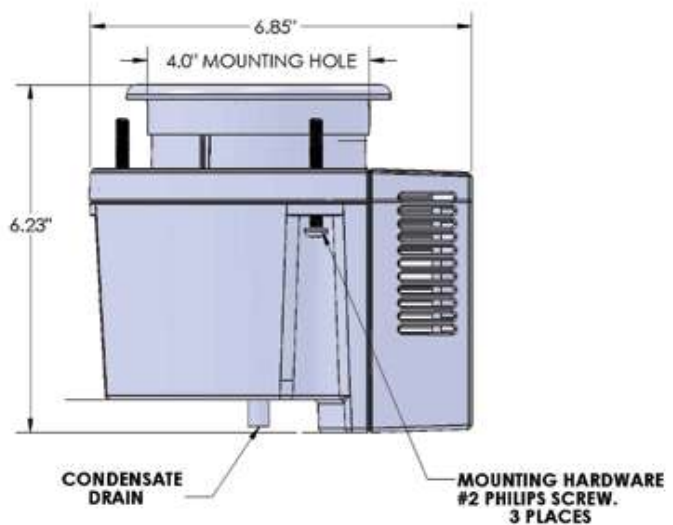
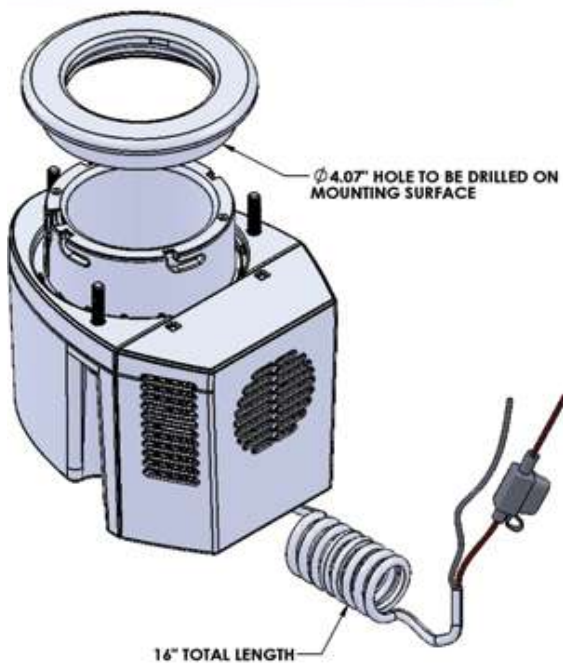
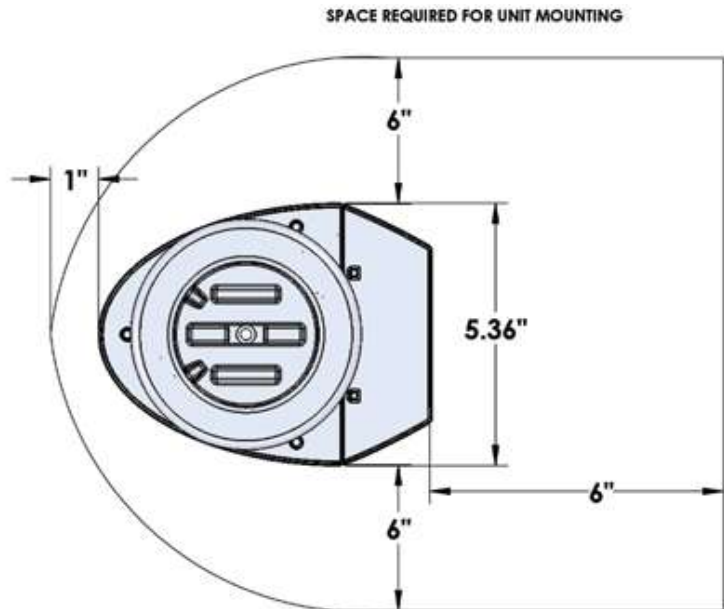
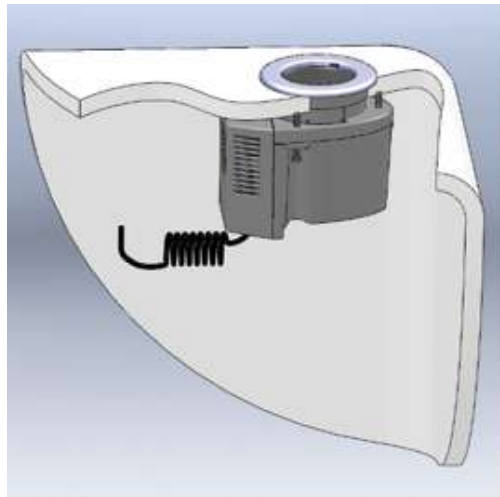

DOMETIC MARINE DIVISION

2000 N. Andrews Ave. Ext. | Pompano Beach, FL 33069 USA | Tel. 954-973-2477 | Fax: 954-979-4414
 www.Dometic.com/Marine | MarineSales@DometicUSA.com

24/7 TECH SUPPORT FOR UNITED STATES & CANADA:

8:00 AM to 5:00 PM Eastern Time: 800-542-2477
 After hours and weekends: 888-440-4494

INTERNATIONAL SALES & SERVICES

Europe & the Middle East: Call +44(0)870-330-6101
 For all other areas visit our website to find your nearest distributor.

Dealer