

HMDL Series Auxiliary Heat Modules

Providing Additional Ductable Heating In Cold Conditions



Cruisair auxiliary heat modules provide additional heating when the boat is in extremely cold seawater. They also permit specific compartments on the boat to be heated when the circulated water system is in the cooling mode.

The modules are installed on the discharge side of the air handler. Safety features include: fin tube heating elements with relatively low surface temperature, high temperature insulation on interior of unit, and two-stage thermal protection.

Air handling units are available with integral electrical heat (CHBB Type).

Key Benefits

- Electric resistance heat modules
- Up to 4 kW electric heat
- 115V and 230V operation
- Fin tube heating elements
- Two-stage thermal protection
- High-temperature thermal protection
- Installed in flexible or built-in duct
- Used with ducted air handlers

Specifications for HMDL Series Auxiliary Heat Modules

Model ⁽¹⁾	HMDL1-5	HMDL1C-5	HMDL1.5-6	HMDL1.5C-6	HMDL1.5-7	HMDL1.5C-7	HMDL2-7	HMDL2C-7	HMDL3C-8	HMDL4DC-9
Voltage (V)	115	230	115	230	115	230	115	230	230	230
Cycle (Hz)/Phase (Ph)	60/1	60/1	60/1	60/1	60/1	60/1	60/1	60/1	60/1	60/3
Heater Amps (A)	8.7	4.4	13	6.5	13	6.5	17.4	8.7	13	10
Max. Circuit Breaker (A)	15	10	25	10	25	10	35	15	25	20
Min. Circuit Ampacity (A)	11	6	17	9	17	9	22	11	17	13
Height (in/mm) ⁽²⁾⁽³⁾	7/178	7/178	7.8/199	7.8/199	7.8/199	7.8/199	7.8/199	7.8/199	9.6/244	9.6/244
Width (in/mm) ⁽³⁾	11.9/303	11.9/303	13.3/338	13.3/338	13.4/341	13.4/341	13.4/341	13.4/341	15.5/394	15.5/394
Depth (in/mm) ⁽³⁾	9.9/252	9.9/252	10.1/257	10.1/257	9.9/252	9.9/252	9.9/252	9.9/252	11.9/303	12/305
Fits Duct Size (in/mm)	5/127	5/127	6/153	6/153	7/178	7/178	7/178	7/178	8/204	9/229
Gross Weight (lbs)	10.5	10.5	10.5	10.5	10.5	10.5	10.5	10.5	14	13

¹ Interpreting HMDL model numbers: 'HM' = Heat Module; 'D' = Ducted; '1' to '4' = kW of electric heat; 'C' = 230V; No 'C' = 115V; 'DC' = 230V 3-phase; '-5' to '-8' = Duct size in inches.

² Height does not include mounting grommets.

³ All dimensions ± 0.25 in. (6 mm).

Dimensions

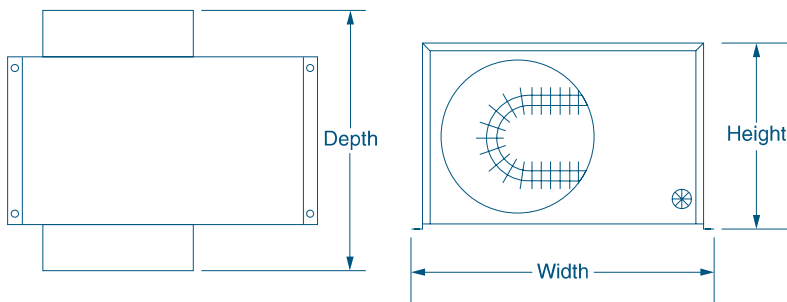

DOMETIC MARINE DIVISION
 2000 N. Andrews Ave. Ext. | Pompano Beach, FL 33069 USA | Tel. 954-973-2477 | Fax: 954-979-4414
 www.Dometic.com/Marine | MarineSales@DometicUSA.com

24/7 TECH SUPPORT FOR UNITED STATES & CANADA:
 8:00 AM to 5:00 PM Eastern Time: 800-542-2477
 After hours and weekends: 888-440-4494

INTERNATIONAL SALES & SERVICES
 Europe & the Middle East: Call +44(0)870-330-6101
 For all other areas visit our website to find your nearest distributor.

L-0622 Rev. 20130419

Specifications and availability subject to change without notice.

