



PRODUCT CATALOG



Maretron[®]
Vessel Monitoring & Control Systems



www.maretron.com

Contents

PRODUCT CATALOG

Maretron, a world leader in vessel monitoring and control systems, designs, manufactures, and markets leading edge products for commercial and recreational marine markets. Our products are highly integrated to provide a common user interface to the equipment and systems commonly found onboard a vessel. Maretron's corporate philosophy is to provide premium quality, state-of-the-art vessel monitoring and control products that work in conjunction with traditional navigation and monitoring techniques for the highest level of safety and performance while on the water.

-  ***User Interface Software Products***
-  ***User Interface Hardware Products***
-  ***NMEA 2000® Gateways and Bridges***
-  ***Tank Monitoring***
-  ***Engine Monitoring***
-  ***Electrical Monitoring and Control***
-  ***General Systems
Monitoring and Recording***
-  ***Navigation Instruments***
-  ***Cables and Connectors***
-  ***Network Installation Guide***

866-550-9100

World-class standards in vessel monitoring and control systems.

*Simpler, safer, and more secure boating.
These are the guiding principles of Maretron.*

We understand that a vessel is made up of many complex systems including the engine, transmission, generators, electrical, and much, much more. Trying to keep track of this equipment to ensure a safe and secure journey can be overwhelming. Without the appropriate vessel monitoring and control system, small issues can quickly turn into dangerous situations, and can even become life-threatening. Further complicating the task at hand or the different user interfaces for each piece of equipment, all having various gauges, buttons, and ways to setup and acknowledge alarms.

At Maretron, we have developed a single, common interface to monitor and control your vessel's systems so you don't have to learn and remember different ways to interact with each piece of equipment. And with a built-in comprehensive alert system, you don't have to sit and stare at the gauges because you will get an alarm or warning at the slightest hint of a problem, before it turns into a larger, more serious issue. Look at it as your very own "second mate" or "engineer," continuously watching over your vessel 24 hours a day, 7 days a week, 365 days a year. Additional key features include:

- **Safety** – alarms for fire, smoke, combustible gases, carbon monoxide and high bilge water
- **Security** – includes cameras, motion detectors, and magnetic door and port hole sensors
- **Ease of use** – provides one simple, common user interface for all systems
- **Remote monitoring and notification** – includes monitoring remotely plus video, email and text notifications
- **Future support** – easily expandable systems grow with your needs

Maretron. *Providing solutions for all of your vessel monitoring and control needs.*

www.maretron.com



Networked Systems Benefits

Maretron's products communicate over a Controller Area Network (CAN bus) using the National Marine Electronics Association's NMEA 2000® protocol. The advantages of using CAN bus are numerous and include low wiring complexity with all components interconnected through a single cabling system. The reduction in wire over conventional systems is significant, resulting in lower installation and maintenance cost and lower overall vessel weight. And since the individual products are connected to drop lines from the main trunk line, a single product failure doesn't affect communication among other devices. In addition, the CAN bus easily accommodates adding products to the network for future expansion. Probably most importantly, you are no longer constrained to viewing your vessel's information from an independent system from a single place using a single display. With Maretron's networked solutions, you simply place a display anywhere on the network – whether it is at the helm, in the engine room, or sleeping quarters – and you are free to monitor and control anything connected to the network from anywhere on the vessel.

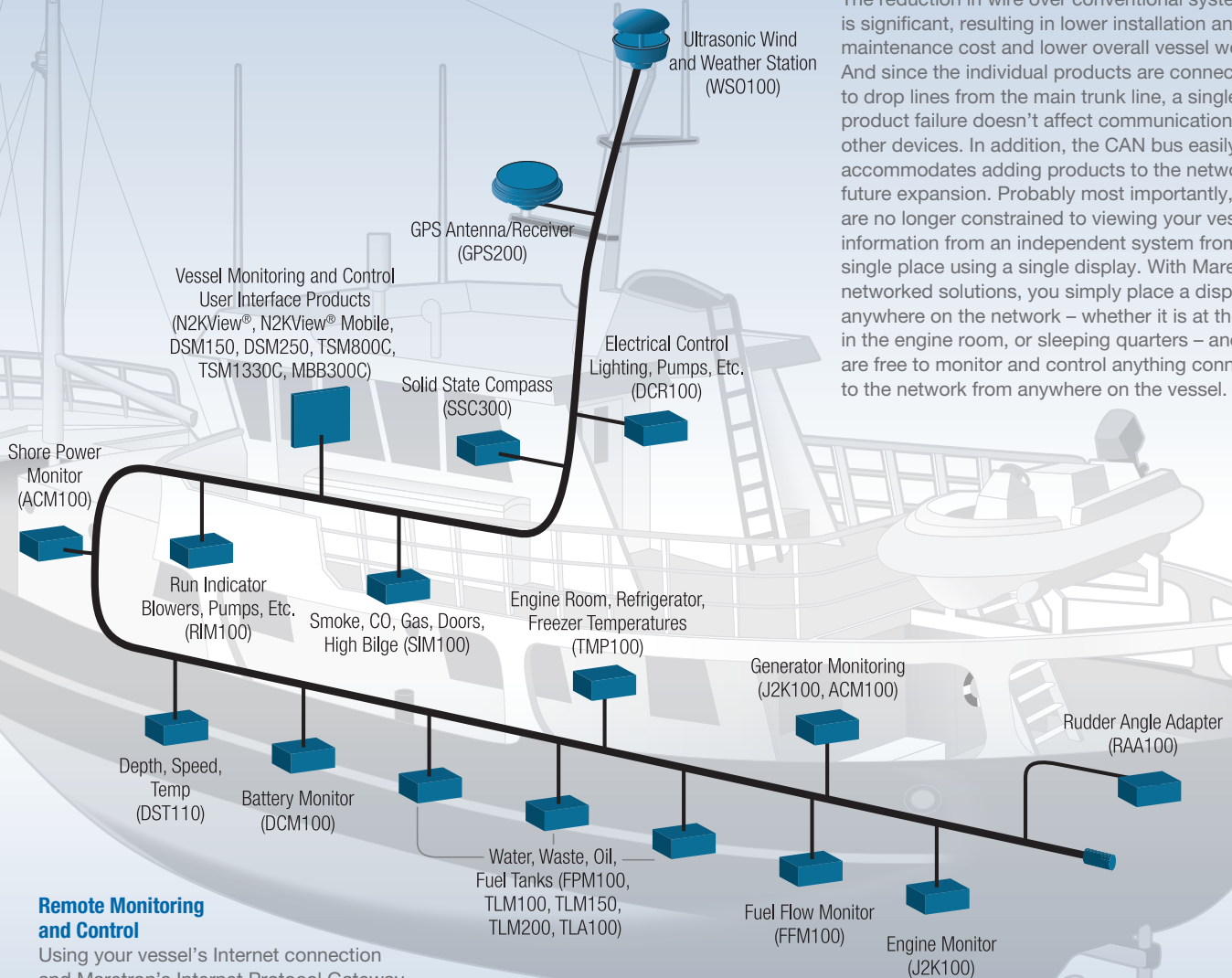

Remote Monitoring and Control

Using your vessel's Internet connection and Maretron's Internet Protocol Gateway (IPG100), you can stay connected to your vessel from anywhere in the world. Imagine receiving an email or text notification indicating high bilge water or a motion sensor alarm and you simply log onto the vessel with your smart phone, tablet, or PC and start an auxiliary bilge pump or switch on a light to scare off intruders. You can even watch live video feeds from the vessel so you can keep an eye on the vessel from anywhere in the world.

User Interface Software Products

N2KView® - *Vessel Monitoring and Control Software*

N2KView® Mobile - *Vessel Monitoring and Control Software*

Real Time Cloud Service - *Remote Vessel Monitoring and Control*

N2KTracker™ - *Smartphone/Tablet Vessel Tracking*

Telemetric Cloud Service - *Vessel Tracking and Asset Management*

If you think about all the systems onboard a vessel and what needs to be monitored to keep each person safe, secure, and comfortable, it can be a daunting task. Is there enough fuel to make it to the destination, is the engine overheating, is the bilge filling up with water, is there carbon monoxide in the sleeping quarters? Maretron offers user interface products that dramatically reduce the stress associated with keeping track of all your systems. In fact, every single parameter from every system onboard can be monitored 24/7 using programmable alerts or alarms, which gives you an early warning of potential problems before they become an annoyance or even a threatening situation. Furthermore, all vessel system information is available through one highly intuitive and configurable user interface so you don't have to learn how to operate multiple disparate systems. And all the vessel monitoring and control information is networked, so you can get the data wherever it's needed, whether it be onboard or ashore, using desktop computers, laptops, handhelds, or tablets.



N2KView®

Vessel Monitoring and Control Software



N2KView® Mobile

Vessel Monitoring and Control Software



N2KTracker™ Mobile

Smartphone/Tablet Vessel Tracking



N2KView®

Vessel Monitoring and Control Software

Whether you are interested in monitoring your vessel's systems while underway or remotely from your home or office, Maretron's N2KView® software displays the information you need including engines, generators, tanks, rudders, navigation instruments, local weather, and much, much more. N2KView® is completely user-configurable and you are free to create different screens for your exact needs while easily switching from screen to screen for monitoring all your systems. Digital displays, analog gauges, graphic displays, warning lights, and bar graphs,



all can be configured exactly how you want them to be. You can even set the operating limits and color bands for analog gauges so you know when things are within limits and when they are not.

N2KView® is a comprehensive vessel monitoring and control software that goes beyond simple monitoring. With N2KView® you get additional functionality including alerts, video, control, and fuel management. The alerts functionality allows you to set up as many warnings and alarms as you need so you can be forewarned of potential problems. With alerts, you can relax knowing that the system is watching for smoke, CO, high bilge water,

Products

PART NUMBER	DESCRIPTION
N2KView	N2KView® Vessel Monitoring and Control Software for Personal Computer

or anything else you deem important. N2KView® video capability allows you to add cameras as part of the monitoring system - for example a camera in the engine room - or the cameras can be used as part of the security system. The control functionality gives you the ability to manage your electrical system; for example, you can turn lights or pumps on or off directly from N2KView® and even tell if the lights or pumps are burned out and not working. Lastly, the fuel management function uses information from the fuel flow monitor, tank monitors, and GPS to provide advanced information like distance and time to empty as well as fuel rate and fuel economy.

N2KView® software can run on your vessel's computer or on standalone products like the Maretron's TSM800C and TSM1330C displays (see pages 20 and 22), or the Maretron Black Box (MBB300C) vessel monitoring system (see page 24). If you want to run N2KView® software on your vessel's computer, you will need either a Maretron USB100 (page 36) or an IPG100 (page 38), which are necessary to get sensor information from the NMEA 2000® network to the computer.

Windows PC Server/Client System Requirements

Parameter	Value	Comment
Operating System	Windows XP SP3/Vista/7/8 and MAC OS	Latest Service Packs may be Required for Support
CPU Minimum	Intel Atom	
CPU Recommended	Intel CORE i3	
Memory Minimum	512MB RAM	
Memory Recommended	1GB Ram	
Hard Drive Space	100 MB	
CD-ROM, or DVD Drive	Single	Required to Load Software from Shipped Media
Video Card Minimum	128 MB	
Video Card Recommended	256 MB	
USB Ports	1.1 or 2.0 Compatible	Only Required if connecting through USB100
Ethernet Ports	10/100/1000BASE-TX or 802.11a/b/g/n	Only Required if connecting through IPG100
Display Minimum	800x480 Resolution 32-bit Color Video	



Navigation

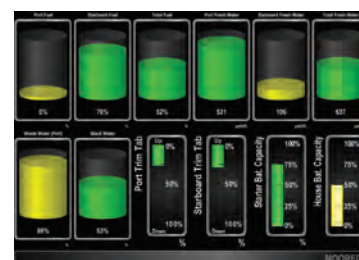

Tank Levels



AC Systems



DC Systems

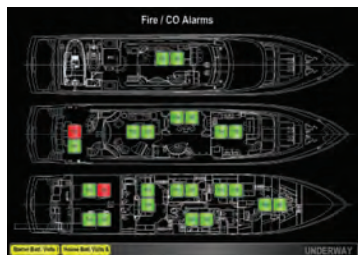

Fire Alarms



Environment



Engines

N2KView® Mobile

Maretron's N2KView® Mobile software allows you to monitor and control your vessel's systems from your smart phone or tablet device. This includes Android (2.2 and higher) smart phones and tablets as well as Apple iPod, iPhone, and iPad. Whether it's onboard via WiFi or ashore via an Internet connection, you can see what is happening aboard your vessel and even control things like your air conditioner, watermaker, lights, pumps, and more.

What makes N2KView® Mobile so diverse is its ability to configure your own screens. You have complete control of the number of screens, the layout of each screen, and the size and type of each parameter you wish to display. You customize each display exactly the way you want it. You use N2KView® on a computer to design the screens, and then download them to your smart phone or tablet device.



N2KView® Mobile may be downloaded free of charge directly from Google Play to your Android device or directly to an Apple device from the iTunes store. Although the application is a free download, you will need a Maretron Internet Protocol Gateway (IPG100 – page 38) to get the sensor data onto the vessels Wifi for onboard viewing or onto the Internet for remote viewing.

Products

PART NUMBER	DESCRIPTION
N2KView® Mobile Android	Free Download from Google Play/Amazon app Store
N2KView® Mobile Apple	Free Download from iTunes





N2KView® Mobile for Apple iPod, iPhone, iPad

Parameter	Value	Comment
Hardware	iPod Touch, 3rd or 4th Generation	
	iPod Touch 32 or 64GB, 2nd Gen.	N2KView Mobile version 3.2 is still available for 2nd generation iPods
	iPhone 3G-S, iPhone 4 or later	
	iPad, iPad 2, or later	
Operating System	iOS 4.0 or later	
	iOS 3.0 or later	N2KView Mobile version 3.2 is still available for devices running iOS 3.x
Image Size	16.4 Mbytes	
Screen orientations	Portrait and landscape	
Connection to N2KServer	Encrypted using SSL encryption	

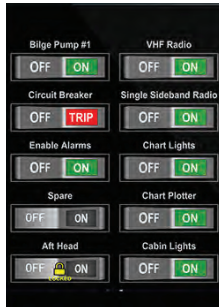

N2KView® Mobile for Android

Parameter	Value	Comment
Hardware	Any Hardware running Android OS	
Operating System	Android Version 2.2 (Froyo) or later	
Image Size	17.4 Mbytes	
Screen Orientations	Portrait and landscape	
Connection to N2KServer	Encrypted using SSL encryption	

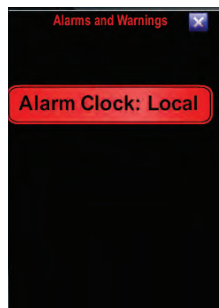
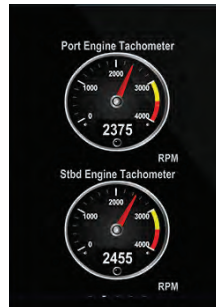

Maretron Real Time Cloud Service

Maretron Real Time Cloud Service allows you to remotely and seamlessly connect to your vessel using N2KView® or N2KView® Mobile software so you can monitor and control your vessel from anywhere in the world. As long as there is an Internet connection to the vessel, Maretron's Internet Protocol Gateway (IPG100) will automatically log into Maretron's Internet real time cloud server and the vessel's information will be made available to any remote N2KView® or N2KView® Mobile. Connection between your vessel and remote N2KView® software has never been easier, whether your vessel's Internet connection is via a marina WiFi, satellite connection, GSM or cell phone modem, or any other type of Internet connection, you'll have access to the vessel from anywhere in the world.



Products

PART NUMBER	DESCRIPTION
MCS-25GB	Remote Vessel Monitoring & Control Data Plan (1 Year Contract Required-25GB/month)
MCS-50GB	Remote Vessel Monitoring & Control Data Plan (1 Year Contract Required-50GB/month)
MCS-100GB	Remote Vessel Monitoring & Control Data Plan (1 Year Contract Required-100GB/month)



Using Maretron Real Time Cloud Service is simple, just imagine receiving an email or text notification from the vessel indicating a problem and you simply log onto the vessel using a smart phone, tablet, or PC. Using Maretron's N2KView® vessel monitoring and control software you get a better understanding of the problem and you can even initiate a corrective action like resetting tripped breakers, turning on auxiliary pumps or lights. Or maybe you just want to adjust the air conditioner or start the ice maker on your way to the boat. Whatever the reason, Maretron Real Time Cloud Service provides you with a seamless connection to your vessel for peace of mind and convenient access from anywhere in the world.

Multiple Wired and Wireless Devices Running N2KView® and N2KView® Mobile Vessel Monitoring and Control Software

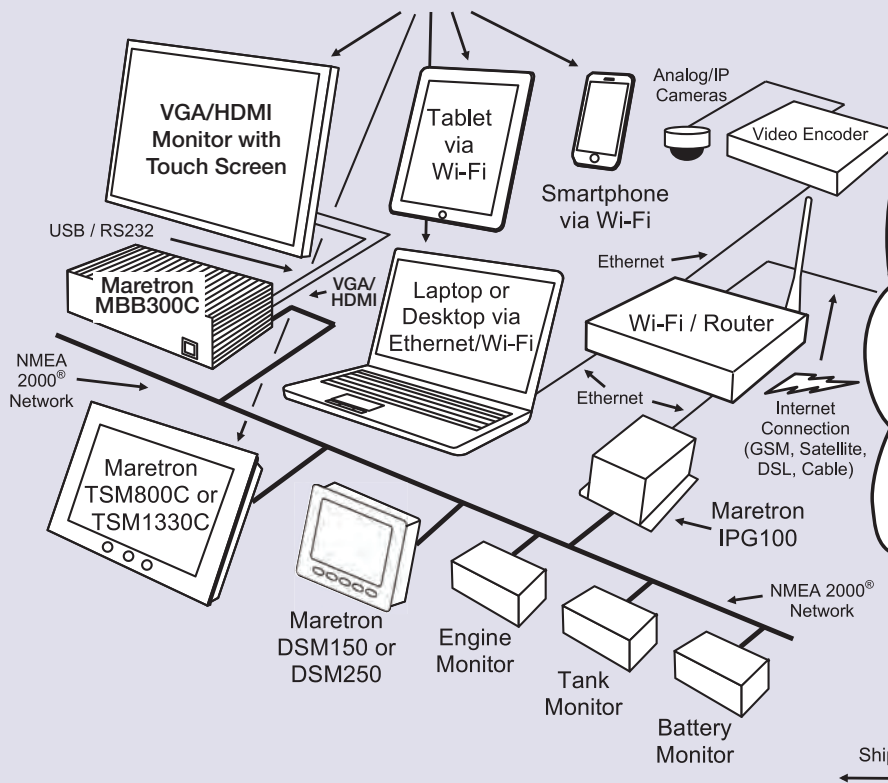

Remote Wired and Wireless Devices Running N2KView® and N2KView® Mobile

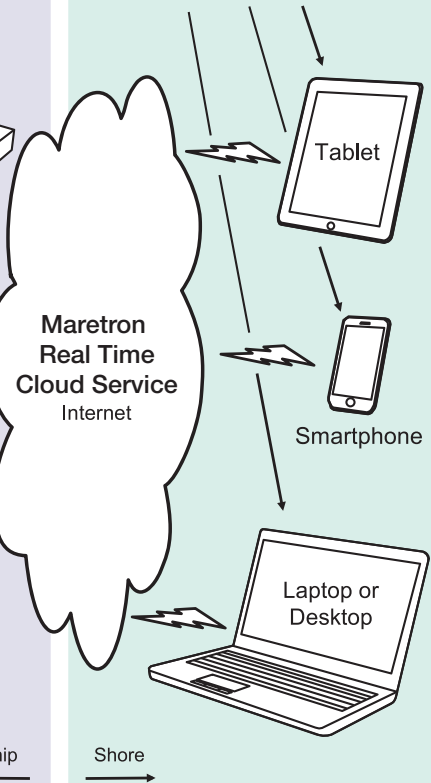

Maretron Real Time Cloud Service Diagram



N2KTracker™

Track Your Vessel on a Smartphone

N2KTracker™ is a free App that shows your boat's position and recent track on a Google map. It also allows you to create, enable, and disable a geo-fence around your boat's position so that you or others can be alerted if your boat leaves a specified area, and allows you to enable and disable notifications via e-mail or SMS text message.

N2KTracker™ also has a dashboard function so that you can select any data stored on the cloud for viewing, such as engine hours for maintenance tracking, fuel levels for cost management, engine parameters so that you can ensure proper operational procedures are being followed, or bilge pump runtime to ensure your boat will remain safely afloat.



N2KTracker™ works equally well whether you have a single boat and want to share your voyage with friends, or if you manage a fleet, allowing you to quickly and easily change the selection of the vessel you are viewing.

Products

PART NUMBER	DESCRIPTION
N2KTracker Android	Free Download from Google Play/Amazon app Store
N2KTracker Apple	Free Download from iTunes



N2KTracker™ for Android

Parameter	Value
Hardware	Any Hardware Running Android OS
Operating System	Android version 4 (Ice Cream Sandwich) or higher
File Size	3.4 MB
Screen Orientation	Portrait or Landscape
Connection to Maretron Telemetric Cloud Service	SSL Encrypted

N2KTracker™ for Apple iOS

Parameter	Value
Hardware	iPhone / iPad
Operating System	iOS 8 or higher
File Size	21.8 MB
Screen Orientation	Portrait or Landscape
Connection to Maretron Telemetric Cloud Service	SSL Encrypted

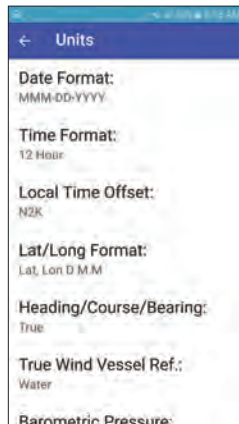
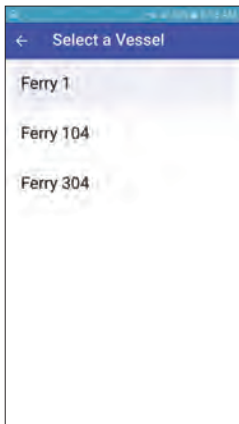
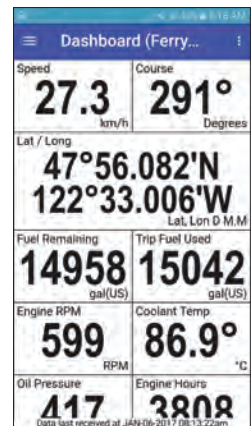
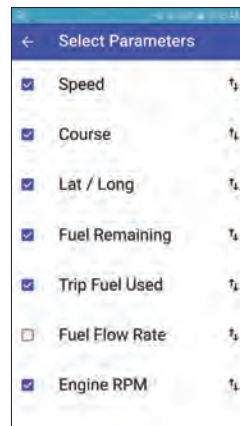
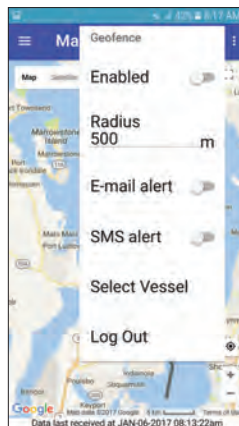

Telemetric Cloud Service

Maretron Telemetric Cloud Service uses the vessel's existing Internet connection (cellular, Wi-Fi, satellite, etc.) to broadcast information about the vessel to Maretron's Cloud Server where the data is stored and subsequently accessed from the shore via a computer, smartphone, or tablet device. Using Maretron Telemetric Cloud Service allows you to protect your investment through near real-time tracking of your vessel and it allows you to manage the operation of your assets such as scheduling preventive maintenance or optimizing performance such as fuel usage.

The type of data transmitted off the vessel is limited only by the Maretron NMEA 2000® sensors making up the onboard vessel monitoring system. This might be as simple as a single GPS antenna/receiver used for tracking the vessel, or it may include many sensors for monitoring engines, generators, fuel rate, tank levels, batteries, and more. Selecting which data is monitored and how often it is transmitted to the cloud from the vessel is a simple matter using a Maretron touchscreen or black box (TSM800C,



TSM1330C, or MBB300C). This gives you the flexibility to decide which information is important and how often it is transmitted while balancing it against your airtime cost. The system has been designed to be extremely efficient for minimizing airtime, plus the system is designed to be very robust for situations where Internet connectivity is intermittent or moving through areas of spotty coverage.

With regard to accessing cloud data from ashore, there are two methods. First, there is a free smartphone/tablet application called N2KTracker™, which is a Google map showing your boat's current position and its track over the last hour. You can set a geo-fence so if the boat moves outside your programmed circle radius, you'll get a text message or email notifying you that the vessel is on the move. N2KTracker™ also has a dashboard function where you can select any data stored in the cloud for display. For a more detailed analysis of the data stored in the cloud, Maretron offers a free PC-based software program called N2KExtractor®. N2KExtractor® shows the boat and track on a map for the selected time period, plus it allows you to graph up to four parameters while correlating the data with the vessel's position. Alternatively, N2KExtractor® allows any number of user selected parameters for a user selected time period to be extracted in the form of a spreadsheet file for detailed performance analysis or preventive maintenance.

So if you are looking to protect your investment through vessel tracking, or if you are looking to manage your assets using performance analysis or preventive maintenance, then Maretron Telemetric Cloud Service provides you with ready access to the data you need.

Commercial Application



Vessel's Existing Internet Connection

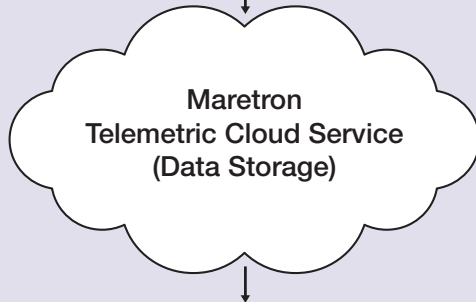

N2KExtractor®
(PC Software for Data Analysis)

Recreational Application



Vessel's Existing Internet Connection

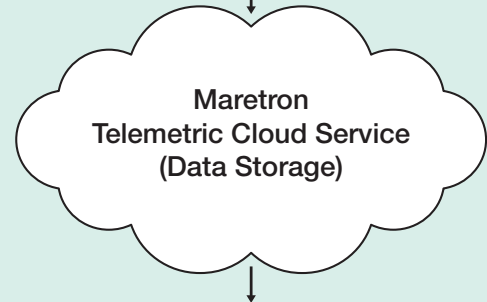

N2KTracker™
(Android/Apple App)

Telemetric Cloud Service Diagram



User Interface Hardware Products

TSM800C - 8" Vessel Monitoring and Control Touchscreen

TSM1330C - 13.3" Vessel Monitoring and Control Touchscreen

MBB300C - Black Box Vessel Monitoring and Control

DSM150 - 3.5" High Bright Color Display

DSM250 - Multi-Function Color Display

ALM100 - Alarm Module

SMS100 - Short Message Service (Text) Module

If you think about all the systems onboard a vessel and what needs to be monitored to keep each person safe, secure, and comfortable, it can be a daunting task. Is there enough fuel to make it to the destination, is the engine overheating, is the bilge filling up with water, is there carbon monoxide in the sleeping quarters? Maretron offers user interface products that dramatically reduce the stress associated with keeping track of all your systems. In fact, every single parameter from every system onboard can be monitored 24/7 using programmable alerts or alarms, which gives you an early warning of potential problems before they become an annoyance or even a threatening situation. Furthermore, all vessel system information is available through one highly intuitive and configurable user interface so you don't have to learn how to operate multiple disparate systems. And all the vessel monitoring and control information is networked, so you can get the data wherever it's needed, whether it be onboard or ashore, using desktop computers, laptops, handhelds, or tablets.



TSM800C

8" Vessel Monitoring and Control Touchscreen



TSM1330C

13.3" Vessel Monitoring and Control Touchscreen



MBB300C

Black Box Vessel Monitoring and Control



DSM150

3.5" High Bright Color Display



DSM250

5.7" Multi-Function Color Display



ALM100

Alarm Module



SMS100

Short Message Service (text) Module



TSM800C *8" Vessel Monitoring and Control Touchscreen*

The TSM800C is an 8" dedicated touchscreen that includes Maretron's N2KView® vessel monitoring and control software. The N2KView® software allows you to configure as many favorite screens as you want with exactly the information you want to see. The TSM800C provides an extremely simple touch interface for monitoring and controlling critical systems from anywhere on the vessel.

The TSM800C is ruggedized for marine use and includes a solid state disk drive to withstand the pounding associated with waves. And since the TSM800C only dissipates 20 watts, there is no need for internal cooling fans that are noisy and wear out causing electronics to overheat and fail. The TSM800C can be mounted outside given the high bright screen and waterproof front.

As an alternative to controlling the TSM800C through the touch screen, the TSM800C includes two USB ports for connecting keyboards, mice, or trackballs. The TSM800C also has an Ethernet port for connecting Internet Protocol (IP) cameras for viewing within the N2KView® software. Lastly, the TSM800C contains two completely isolated CAN bus connectors (M12) for easy connection to single or redundant NMEA 2000® networks.



TSM800C features:

- 8" TFT LCD Panel, LED Backlit
- Widescreen Aspect Ratio 5:3
- 800 x 480 Pixels
- 600 nits Brightness (Optically Bonded)
- Solid State Disk Drive
- Fanless Cooling System
- Flush or VESA Mounting
- Dual CAN Bus for Single or Redundant NMEA 2000® Network Connections

Products

PART NUMBER	DESCRIPTION
TSM800C-01	8" Vessel Monitoring and Control Touchscreen (Direct NMEA 2000 Connection)

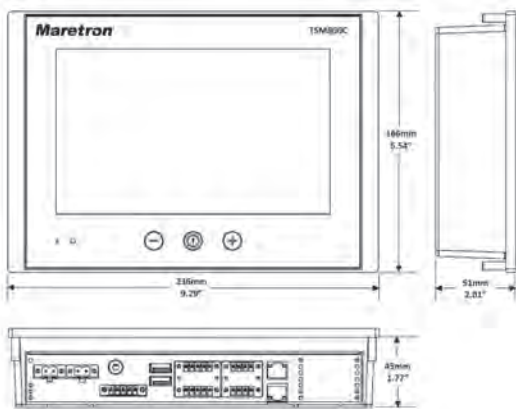

Specifications

Parameter	Value	Comment
Display Size	8"	LED Backlit LCD with Projected Capacitive Touch Screen
Display Resolution	800x480	WVGA
Display Brightness	600cd/m2	Optically Bonded
Contrast Ratio	600:1	
LCD Color	262K	
Viewing Angle	70° H, 60° V	
USB Ports	Two USB 2.0	
Ethernet Ports	One RJ-45 GbE	For connection to Maretron IPG100 or router
Controller Area Network (CAN) Ports	Two Waterproof (M12)	Dual NMEA 2000® Connection
Compass Safe Distance	45cm	Standard
	25cm	Steering

Approvals

Parameter	Comment
IEC 60945	
GL – Germanischer Lloyd	
BV – Bureau Veritas	
IACS E10	
DNV – Det Norske Veritas	
LRS – Lloyd's Register of Shipping	Pending
ClassNK – Nippon Kaiji Kyoaki	
ABS – American Bureau of Shipping	
NMEA 2000®	

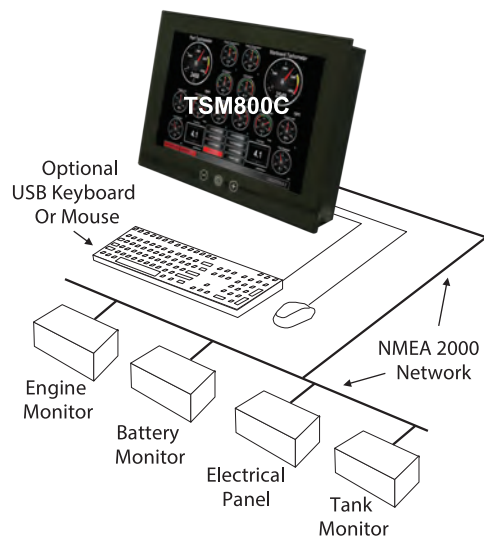

Electrical

Parameter	Value	Comment
Operating Voltage (Dedicated Supply Connection)	18-32 Volts	DC Voltage, Dual Inputs
Power Consumption (Dedicated Supply Connection)	20 Watts	Typical
	30 Watts	Maximum
Operating Voltage (NMEA 2000® Connection)	8 – 32 Volts	DC Voltage
Power Consumption (NMEA 2000® Connection)	50mA	
Load Equivalence Number (LEN)	1	NMEA 2000® Spec. (1 LEN = 50 mA)
Reverse Battery Protection (NMEA 2000® Connection)	Yes	Indefinitely
Load Dump Protection (NMEA 2000® Connection)	Yes	Energy Rated per SAE J1113

Mechanical

Parameter	Value	Comment
Overall Dimensions (DxWxH)	2.01" x 9.29" x 6.54" (51mm x 236mm x 166mm)	
Weight	4.2 lbs (1.9kg)	
Front Panel Material	Glass	
Front Panel Controls	Power, Brightness +/-	
Mounting	4 x M4 VESA Mounting 75mm x 75mm	Max 8mm deep
	Built-in Console Mounting	4 x M5 x 15mm screws

Environmental

Parameter	Value
Operating Temperature	-15°C to 55°C (Humidity up to 95%)
Storage Temperature	-20°C to 60°C (Humidity up to 95%)
IP Rating	IP66 Front, IP22 Rear (EN60529)

TSM800C Screen Shots

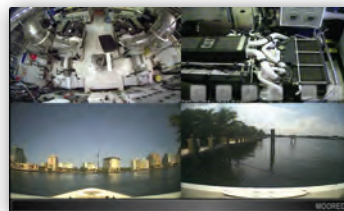

TSM1330C 13.3" Vessel Monitoring and Control Touchscreen

The TSM1330C is a 13.3" dedicated touchscreen that includes Maretron's N2KView® vessel monitoring and control software. The N2KView® software allows you to configure as many favorite screens as you want with exactly the information you want to see. The TSM1330C provides an extremely simple touch interface for monitoring and controlling critical systems from anywhere on the vessel.

The TSM1330C is ruggedized for marine use and includes a solid state disk drive to withstand the pounding associated with waves. And since the TSM1330C only dissipates 20 watts, there is no need for internal cooling fans that are noisy and wear out causing electronics to overheat and fail. The TSM1330C can be mounted outside given the waterproof front.

As an alternative to controlling the TSM1330C through the touch screen, the TSM1330C includes two USB ports for connecting keyboards, mice, or trackballs. The TSM1330C also has an Ethernet port for connecting Internet Protocol (IP) cameras for viewing within the N2KView® software. Lastly, the TSM1330C contains two completely isolated CAN bus connectors (M12) for easy connection to single or redundant NMEA 2000® networks.



TSM1330C features:

- 13.3" TFT LCD Panel, CCFL Backlit
- Widescreen Aspect Ratio 16:10
- 1280 x 800 Pixels
- 400 nits Brightness (Optically Bonded)
- Solid State Disk Drive
- Fanless Cooling System
- Flush or VESA Mounting
- Dual CAN Bus for Single or Redundant NMEA 2000® Network Connections

Products

PART NUMBER	DESCRIPTION
TSM1330C-01	13.3" Vessel Monitoring and Control Touchscreen (Direct NMEA 2000 Connection)

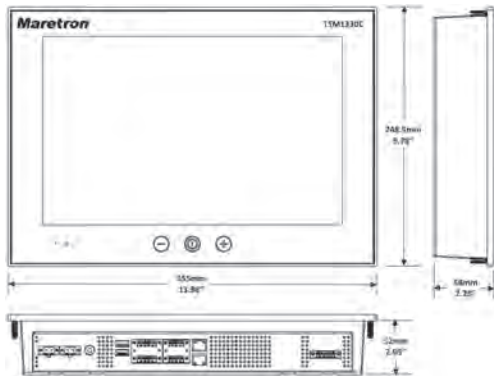

Specifications

Parameter	Value	Comment
Display Size	13.3"	CCFL Backlit LCD with Projected Capacitive Touch Screen
Display Resolution	1280x800	WXGA
Display Brightness	400cd/m2	Optically Bonded
Contrast Ratio	800:1	
LCD Color	262K	
Viewing Angle	70° H, 60° V	
USB Ports	Two USB 2.0	
Ethernet Ports	One RJ-45 GbE	For connection to Maretron IPG100 or router
Controller Area Network (CAN) Ports	Two Waterproof (M12)	Dual NMEA 2000® Connection
Compass Safe Distance	45cm	Standard
	25cm	Steering

Approvals

Parameter	Comment
IEC 60945	
GL – Germanischer Lloyd	
BV – Bureau Veritas	
IACS E10	
DNV - Det Norske Veritas	
LRS – Lloyd's Register of Shipping	Pending
ClassNK – Nippon Kaiji Kyoaki	
ABS – American Bureau of Shipping	
NMEA 2000®	

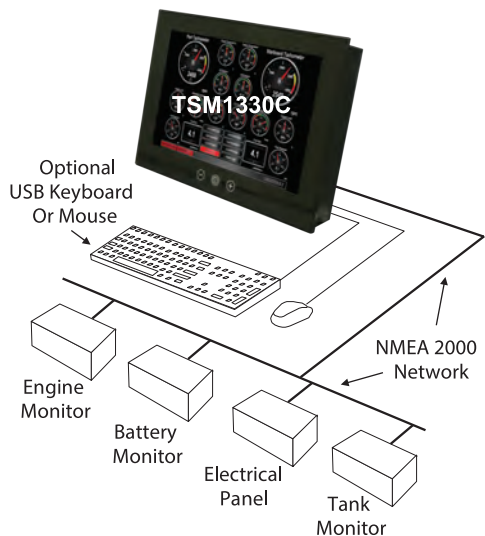

Electrical

Parameter	Value	Comment
Operating Voltage (Dedicated Supply Connection)	18-32 Volts	DC Voltage, Dual Inputs
Power Consumption (Dedicated Supply Connection)	20 Watts	Typical
	30 Watts	Maximum
Power Consumption (NMEA 2000® Connection)	50mA	Maximum When Transmitting 100%
Load Equivalence Number (LEN)	1	NMEA 2000® Spec. (1 LEN = 50 mA)
Reverse Battery Protection (NMEA 2000® Connection)	Yes	Indefinitely
Load Dump Protection (NMEA 2000® Connection)	Yes	Energy Rated per SAE J1113

Mechanical

Parameter	Value	Comment
Overall Dimensions (DxWxH)	2.28" x 13.98" x 9.78" (58mm x 355mm x 248.5mm)	
Weight	9.7 lbs (4.4kg)	
Front Panel Material	Glass	
Front Panel Controls	Power, Brightness +/-	
Mounting	4 x M4 VESA Mounting 75mm x 75mm	Max 8mm deep
	Built-in Console Mounting	4 x M5 x 15mm screws

Environmental

Parameter	Value
Operating Temperature	-15°C to 55°C (Humidity up to 95%)
Storage Temperature	-20°C to 60°C (Humidity up to 95%)
IP Rating	IP66 Front, IP22 Rear (EN60529)

TSM1330C Screen Shots

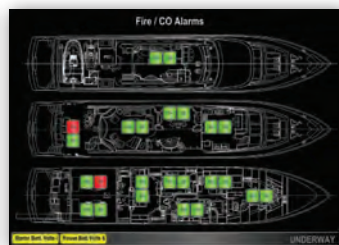

MBB300C *Maretron Black Box Vessel Monitoring and Control*

Maretron's third generation Black Box (MBB300C) is a dedicated processing unit that includes Maretron's N2KView® vessel monitoring and control software. Unlike a PC that allows any software to be loaded, the MBB300C runs only N2KView® software making it extremely stable and dedicated to monitoring and controlling your vessel.

The MBB300C is ruggedized for marine use and includes a solid state disk drive to withstand the pounding associated with waves. And since the MBB300C dissipates less than 10 watts, there is no need for internal cooling fans that are noisy and wear out causing electronics to overheat and fail.

The MBB300C connects to a monitor through a VGA connector or an HDMI connector while the associated touch screen connects through a USB or serial port. Alternatives to controlling the N2KView® software through a touch screen include keyboards, mice, or track balls connected through USB. In addition to the two completely isolated CAN bus connectors for simple connection to single or redundant NMEA 2000® networks, the MBB300C has an Ethernet port for connecting Internet Protocol (IP) cameras for viewing within the N2KView® software.



Of course you get the same flexibility using Maretron's N2KView® software from the MBB300C as you would running the software on a PC, which includes the ability to configure as many screens as you want with exactly the information you want to see. Plus you get free upgrades to the software as improvements and new features are added.

- 9-36 Volt Power Supply
- Solid State Disk Drive
- Fanless Cooling System
- Dual CAN Bus for Single or Redundant NMEA 2000® Network Connections
- Four USB Ports for Touchscreen, Keyboard, Mouse, Trackball, or Thumb Drive Connections
- VGA or HDMI Video Connection (2560 x 1600 Maximum Resolution)
- Ethernet Connector for IP Camera Input, Email Alert Notification, and Maretron Analytic Cloud Service

Products

PART NUMBER	DESCRIPTION
MBB300C-01	Black Box Vessel Monitoring and Control

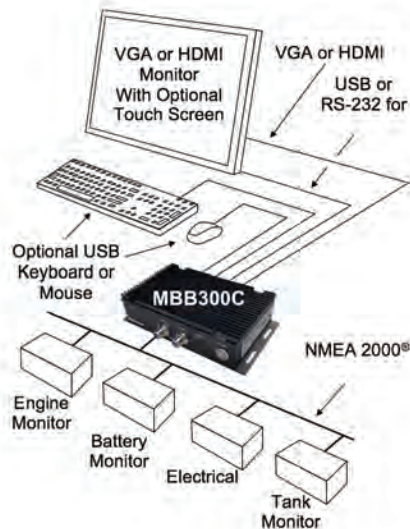
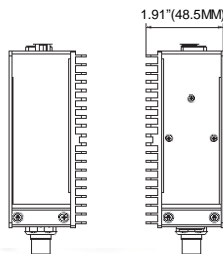
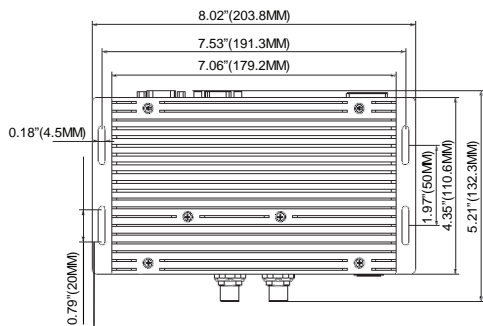

Specifications

Parameter	Value	Comment
Video Connector	VGA Port HDMI Port	For Monitor Connection
Monitor Resolution	2560 x 1600 Maximum (VGA) 1920 x 1080 Maximum (HDMI)	
USB Connector	Two USB 3.0 connections Two USB 2.0 connections	For connecting Peripherals (Mouse, keyboard, etc.) and/or touch screen connectivity
Serial Connector	One RS232 9-Pin D Connector	For touch screen alternative connection
Touchscreen Drivers	TSHARC, 3M MicroTouch, ELO, eGalax, General Touch	Compatible with HID touch compliant panels
Ethernet Connector	RJ-45 GbE	For connection to IP cameras
Controller Area Network (CAN) Ports	Two NMEA 2000 Micro-C Connectors	

Certifications

Parameter	Comment
FCC class A and CE Mark	Electromagnetic Compatibility
NMEA 2000®	

Electrical

Parameter	Value	Comment
Operating Voltage (Dedicated Supply Connection)	9–36 Volts	DC Voltage
Power Consumption (Dedicated Supply Connection)	10 Watts	Maximum
Operating Voltage (NMEA 2000® Connection)	8–32 Volts	DC Voltage
Power Consumption (NMEA 2000® Connection)	80 mA	Maximum When Transmitting 100%
Load Equivalence Number (LEN)	1	NMEA 2000® Spec. (1 LEN = 50 mA)
Reverse Battery Protection (NMEA 2000® Connection)	Yes	Indefinitely
Load Dump Protection (NMEA 2000® Connection)	Yes	Energy Rated per SAE J1113

Mechanical

Parameter	Value	Comment
Overall Dimensions (DxWxH)	5.21" x 8.02" x 1.91" (132.3mm x 203.8mm x 48.5mm)	Excluding Connectors and Wall Brackets
Weight	2.27 lbs (1.03 kg)	
Chassis Material	Aluminum	
Mounting	VESA 100, Wall Bracket, DIN Rail	Any Orientation

Environmental

Parameter	Value
Operating Temperature	-20°C to 70°C
Storage Temperature	-40°C to 85°C
Humidity	10%–85% RH non-condensing



Copyright 2017 Maretron, LLP. All rights reserved. As Maretron is constantly improving its products, all specifications are subject to change without notice. Maretron's products are designed to be accurate and reliable; however, they should be used only as aids to navigation and vessel monitoring, and not as a replacement for traditional navigation and vessel monitoring techniques. A prudent captain or navigator never relies on a single source for navigation or system monitoring information. "NMEA 2000" is a registered trademark of the National Marine Electronics Association.

DSM150 *3.5" High Bright Color Display*

Maretron's DSM150 is a 3.5" high-resolution sunlight viewable color display that interprets and displays NMEA 2000® instrument, navigation, and vessel monitoring data. The DSM150 is a user friendly dedicated marine display with custom screen configurations and an easy-to-use five-key illuminated keypad. In addition to the monitoring and display capabilities, the DSM150 features an alert/ alarm package and electrical switching capability.

Unlike traditional single-display units, DSM150 users can choose numeric, gauge, bar or graph formats in single or multiple displays, with cycling options possible for a wide range of favorite data. These multiple display options conserve mounting space and reduce overall system cost.

The DSM150 will directly connect with any NMEA 2000® network and with the exception of AIS data will display any or all information captured throughout the vessel. Various audio and visual alarms are also programmable. The DSM150 displays a multitude of information including AC power, anchor status, battery, depth, electrical



distribution, engine, environment, fuel management, GPS, heading, navigation, pressure/vacuum, rudder, speed, status indicators, tanks, temperature, time, transmission, water makers, weather, wind and more.

Maretron's DSM150 is engineered and manufactured to the highest standards (IEC 60945 Maritime Navigation and Radiocommunication Equipment). Its compact waterproof housing will provide years of reliable performance. The DSM150 is available in a gray enclosure and includes a white sun cover and a one meter NMEA 2000® cable.

Products

PART NUMBER	DESCRIPTION
DSM150-02	3.5" High Bright Color Display (Gray Enclosure)
DSM150CVR-03	White DSM150 Cover
DSM150CABLE-01.0	DSM150 NMEA 2000® 1.0m Cable

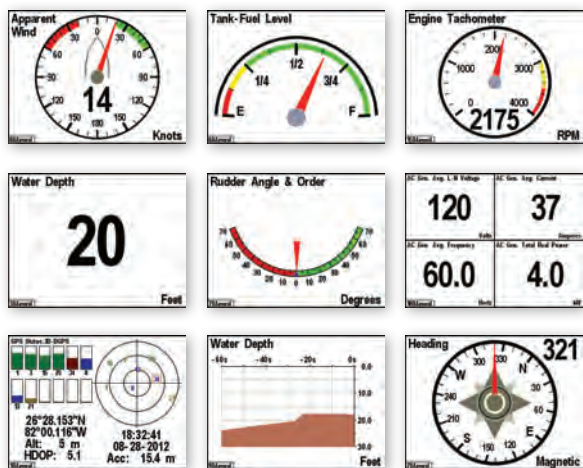
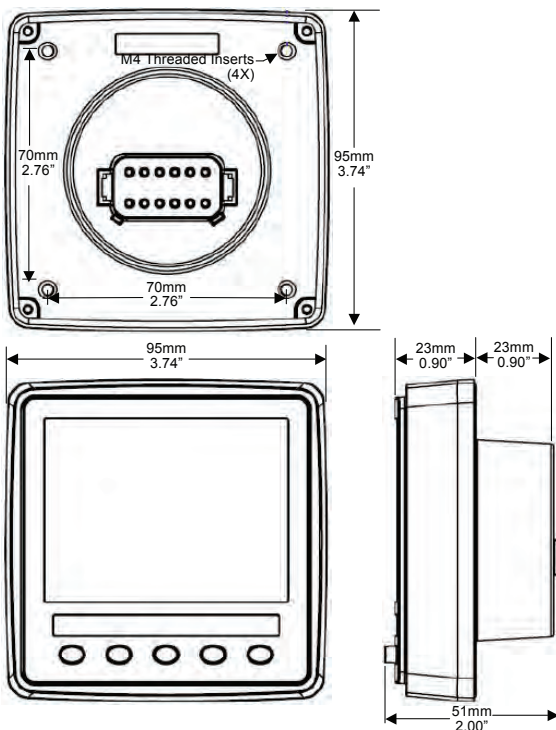

DSM150 Screen Shots



Copyright 2017 Maretron, LLP. All rights reserved. As Maretron is constantly improving its products, all specifications are subject to change without notice. Maretron's products are designed to be accurate and reliable; however, they should be used only as aids to navigation and vessel monitoring, and not as a replacement for traditional navigation and vessel monitoring techniques. A prudent captain or navigator never relies on a single source for navigation or system monitoring information. "NMEA 2000" is a registered trademark of the National Marine Electronics Association.

Certifications

Parameter	Value	Comment
NMEA 2000® Connector	DeviceNet Micro-C	With Included Adapter
Display Technology	Active Matrix TFT LCD	Sunlight Readable
Display Resolution	320 x 240 Pixels	QVGA Resolution
Display Viewable Area	70.07mm W x 52.56mm H	3.5" Diagonal
Display Brightness	800 Nits (cd/m ²)	
Display Backlighting	LED	3 User-Programmed Levels 0-100%
Keyboard	5 Silicone Rubber Keys	LED Backlighting
Languages Supported	English, Dutch (Nederlands)	User Selectable

Standard

Standard	Comment
NMEA 2000® Standard	Level A
Maritime Navigation and Radiocommunication Equipment & Systems	IEC 61162-3
Maritime Navigation and Radiocommunication Equipment & Systems	IEC 60945
FCC and CE Mark	Electromagnetic Compatibility

Supported Data Display Types

Instrument Type	Data Types
AC Power	Average Frequency, Average L-N Voltage, Average L-L Voltage, Phase A Frequency, Phase A L-N Voltage, Phase AB L-L Voltage, Phase B Frequency, Phase B L-N Voltage, Phase BC L-L Voltage, Phase C Frequency, Phase C L-N Voltage, Phase CA L-L Voltage,
Anchor	Watch
DC	Current, Voltage, Battery Temperature, Battery State of Charge, Battery Time Remaining, Ripple Voltage, Power
Depth	Water Depth, Water Below Transducer, Transducer Offset
Elec. Distribution	Switch/Breaker, Breaker Current
Engine Monitor	Boost Pressure, Hours, Coolant Pressure, Coolant Temp., Exhaust Gas Temp., Fuel Pressure, Fuel Rate, Oil Pressure, Oil Temp., Tachometer, Tilt/Trim, Voltage, Fuel Economy, Fuel Consumption, Percent Load, Percent Torque, Trip Fuel Used,
Environment	Barometer, Heat Index, Humidity Inside, Humidity Outside, Moon Phase, Sunrise, Sunset, Dew Point, Temp. Engine Room, Temp. Inside, Temp. Main Cabin, Temp. Outside, Temp. Sea, Twilight AM, Twilight PM, Weather, Wind Chill
Fuel Management	Distance to Empty, Time to Empty, Total Fuel Capacity, Total Fuel Level, Total Fuel Consumption, Total Trip Fuel Used, Total Fuel Economy, Total Fuel Rate, Total Fuel Remaining
GPS	COG, Lat/Lon, SOG, DOP, Satellites, Time, Accuracy
Heading	Heading, Rate of Turn, Variation
Humidity	Inside, Outside, User Defined
Indicator	Status
Navigation	BOD, BTW, COG, XTE, DTW, ETA, Lat/Lon, Rolling Road, Set/Drift, SOG, TTG, VMG, Waypoint Number & Name
Pressure/Vacuum	Water, Barometric, Compressed Air, Engine Boost, Engine Coolant, Engine Fuel, Engine Oil, Hydraulic Oil, Steam, Transmission Oil, User Defined
Rudder	Angle & Order
Speed	Through Water, Over Ground, Total Log, Trip Log
Tanks	Capacity, Level, Remaining
Temperature	Wind Chill, Bait Well, Battery, Engine Coolant, Engine Oil, Engine Room, Exhaust Gas, Freezer, Heat Index, Heating System, Inside, Live Well, Main Cabin, Outside, Refrigeration, Sea, Transmission Oil, User Defined
Time	Local Date, UTC Date, Moon Phase, Sunrise, Sunset, Local Time, UTC Time, Twilight AM, Twilight PM
Transmission	Gear, Oil Pressure, Oil Temperature
Vessel	Pitch, Roll, Trim Tabs, Keel
Watermaker	Sea Recovery Status Display
Wind	Apparent Direction and Speed, True Direction and Speed, Ground Direction and Speed

Electrical

Parameter	Value	Comment
Operating Voltage	8 to 32 Volts	DC Voltage
Power Consumption (Maximum)	150mA	
Load Equivalence Number (LEN)	3	NMEA 2000® Spec. (1LEN = 50 mA)
Reverse Battery Protection	Yes	Indefinitely
Load Dump Protection	Yes	Energy Rated per SAE J1113

Mechanical

Parameter	Value	Comment
Size	3.72" (H) x 3.72" (W) x 0.9" (Forward D) x 0.9" (Rear D) 95mm (H) x 95mm (W) x 23mm (Forward D) x 23mm (Rear D)	
Weight	5.6 oz. (160 g)	
Mounting	Flush Mount	

Environmental

Parameter	Value
IEC 60945 Classification	Exposed
Degree of Protection	IP67
Operating Temperature	-20°C to 70°C
Storage Temperature	-30°C to 80°C
Relative Humidity	93%RH @40° per IEC60945-8.2
Vibration	2-13.2Hz @ ±1mm, 13.2-100Hz @ 7m/s ² per IEC 60945-8.7
Rain and Spray	12.5mm Nozzle @ 100liters/min from 3m for 30min per IEC 60945-8.8
Solar Radiation	Ultraviolet B, A, Visible, and Infrared per IEC 60945-8.10
Corrosion (Salt Mist)	4 times 7 days @ 40°C, 95%RH after 2 hour Salt Spray Per IEC 60945-8.12
Electromagnetic Emission	Conducted and Radiated Emission per IEC60945-9
Electromagnetic Immunity	Conducted, Radiated, Supply, and ESD per IEC 60945-10
Safety Precautions	Dangerous Voltage, Electromagnetic Radio Frequency per IEC 60945-12

DSM250 *5.7" Multi-Function Color Display*



Maretron's DSM250 is a 5.7" high-resolution sunlight viewable color display that interprets and displays NMEA 2000® instrument, navigation, and vessel monitoring data. The DSM250 is a user friendly dedicated marine display with custom screen configurations and an easy-to-use five-key illuminated keypad. In addition to the monitoring and display capabilities, the DSM250 features an alert/ alarm package and electrical switching capability.

Unlike traditional single-display units, DSM250 users can choose numeric, gauge, bar or graph formats in single or multiple displays, with cycling options possible for a wide range of favorite data. These multiple display options conserve mounting space and reduce overall system cost.

The DSM250 will directly connect with any NMEA 2000® network and with the exception of AIS data will display any or all information captured throughout the vessel. Various audio and visual alarms are also programmable.

The DSM250 displays a multitude of information including AC power, anchor status, battery, depth, electrical distribution, engine, environment, fuel management, GPS, heading, navigation, pressure/ vacuum, rudder, speed, status indicators, tanks, temperature, time, transmission, water makers, weather, wind and more.

Maretron's DSM250 is engineered and manufactured to the highest standards (IEC 60945 Maritime Navigation and Radiocommunication Equipment). Its compact waterproof housing will provide years of reliable performance. The DSM250 is available in two different color cases including black and gray.

Products

PART NUMBER	DESCRIPTION
DSM250-01	High Bright Color Display (Black Enclosure)
DSM250-02	High Bright Color Display (Gray Enclosure)
DSMMNTASSBLY	DSM200/DSM250 Gimbal Mount
DSM250CVR2PK-01	Package of (2) Black DSM250 Covers
DSM250CVR2PK-02	Package of (2) Gray DSM250 Covers

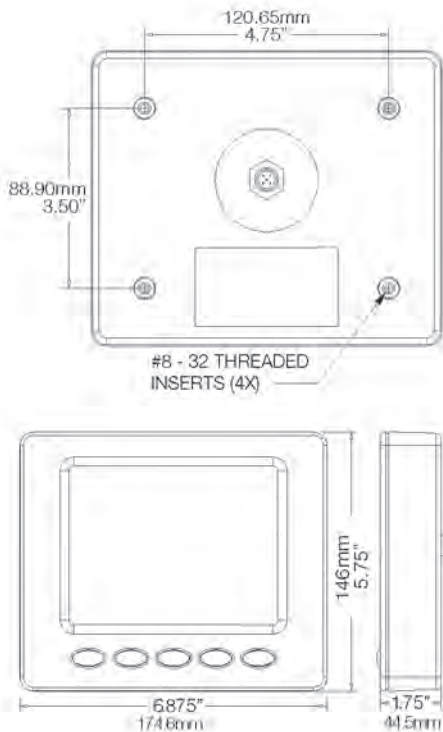

Flush Mount



Surface Mount



Gimbal Mount Helm



Gimbal Mount Ceiling



Copyright 2017 Maretron, LLP. All rights reserved. As Maretron is constantly improving its products, all specifications are subject to change without notice. Maretron's products are designed to be accurate and reliable; however, they should be used only as aids to navigation and vessel monitoring, and not as a replacement for traditional navigation and vessel monitoring techniques. A prudent captain or navigator never relies on a single source for navigation or system monitoring information. "NMEA 2000" is a registered trademark of the National Marine Electronics Association.

Specifications

Parameter	Value	Comment
NMEA 2000® Connector	DeviceNet Micro-C	Industry Standard Waterproof
Display Technology	Active Matrix TFT LCD	Sunlight Readable
Display Resolution	320 x 240 Pixels	QVGA Resolution
Display Viewable Area	117mm W x 88mm H	5.7" Diagonal
Display Backlighting	CCFL	3-User-Programmed Levels 0-100%
Keyboard	5 Silicone Rubber Keys	Multi-Colored LED Backlighting
Languages Supported	English, Dutch (Nederlands)	User Selectable

Certifications

Standard	Comment
NMEA 2000® Standard	Level A
Maritime Navigation and Radio Communication Equipment & Systems	IEC 61162-3
Maritime Navigation and Radio Communication Equipment & Systems	IEC 60945
FCC and CE mark	Electromagnetic Compatibility

Supported Data Display Types

Instrument Type	Data Types
AC Power	Average Frequency, Average L-N Voltage, Average L-L Voltage, Phase A Frequency, Phase A L-N Voltage, Phase AB L-L Voltage, Phase B Frequency, Phase B L-N Voltage, Phase BC L-L Voltage, Phase C Frequency, Phase C L-N Voltage, Phase CA L-L Voltage,
Anchor	Watch
DC	Current, Voltage, Battery Temperature, Battery State of Charge, Battery Time Remaining, Ripple Voltage, Power
Depth	Water Depth, Water Below Transducer, Transducer Offset
Elec. Distribution	Switch/Breaker, Breaker Current
Engine Monitor	Boost Pressure, Hours, Coolant Pressure, Coolant Temp., Exhaust Gas Temp., Fuel Pressure, Fuel Rate, Oil Pressure, Oil Temp., Tachometer, Tilt/Trim, Voltage, Fuel Economy, Fuel Consumption, Percent Load, Percent Torque, Trip Fuel Used,
Environment	Barometer, Heat Index, Humidity Inside, Humidity Outside, Moon Phase, Sunrise, Sunset, Dew Point, Temp. Engine Room, Temp. Inside, Temp. Main Cabin, Temp. Outside, Temp. Sea, Twilight AM, Twilight PM, Weather, Wind Chill
Fuel Management	Distance to Empty, Time to Empty, Total Fuel Capacity, Total Fuel Level, Total Fuel Consumption, Total Trip Fuel Used, Total Fuel Economy, Total Fuel Rate, Total Fuel Remaining
GPS	COG, Lat/Lon, SOG, DOP, Satellites, Time, Accuracy
Heading	Heading, Rate of Turn, Variation
Humidity	Inside, Outside, User Defined
Indicator	Status
Navigation	BOD, BTW, COG, XTE, DTW, ETA, Lat/Lon, Rolling Road, Set/Drift, SOG, TTG, VMG, Waypoint Number & Name
Pressure/Vacuum	Water, Barometric, Compressed Air, Engine Boost, Engine Coolant, Engine Fuel, Engine Oil, Hydraulic Oil, Steam, Transmission Oil, User Defined
Rudder	Angle & Order
Speed	Through Water, Over Ground, Total Log, Trip Log
Tanks	Capacity, Level, Remaining
Temperature	Wind Chill, Bait Well, Battery, Engine Coolant, Engine Oil, Engine Room, Exhaust Gas, Freezer, Heat Index, Heating System, Inside, Live Well, Main Cabin, Outside, Refrigeration, Sea, Transmission Oil, User Defined
Time	Local Date, UTC Date, Moon Phase, Sunrise, Sunset, Local Time, UTC Time, Twilight AM, Twilight PM
Transmission	Gear, Oil Pressure, Oil Temperature
Vessel	Pitch, Roll, Trim Tabs, Keel
Watermaker	Sea Recovery Status Display
Wind	Apparent Direction and Speed, True Direction and Speed, Ground Direction and Speed

Electrical

Parameter	Value	Comment
Operating Voltage	9 to 32 Volts	DC Voltage
Power Consumption (Maximum)	< 650mA	Low Supply, Full Brightness
	< 200mA	Nominal Supply, Low Brightness
Load Equivalence Number (LEN)	13	NMEA 2000® Spec. (1 LEN = 50mA)
Reverse Battery Protection	Yes	Indefinitely
Load Dump Protection	Yes	Energy Rated Per SAE J1113

Mechanical

Parameter	Value	Comment
Size	6.875" x 5.75" x 1.75" (174.6mm x 146mm x 44.5mm)	Including Flanges for Mounting
Weight	26 Oz. (737g)	
Mounting	Surface or Flush Mount	

Environmental

Parameter	Value
IEC 60945 Classification	Exposed
Degree of Protection	IP67
Operating Temperature	-25°C to 55°C
Storage Temperature	-40° to 70°C
Relative Humidity	93%RH @ 40°C per IEC 60945-8.2
Vibration	2-13.2Hz @ ±1mm, 13.2-100Hz @ 7m/s² per IEC 60945-8.7
Rain and Spray	12.5mm Nozzle @ 100liters/min from 3m for 30min per IEC 60945-8.8
Solar Radiation	Ultraviolet B, A, Visible, and Infrared per IEC 60945-8.10
Corrosion (Salt Mist)	4 times 7 days @ 40°C, 95%RH after 2 hour Salt Spray per IEC 60945-8.12
Electromagnetic Emission	Conducted and Radiated Emission per IEC60945-9
Electromagnetic Immunity	Conducted, Radiated, Supply, and ESD per IEC 60945-10
Safety Precautions	Dangerous Voltage, Electromagnetic Radio Frequency per IEC 60945-12

ALM100 *Alarm Module*

Maretron's Alarm Module generates visual and audible alerts for any monitored condition. The Alarm Module includes an extremely loud 105 dB SPL Piezoelectric sounder, along with a red high-brightness LED to indicate an alarm condition. A second green LED indicates that the Alarm Module is powered and ready to be triggered. The audible alarm can sound any one of 32 distinct pre-programmed patterns to indicate different alerts. The Alarm Module can be triggered by alarms generated by Maretron's N2KView® Vessel Monitoring System, or by Maretron's Color Graphics Displays (DSM150 or DSM250). The Alarm Module mounts in a standard electric box or can be flush mounted on any surface. Completely waterproof, the Alarm Module can be mounted inside or outside the vessel.



- NMEA 2000® Network Interface
- Super loud 105dB audible alarm
- Bright Red LED visual alarm
- Green LED status indicator
- Mounts in standard electrical wall box or flush mount directly in wall
- 32 selectable alarm patterns
- Waterproof - Can be mounted indoors or outdoors

Products

PART NUMBER	DESCRIPTION
ALM100-01	Alarm Buzzer with Black Cover Plate
CP-BK-ALM100	ALM100 Black Cover Plate
CP-WH-ALM100	ALM100 White Cover Plate

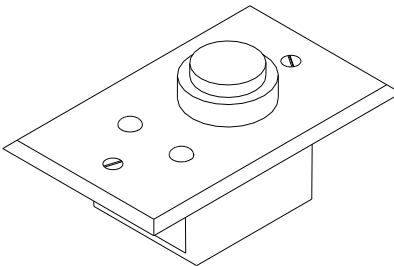
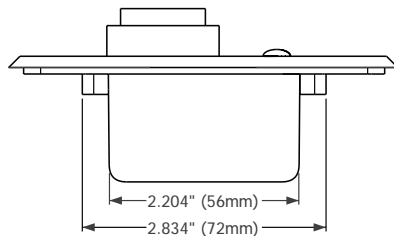
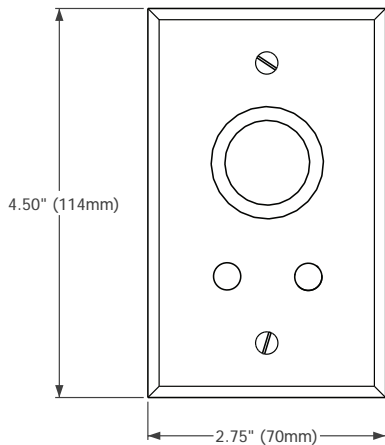

Specifications
Certifications

NMEA 2000® Parameter Group Numbers (PGNs)

Parameter	Value	Comment
Annunciator Volume	105 dB SPL	Mechanical Volume Control
Annunciator Frequency	2.9 kHz	

Standard	Comment
NMEA 2000® Standard	Level A
Maritime Navigation and Radio Communication Equipment & Systems	IEC 61162-3
Maritime Navigation and Radio Communication Equipment & Systems	IEC 60945
FCC and CE mark	Electromagnetic Compatibility

Description	PGN #	PGN Name	Default Rate
Periodic Data PGNs	128720	Proprietary Alarm Status	1 time/second
	126464	PGN List (Transmit and Receive)	N/A
	126996	Product Information	N/A
Response to Requested PGNs	126998	Configuration Information	N/A
	059392	ISO Acknowledge	N/A
	059904	ISO Request	N/A
Protocol PGNs	060928	ISO Address Claim	N/A
	065240	ISO Address Command	N/A
	126208	NMEA	N/A
	128720	Configuration	N/A
	Maretron Proprietary PGNs	128720	Configuration

Electrical

Parameter	Value	Comment
Operating Voltage	9 to 32 Volts	DC Voltage
Power Consumption	100 mA	NMEA 2000 Interface
Load Equivalence Number (LEN)	2	NMEA 2000® Spec. (1LEN = 50 mA)
Reverse Battery Protection	Yes	Indefinitely
Load Dump Protection	Yes	Energy Rated per SAE J1113

Mechanical

Parameter	Value	Comment
Size	2.75" x 4.50" x 2.00" (70mm x 114mm x 51mm)	Including wall plate – Mounts in standard single-gang electrical box
Weight	13 oz. (368.5g)	

Environmental

Parameter	Value
IEC 60945 Classification	Exposed
Degree of Protection	IP67
Operating Temperature	-25°C to 55°C
Storage Temperature	-40°C to 70°C
Relative Humidity	93%RH @40° per IEC60945-8.2
Vibration	2-13.2Hz @ ±1mm, 13.2-100Hz @ 7m/s² per IEC 60945-8.7
Rain and Spray	12.5mm Nozzle @ 100liters/min from 3m for 30min per IEC 60945-8.8
Solar Radiation	Ultraviolet B, A, Visible, and Infrared per IEC 60945-8.10
Corrosion (Salt Mist)	4 times 7days @ 40°C, 95%RH after 2 hour Salt Spray Per IEC 60945-8.12
Electromagnetic Emission	Conducted and Radiated Emission per IEC 60945-9
Electromagnetic Immunity	Conducted, Radiated, Supply, and ESD per IEC 60945-10
Safety Precautions	Dangerous Voltage, Electromagnetic Radio Frequency per IEC 60945-12

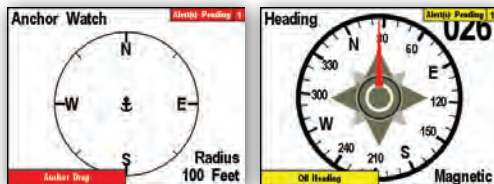

DSM150 & DSM250 Screen Shots



SMS100 *Short Message Service (Text) Module*

Maretron's SMS100 is a mobile or cellular modem that automatically sends text message alerts from your vessel to your phone. The SMS100 works together with Maretron's dedicated displays (DSM150/DSM250) or N2KView® software to detect programmable alert conditions from sensors interconnected on an NMEA 2000® network. The displays or N2KView® software instruct the SMS100 to connect to the cellular network and transmit an alert message to selected telephone numbers. Whether it is high bilge water, low battery voltage, unplugged shore power, or an opened hatch or door, the SMS100 quickly alerts you to conditions onboard your vessel that require attention anywhere you have cellular network coverage. You can also send a text message to your vessel, and with the proper sensors installed, the SMS100 will respond with status information including the vessel's position, bilge status, battery and shore power voltage, wind speed, inside and outside temperature.



- Programmable Alerts (Alarms or Warnings) from Maretron Installed Displays and Sensors on the Vessel Automatically Triggers Text Message(s) Sent to Your Phone
- User Can Text Vessel for Status (Position, Bilge Status, Battery and Shore Power Voltage, Wind Speed, Inside and Outside Temp) Which Also Double Checks Communication Path to Ensure Alerts Get Through
- Six Band GSM Modem with Easily Interchangeable mini-SIM Card (SIM Card is User Supplied)
- Dipole Terminal Antenna with Hinged SMA Connector with Versatile Mounting Options
- Waterproof (IP65) Enclosure

Products

PART NUMBER	DESCRIPTION
SMS100-01	SMS (Text) Module

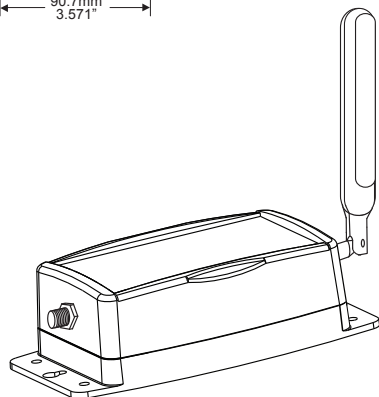
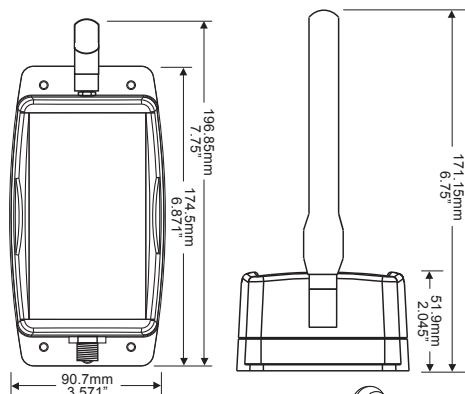

Alert Text



Status Text

NMEA 2000® Parameter Group Numbers (PGNs)

Specifications

Parameter	Value	Comment
NMEA 2000® Connector	DeviceNet Micro-C	Industry Standard Waterproof
NMEA 2000® Isolation	Opto-Isolated	Antenna Connector Isolated from NMEA 2000
Antenna Connector	SMA	For use only with supplied cellular antenna
Cellular Technologies	2G GSM/GPRS/EDGE 3G UMTS/HSDPA/HSUPA	
Supported Bands	800/850/900/1700/ 1900/2100 MHz	

Certifications

Parameter	Comment
NMEA 2000® Standard	Level A
Maritime Navigation and Radiocommunication Equipment & Systems	IEC 61162-3
Maritime Navigation and Radiocommunication Equipment & Systems	IEC 60945
FCC and R&TTE/CE Mark	Electromagnetic Compatibility
PTCRB	
AT&T	Network Ready

Electrical

Description	PGN #	PGN Name	Default Rate
Response to Requested PGNs	126464	PGN List (Transmit and Receive)	N/A
	126996	Product Information	N/A
	126998	Configuration Information	N/A
Protocol PGNs	059392	ISO Acknowledge	N/A
	059904	ISO Request	N/A
	060416	ISO Transport Protocol, Connection Management	N/A
	060160	ISO Transport Protocol, Data Transfer	N/A
	060928	ISO Address Claim	N/A
	065240	ISO Address Command	N/A
	126208	NMEA Request/Command/Acknowledge	N/A
Periodic PGNs	130834	SMS Status (Maretron Proprietary)	10 seconds
	130835	SMS Text Message (Maretron Proprietary)	On Receipt

Parameter	Value	Comment
Operating Voltage	9 to 32 Volts	DC Voltage
Power Consumption	<150mA	Average Current Drain
Load Equivalence Number (LEN)	3	NMEA 2000® Spec. (1LEN = 50 mA)
Reverse Battery Protection	Yes	Indefinitely
Load Dump Protection	Yes	Energy Rated per SAE J1113

Mechanical

Parameter	Value	Comment
Size	6.871" x 3.571" x 2.045" (174.5mm x 90.7mm x 51.9mm)	Including Flanges for Mounting
Weight	10.6 oz. (301 g)	

Environmental

Parameter	Value
IEC 60945 Classification	Exposed
Degree of Protection	IP65
Operating Temperature	-25°C to 55°C
Storage Temperature	-40°C to 85°C
Relative Humidity	93%RH @40° per IEC60945-8.2
Vibration	2-13.2Hz @ ±1mm, 13.2-100Hz @ 7m/s² per IEC 60945-8.7
Rain and Spray	12.5mm Nozzle @ 100liters/min from 3m for 30min per IEC 60945-8.8
Solar Radiation	Ultraviolet B, A, Visible, and Infrared per IEC 60945-8.10
Corrosion (Salt Mist)	4 times 7days @ 40°C, 95%RH after 2 hour Salt Spray Per IEC 60945-8.12
Electromagnetic Immunity	Conducted, Radiated, Fast Transient, Supply, and ESD per IEC 60945-10
Safety Precautions	Dangerous Voltage, Electromagnetic Radio Frequency per IEC 60945-12



NMEA 2000[®] Gateways and Bridges

USB100 – NMEA 2000[®] / USB Gateway

IPG100 – NMEA 2000[®] / Internet Protocol Gateway

J2K100 – NMEA 2000[®] / J1939 Gateway

NBE100 – Network Bus Extender (NMEA 2000[®] Bridge)

Although most of Maretron's vessel monitoring and control products are made to communicate across an NMEA 2000[®] network, there are times when it is appropriate to pass information over different communication protocols. Take for example the use of a computer or PC to monitor and control your vessel's systems. The PC doesn't have an NMEA 2000[®] connection, so a gateway like the Maretron USB100 is used to get information to and from the computer. In addition to gateway products, Maretron offers a bridge for interconnecting two NMEA 2000[®] networks (NBE100). This allows you to expand an NMEA 2000[®] network beyond the normal limitation of 50 products up to 100 or even 250 products. You can even use the NBE100 to build redundant networks where safety is of utmost importance.



USB100

NMEA 2000[®] / USB Gateway



IPG100

NMEA 2000[®] / Internet Protocol Gateway



J2K100

NMEA 2000[®] / J1939 Gateway



NBE100

Network Bus Extender (NMEA 2000[®] Bridge)



USB100 NMEA 2000® USB Gateway

Maretron's USB100 is a gateway for bridging computers to an NMEA network. This allows you to use PC based vessel monitoring and control software like Maretron's N2KView® or PC based navigation software. The gateway provides one simple connection between the network and the PC, which eliminates conventional multiplexers and the maze of wires usually associated with interfacing equipment to PCs.

For older PC based navigation software that requires receiving data in NMEA 0183 format, the USB100 automatically converts information from the NMEA 2000® network to NMEA 0183 sentences. You can continue benefiting from navigational and charting software that you already own while enjoying the many benefits of networked NMEA 2000® instruments.



Maretron's USB100 gateway is also used together with Maretron's N2KAnalyzer® software (see page 123), which allows you to use a PC for configuring, updating, and troubleshooting products connected to an NMEA 2000® network. You can even save all of the vessel's product configurations and easily restore them if a product needs to be replaced.

Products

PART NUMBER	DESCRIPTION
USB100-01	Gateway NMEA 2000® / USB

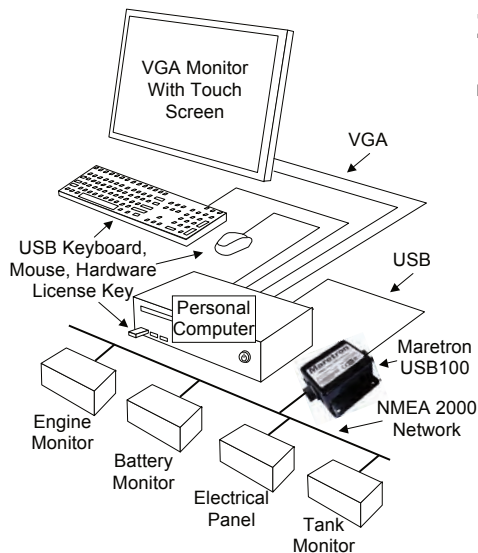
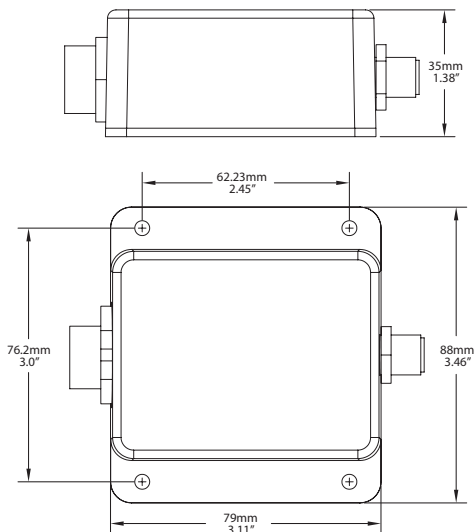

Specifications

Parameter	Value	Comment
NMEA 2000® Connector	DeviceNet Micro-C	Industry Standard Waterproof
NMEA 2000® / USB Isolation	Opto-Isolated	No Electrical Connection Across Bridge
USB Standard	USB 1.1	
USB Connector	USB Type B	Industry Standard Waterproof
USB Supported Signals	D+, D-, +5V, GND	Bi-directional Gateway
USB Auxiliary Power	+5 Volts < 50 mA	
USB Baud Rate	Up to 12 Mb/s	Full Speed USB Data Rate
USB Interface Modes	NMEA 0183	With Maretron-Supplied Windows® Drivers
	Native NMEA 2000®	For Use With N2KView and N2KAnalyzer
Supported Operating Systems	Windows XP, Vista, 7, and 8 (32-bit and 64-bit)	

Certifications

Standard	Comment
NMEA 2000® Standard	Level A
Maritime Navigation and Radio Communication Equipment & Systems	IEC 61162-3
Maritime Navigation and Radio Communication Equipment & Systems	IEC 60945
FCC and CE mark	Electromagnetic Compatibility

Translated Data Types (NMEA 2000® to NMEA 0183)

Instrument Type	Data Types
Battery Monitor	Voltage, Current, Temperature
Compass	Vessel Heading, Attitude, Rate of Turn
Depth	Water Depth, Transducer Offset
Engine	Standard Sentences: RPM, Proprietary Sentences: Boost Pressure, Tilt/Trim, Oil Pressure, Oil Temperature, Coolant Temperature, Alternator Potential, Fuel Rate, Total Engine Hours, Coolant Pressure, Fuel Pressure
GPS	COG, SOG, DOP, Position, Satellites, Time, Date
Rudder Indicator	Rudder Position
Speed	Distance Log, Speed
Weather Station	Water Temperature
Wind	Wind Direction and Speed

Electrical

Parameter	Value	Comment
Operating Voltage	9 to 16 Volts	DC Voltage
Power Consumption	< 150mA	Average Current Drain
Load Equivalence Number (LEN)	3	NMEA 2000® Spec. (1 LEN = 50mA)
Reverse Battery Protection	Yes	Indefinitely
Load Dump Protection	Yes	Energy Rated Per SAE J1113

Mechanical

Parameter	Value	Comment
Size	3.11" x 3.46" x 1.38" (79mm x 88mm x 35mm)	Including Flanges for Mounting
Weight	8 oz. (227 g)	

Environmental

Parameter	Value
IEC 60945 Classification	Exposed
Degree of Protection	IP67
Operating Temperature	-25°C to 55°C
Storage Temperature	-40°C to 70°C
Relative Humidity	93%RH @40° per IEC60945-8.2
Vibration	2-13.2Hz @ ±1mm, 13.2-100Hz @ 7m/s² per IEC 60945-8.7
Rain and Spray	12.5mm Nozzle @ 100liters/min from 3m for 30min per IEC 60945-8.8
Solar Radiation	Ultraviolet B, A, Visible, and Infrared per IEC 60945-8.10
Corrosion (Salt Mist)	4 times 7days @ 40°C, 95%RH after 2 hour Salt Spray Per IEC 60945-8.12
Electromagnetic Immunity	Conducted, Radiated, Supply, and ESD per IEC 60945-10
Safety Precautions	Dangerous Voltage, Electromagnetic Radio Frequency per IEC 60945-12



IPG100 *Internet Protocol Gateway*

The Internet Protocol Gateway (IPG100) lets you connect PC's, Mac's, tablets, or smartphones to an NMEA 2000® network so you can monitor and control your vessel using Maretron's N2KView® software or using Maretron's N2KView® Mobile app. The conventional way of viewing NMEA 2000® information on the vessel is with a display that is directly connected to an NMEA 2000® network, but with the IPG100, you are not limited to direct connected displays. With the IPG100, you can use devices running N2KView® software and the N2KView® Mobile app to monitor and control your vessel from onboard or ashore.

Products

PART NUMBER	DESCRIPTION
IPG100-01	Internet Protocol Gateway
PX0852	USB Waterproof Cover
PX0837/5M00	Waterproof Ethernet Cable 16.4'



The following accessories are available for the IPG100:



PX0852



PX0837/5M00

The IPG100 has an NMEA 2000® and an Ethernet data port for exchanging information between the onboard NMEA 2000® network and Internet Protocol (IP) enabled devices using conventional technology such as routers, switches, and wireless modems. Once enabled, the IPG100 will automatically connect to Maretron's Real Time Cloud Service (see page 12), which allows you to remotely connect to your vessel via the Internet. This allows you to keep an eye on your vessel from anywhere in the world.

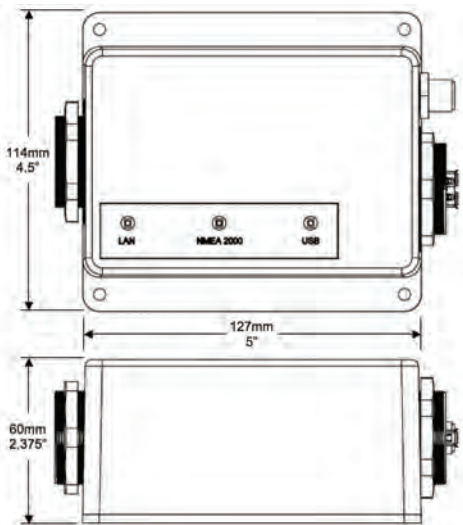

Multiple Wired and Wireless Devices Running N2KView[®] and N2KView[®] Mobile Vessel Monitoring and Control Software

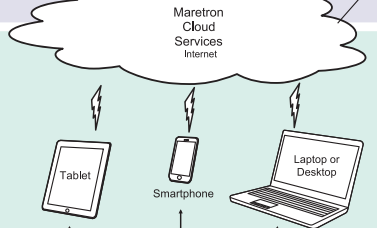
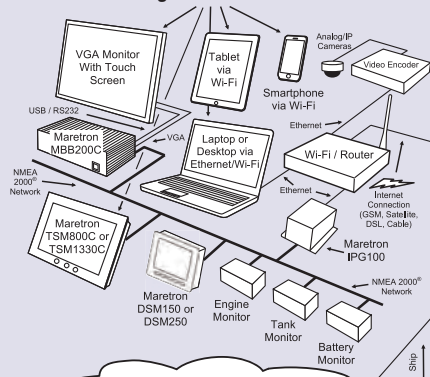

Remote Wired and Wireless Devices Running N2KView[®] and N2KView[®] Mobile

Specifications

Parameter	Value	Comment
NMEA 2000 [®] Connector	DeviceNet Micro-C	Industry Standard Waterproof
NMEA 2000 [®] Isolation	Opto-Isolated	No Electrical Connection Across Bridge
USB Standard	USB 1.1	
USB Connector	USB Type A	Industry Standard Waterproof, for Connection of N2KView Hardware License Key Only
USB Supported Signals	D+, D-, +5V, GND	Bi-directional Gateway
USB Auxiliary Power	+5 Volts < 200 mA	
USB Baud Rate	Up to 12 Mb/s	Full Speed USB Data Rate
Ethernet Interface	100 Mb/s	
Ethernet Connector	RJ-45	Industry Standard Waterproof

Certifications

Parameter	Comment
NMEA 2000 [®] Standard	Level A
Maritime Navigation and Radiocommunication Equipment & Systems	IEC 61162-3
Maritime Navigation and Radiocommunication Equipment & Systems	IEC 60945
FCC and CE Mark	Electromagnetic Compatibility

NMEA 2000[®] Parameter Group Numbers (PGNs)

Description	PGN #	PGN Name	Default Rate
Response to Requested PGNs	126464	PGN List (Transmit and Receive)	N/A
	126996	Product Information	N/A
	126998	Configuration Information	N/A
Protocol PGNs	059392	ISO Acknowledge	N/A
	059904	ISO Request	N/A
	060416	ISO Transport Protocol, Connection Management	N/A
	060160	ISO Transport Protocol, Data Transfer	N/A
	060928	ISO Address Claim	N/A
	065240	ISO Address Command	N/A
	126208	NMEA Request/Command/Acknowledge	N/A

Electrical

Parameter	Value	Comment
Operating Voltage	9 to 32 Volts	DC Voltage
Power Consumption	<150mA	Average Current Drain
Load Equivalence Number (LEN)	3	NMEA 2000 [®] Spec. (1LEN = 50 mA)
Reverse Battery Protection	Yes	Indefinitely
Load Dump Protection	Yes	Energy Rated per SAE J1113

Mechanical

Parameter	Value	Comment
Size	5.000" x 4.500" x 2.375" 127mm x 114mm x 60mm	Including Flanges for Mounting
Weight	12 oz. (340 g)	

Environmental

Parameter	Value
IEC 60945 Classification	Exposed
Degree of Protection	IP67
Operating Temperature	-25°C to 55°C
Storage Temperature	-40°C to 70°C
Relative Humidity	93%RH @40° per IEC60945-8.2
Vibration	2-13.2Hz @ ±1mm, 13.2-100Hz @ 7m/s ² per IEC 60945-8.7
Rain and Spray	12.5mm Nozzle @ 100liters/min from 3m for 30min per IEC 60945-8.8
Solar Radiation	Ultraviolet B, A, Visible, and Infrared per IEC 60945-8.10
Corrosion (Salt Mist)	4 times 7days @ 40°C, 95%RH after 2 hour Salt Spray Per IEC 60945-8.12
Electromagnetic Immunity	Conducted, Radiated, Supply, and ESD per IEC 60945-10
Safety Precautions	Dangerous Voltage, Electromagnetic Radio Frequency per IEC 60945-12



J2K100 *J1939 to NMEA 2000® Gateway*

Maretron's J2K100 attaches directly into J1939 networks of compatible engines, transmissions, and gensets and converts the J1939 data to the marine digital interface (NMEA 2000®). Critical engine, transmission, and genset data is then distributed throughout the vessel over a single cable where it can be monitored by any NMEA 2000® compatible display.

The J2K100 can also be used as part of a complete fuel computer. Simply connect the J2K100 together with Maretron universal displays (DSM150, DSM250, N2KView) and GPS antenna/receiver (GPS200) and you have a system capable of displaying gallons per hour and/or miles per gallon.



Products

PART NUMBER	DESCRIPTION
J2K100-01	J1939 to NMEA 2000® Gateway
MCF-2M-D4	J2K100 adapter Micro female to Deutsch 4 Pin 2 Meter Cordset
MCF-2M-D12	J2K100 adapter Micro female to Deutsch 12 Pin 2 Meter Cordset
MCF-2M-D12CAT	J2K100 adapter Micro female to Deutsch 12 Pin 2 T cable

The J2K100 converts the following information:

- AC Generator Current
- AC Generator Frequency
- AC Generator Voltage
- Tachometer
- Engine Hours
- Coolant Pressure
- Coolant Water Temperature
- Engine Oil Pressure
- Engine Oil Temperature
- Boost Pressure
- Fuel Rate Monitoring
- Charging Voltage
- Percent Engine Load
- Percent Engine Torque
- Rated Engine Speed
- VIN
- Software ID
- Transmission Gear
- Transmission Oil Pressure
- Transmission Oil Temperature



The J2K100 is compatible with any engine, transmission, or genset equipped with a J1939 interface, including products from the following manufacturers:

- Caterpillar
- Cummins
- Detroit Diesel
- John Deere
- Kohler
- Northern Lights
- Onan
- Perkins
- Steyr
- Volvo Penta
- Yanmar

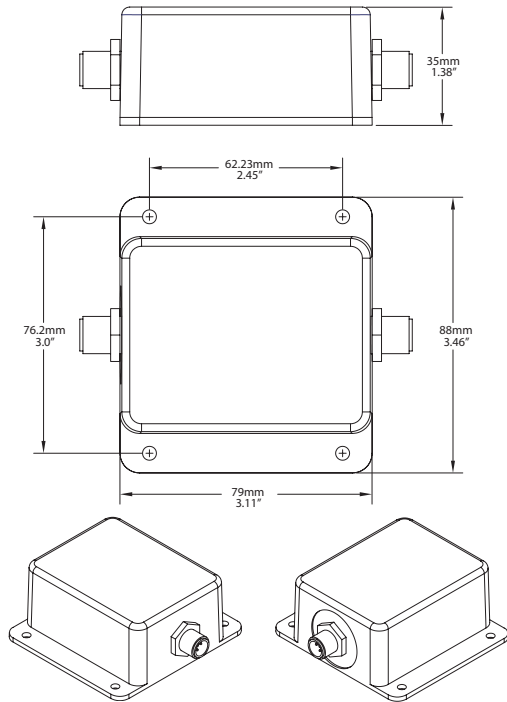

N2KView Engine Screen

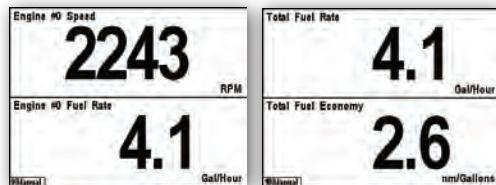

DSM150 & DSM250 Screen Shots

Specifications (J1939 Data Translated to NMEA 2000® Data)

J1939 SPN/PGN	Description	NMEA 2000® PGN
190 / 61444	Engine Speed	127488
102 / 65270	Engine Turbocharger Boost Pressure	127488
100 / 65263	Engine Oil Pressure	127489
175 / 65262	Engine Oil Temperature 1	127489
110 / 65262	Engine Coolant Temperature	127489
167 / 65271	Alternator Potential (Voltage)	127489
183 / 65266	Engine Fuel Rate	127489
247 / 65253	Engine Total Hours of Operation	127489
109 / 65263	Engine Coolant Pressure	127489
94 / 65263	Engine Fuel Delivery Pressure	127489
92 / 61443	Engine Percent Load at Current Speed	127489
513 / 61444	Actual Engine – Percent Torque	127489
189 / 65214	Engine Rated Speed	127498
237 / 65260	Vehicle Identification Number	127498
234 / 65242	Software Identification	127498
523 / 61445	Transmission Current Gear	127493
127 / 65272	Transmission Oil Pressure	127493
177 / 65272	Transmission Oil Temperature	127493

Certifications

Standard	Comment
NMEA 2000® Standard	Level B+
Maritime Navigation and Radio Communication Equipment & Systems	IEC 61162-3
Maritime Navigation and Radio Communication Equipment & Systems	IEC 60945
FCC and CE mark	Electromagnetic Compatibility

NMEA 2000® Parameter Group Numbers (PGNs)

Description	PGN #	PGN Name	Default Rate
Periodic Data PGNs	127488	Engine Parameters, Rapid Update	10 times/second
	127489	Engine Parameters, Dynamic	1 time/second
	127498	Engine Parameters, Static	N/A
	127493	Transmission Parameters, Dynamic	10 times/second
	65030	J1939 Generator Average Basic AC Quantities	10 times/second
	65226	J1939 Diagnostic Message #1	N/A
	65227	J1939 Diagnostic Message #2	N/A
	65228	J1939 Diagnostic Message #3	N/A
	65229	J1939 Diagnostic Message #4	N/A
	65230	J1939 Diagnostic Message #5	N/A
	65231	J1939 Diagnostic Message #6	N/A
	65232	J1939 Diagnostic Message #8	N/A
Response to Request PGNs	65234	J1939 Diagnostic Message #10	N/A
	65235	J1939 Diagnostic Message #11	N/A
	65236	J1939 Diagnostic Message #12	N/A
	126464	PGN List (Transmit and Receive)	N/A
Protocol PGNs	126996	Product Information	N/A
	126998	Configuration Information	N/A
Maretron Proprietary PGNs	059392	ISO Acknowledge	N/A
	059904	ISO Request	N/A
	060928	ISO Address Claim	N/A
	065240	ISO Address Command	N/A
	126208	NMEA Request/Command/Acknowledge	N/A
126720	Configuration	N/A	

Mechanical Electrical

Parameter	Value	Comment
Operating Voltage	9 to 16 Volts	DC Voltage
Power Consumption	<150mA	Average Current Drain
Load Equivalence Number (LEN)	3	NMEA 2000® Spec. (1LEN = 50 mA)
Reverse Battery Protection	Yes	Indefinitely
Load Dump Protection	Yes	Energy Rated per SAE J1113

Environmental

Parameter	Value	Comment
Size	3.11" x 3.46" x 1.38" (79mm x 88mm x 35mm)	Including Flanges For Mounting
Weight	8 oz. (227 g)	
IEC 60945 Classification	Exposed	
Degree of Protection	IP67	
Operating Temperature	-25°C to 55°C	
Storage Temperature	-40°C to 70°C	
Relative Humidity	93%RH @40° per IEC60945-8.2	
Vibration	2-13.2Hz @ ±1mm, 13.2-100Hz @ 7ms ² per IEC 60945-8.7	
Rain and Spray	12.5mm Nozzle @ 100liters/min from 3m for 30min per IEC 60945-8.8	
Solar Radiation	Ultraviolet B, A, Visible, and Infrared per IEC 60945-8.10	
Corrosion (Salt Mist)	4 times 7days @ 40°C, 95%RH after 2 hour Salt Spray Per IEC 60945-8.12	
Electromagnetic Emission	Conducted and Radiated Emission per IEC 60945-9	
Electromagnetic Immunity	Conducted, Radiated, Supply, and ESD per IEC 60945-10	
Safety Precautions	Dangerous Voltage, Electromagnetic Radio Frequency per IEC 60945-12	



NBE100 *Network Bus Extender*

Maretron's NBE100 allows you to go beyond the maximum NMEA 2000® network design rules and extend an NMEA 2000® network to two, three, four, and even five times larger than normal. The NBE100 also solves problems associated with network errors and other electrical issues caused by exceeding NMEA 2000® rules and it simplifies the design of large networks.

NMEA 2000® network rules allow a maximum of 50 products connected on a single network, a maximum trunk length of 200 meters, and a maximum drop length of 78 meters. If you have a network that exceeds any of these specifications, you can simply extend the network trunk by inserting the NBE100, along with the additional termination resistors and powertaps. This will split the network into multiple electrical segments allowing 50 products per segment. The NBE100 will transparently route NMEA 2000® messages between multiple network segments, making them work as a single logical NMEA 2000® network.

Lastly, the NBE100 can be used to build redundant networks or isolate certain network segments so that if one segment is compromised, the other segments continue to operate.



- Segments a single large NMEA 2000® network into smaller multiple electrical segments.
- Allows you to exceed the 50 product limitation on a NMEA 2000® network.
- Allows you to exceed the 200 meter trunk length limitation on a NMEA 2000® network.
- Allows you to exceed the 78 meter drop lengths limitation on a NMEA 2000® networks.
- Allows all NMEA 2000® devices to operate as if they were still on a single NMEA 2000® network.
- Optically isolates network segments, increasing signal integrity and network reliability.

Products

PART NUMBER	DESCRIPTION
NBE100-01	NMEA 2000® Network Bus Extender

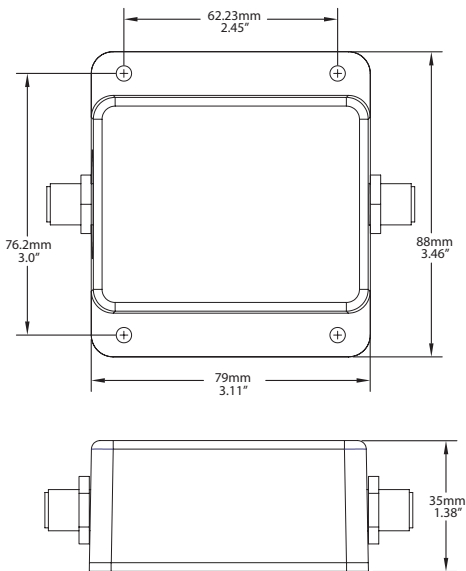

Certifications

Parameter	Comment
NMEA 2000® Standard	Level A
Maritime Navigation and Radiocommunication Equipment & Systems	IEC 61162-3
Maritime Navigation and Radiocommunication Equipment & Systems	IEC 60945
FCC and CE Mark	Electromagnetic Compatibility

NMEA 2000® Parameter Group Numbers (PGNs)

Description	PGN #	PGN Name	Default Rate
Response to Requested PGNs	126464	PGN List (Transmit and Receive)	N/A
	126996	Product Information	N/A
	126998	Configuration Information	N/A
Protocol PGNs	059392	ISO Acknowledge	N/A
	059904	ISO Request	N/A
	060928	ISO Address Claim	N/A
	065240	ISO Address Command	N/A
	126208	NMEA Request/Command/Acknowledge	N/A
Maretron Proprietary PGNs	126720	Configuration	N/A

Electrical

Parameter	Value	Comment
Operating Voltage	9 to 16 Volts	DC Voltage
Power Consumption	<150mA	Average Current Drain
Load Equivalence Number (LEN)	3	NMEA 2000® Spec. (1LEN = 50 mA)
Reverse Battery Protection	Yes	Indefinitely
Load Dump Protection	Yes	Energy Rated per SAE J1113

Network Extension Side-to-Side Example

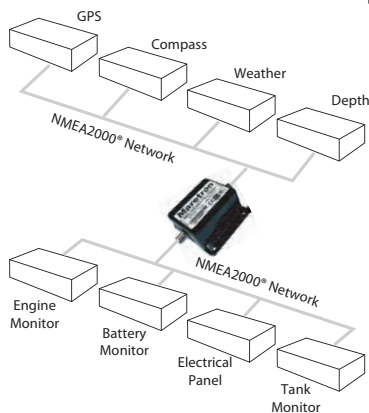

Mechanical

Parameter	Value	Comment
Size	3.11" x 3.46" x 1.38" (79mm x 88mm x 35mm)	Including Flanges for Mounting
Weight	8 oz. (227 g)	

Environmental

Parameter	Value
IEC 60945 Classification	Exposed
Degree of Protection	IP67
Operating Temperature	-25°C to 55°C
Storage Temperature	-40°C to 70°C
Relative Humidity	93%RH @40° per IEC60945-8.2
Vibration	2-13.2Hz @ ±1mm, 13.2-100Hz @ 7m/s ² per IEC 60945-8.7
Rain and Spray	12.5mm Nozzle @ 100liters/min from 3m for 30min per IEC 60945-8.8
Solar Radiation	Ultraviolet B, A, Visible, and Infrared per IEC 60945-8.10
Corrosion (Salt Mist)	4 times 7 days @ 40°C, 95%RH after 2 hour Salt Spray Per IEC 60945-8.12
Electromagnetic Emission	Conducted and Radiated Emission per IEC 60945-9
Electromagnetic Immunity	Conducted, Radiated, Supply, and ESD per IEC 60945-10
Safety Precautions	Dangerous Voltage, Electromagnetic Radio Frequency per IEC 60945-12

Network Extension End-to-End Example

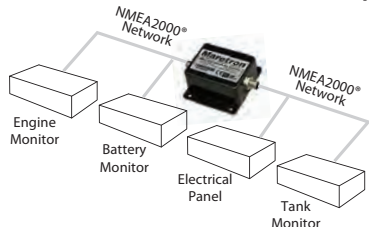

Tank Monitoring

FPM100 – *Fluid Pressure Monitor*

TLM100 – *Tank Level Monitor (Max 40" Depth)*

TLM150 – *Tank Level Monitor (Gasoline)*

TLM200 – *Tank Level Monitor (Max 104" Depth)*

TLA100 – *Tank Level Adapter*

When it comes to tank monitoring, Maretron offers the most comprehensive NMEA 2000® technology in the industry. Whether you are looking to retrofit a tank with an existing resistive sensor, or if you're interested in precision tank level even when heeled over during sailing or riding bow up on plane, Maretron offers the right product for the application. All of Maretron's tank monitors can be custom calibrated for odd shaped tanks providing unprecedented accuracy, especially when compared to older analog gauge technologies. Maretron's tank monitors can even be programmed with the tank capacity so that multiple tanks can be combined into a single total tank gauge for display. You no longer have to mentally add up multiple tanks to figure how much water or fuel is onboard. And a real plus is that Maretron's user interface products will combine information from the tank monitors, fuel flow monitors, and GPS speed information to provide you with trip parameters like distance and time to empty. So look to Maretron for the widest variety of tank monitoring products and features in the industry.



FPM100
Fluid Pressure Monitor





TLM100

Tank Level Monitor (Max 40" Depth)



TLM150

Tank Level Monitor (Gasoline)



TLM200

Tank Level Monitor (Max 104" Depth)



TLA100

Tank Level Adapter



FPM100 *Fluid Pressure Monitor*

Maretron's Fluid Pressure Monitor is used to adapt up to six pressure transducers to the NMEA 2000® network (pressure transducers sold separately). This allows you to observe fluid pressures and tank levels anywhere on the vessel where there are NMEA 2000® compatible displays. With the appropriate transducer, the FPM100 reports either pressure or vacuum for a variety of applications including water pressures, oil pressures, hydraulic pressures, or system vacuum for detecting clogged filters.

The FPM100 also has a tank level mode, so that fluid levels in a tank can be monitored via a pressure transducer mounted at the bottom of the tank and transmitted over the NMEA 2000® network. This allows you to monitor the fluid levels in tanks that are extremely deep, have internal structures, or are otherwise not suited for other tank level sensing technologies. In this mode, the FPM100 can be calibrated for irregular tank shapes so that you know the true level of the tanks.



The following accessories are available for the FPM100:



PT-0-xxxxPSI-01



PT-SNUB-01



PTS-0-x.xPSI-01



The Maretron FPM100 has the following features:

- NMEA 2000® interface
- Adapts up to six pressure transducers to the NMEA 2000® network
- Each channel independently programmable to match pressure transducer characteristics
- Each channel independently programmable in pressure/vacuum mode or tank level mode

Products

PART NUMBER	DESCRIPTION
FPM100-01	Fluid Pressure Monitor
PT-0-3PSI-01	Pressure Transducer 0 to 3 PSI
PT-0-5PSI-01	Pressure Transducer 0 to 5 PSI
PT-0-10PSI-01	Pressure Transducer 0 to 10 PSI
PT-0-50PSI-01	Pressure Transducer 0 to 50 PSI
PT-0-100PSI-01	Pressure Transducer 0 to 100 PSI
PT-0-300PSI-01	Pressure Transducer 0 to 300 PSI
PT-0-500PSI-01	Pressure Transducer 0 to 500 PSI
PT-0-1000PSI-01	Pressure Transducer 0 to 1000 PSI
PT-0-3000PSI-01	Pressure Transducer 0 to 3000 PSI
PT-0-5000PSI-01	Pressure Transducer 0 to 5000 PSI
PT-SNUB-01	Pressure Snubber
PT-V-0-1BAR-01	Pressure Transducer Vacuum to 1 Bar
PTS-0-1.5PSI-01	Submersible Pressure Transducer 0 to 1.5 PSI
PTS-0-3.0PSI-01	Submersible Pressure Transducer 0 to 3.0 PSI

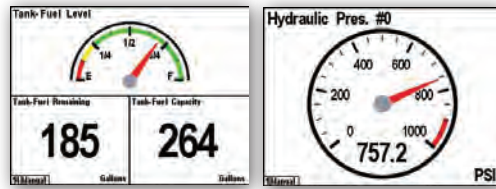
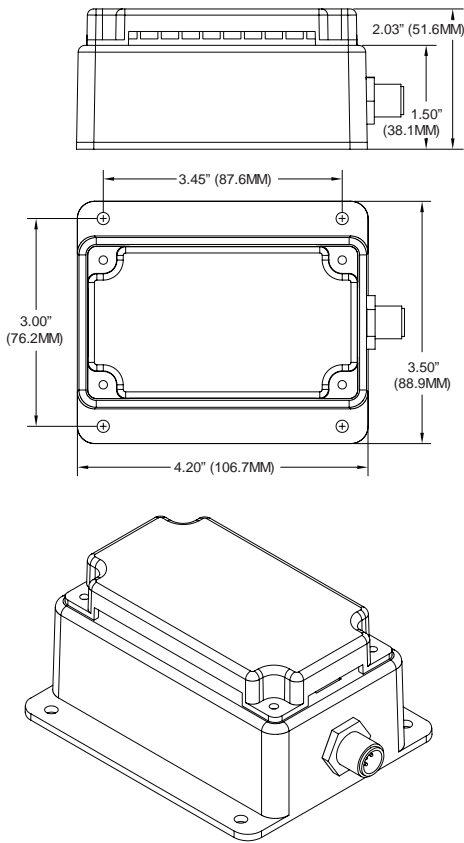

DSM150 & DSM250 Screen Shots

**Specifications
(Pressure/
Vacuum Mode)**

Parameter	Value	Comment
Accuracy	+/-1% FS	Exclusive of Pressure Transducer
Resolution	+/-0.33% FS	Over Full Pressure Transducer Range
Number of Pressure Source Types	21	Water Pressure, Atmospheric Pressure, Compressed Air Pressure, Hydraulic Pressure, Steam Pressure, 16 User Defined Sources

**Specifications
(Tank Level Mode)**

Parameter	Value	Comment
Accuracy	+/-1% FS	Exclusive of Pressure Transducer
Resolution	+/-0.33% FS	Over Full Pressure Transducer Range
Number of Tank Types	16	Fuel, Fresh Water, Waste water, Live well, Oil, etc.
Number of Tanks per Tank Type	16	16 Tanks per Tank Type Numbered 0-15
Support for Irregularly Shaped Tanks	Yes	Can be Calibrated for any Shape Tank
Programmable Tank Capacity	Yes	Allows Displays to Calculate Amount Remaining
Support for Irregularly Shaped Tanks	Yes	Can be Calibrated for any Shape Tank
Programmable Tank Capacity	Yes	Allows Displays to Calculate Amount Remaining

Certifications

Standard	Comment
NMEA 2000	Level A
Maritime Navigation and Radiocommunication Equipment & Systems	IEC 61162-3
Maritime Navigation and Radiocommunication Equipment & Systems	Tested to IEC 60945
FCC and CE Mark	Electromagnetic Compatibility

**NMEA 2000® Parameter
Group Numbers (PGNs) See
Appendix A for Details**

Description	PGN #	PGN Name	Default Rate
Periodic Data PGNs	127505	Fluid Level	0.4 Times/Second
	130314	Actual Pressure	0.5 Times/Second
Response to Requested PGNs	126464	PGN List (Transmit and Receive)	N/A
	126996	Product Information	N/A
	126998	Configuration Information	N/A
Protocol PGNs	059392	ISO Acknowledge	N/A
	059904	ISO Request	N/A
	060928	ISO Address Claim	N/A
	065240	ISO Address Command	N/A
	126208	NMEA	N/A
Maretron Proprietary PGNs	128720	Configuration	N/A

Electrical

Parameter	Value	Comment
Operating Voltage	9 to 32 Volts	DC Voltage
Power Consumption	400mA	Maximum Current Drain
Load Equivalence Number (LEN)	8	NMEA 2000® Spec. (1LEN = 50mA)
Reverse Battery Protection	Yes	Indefinitely
Load Dump Protection	Yes	Energy Rated per SAE J1113

Mechanical

Parameter	Value	Comment
Size	3.50" x 4.20" x 2.03" (88.9mm x 106.7mm x 51.6mm)	Including Flanges for Mounting
Weight	13 oz. (368.5 g)	

Environmental

Parameter	Value
IEC 60945 Classification	Exposed
Degree of Protection	IP64
Operating Temperature	-25°C to 55°C
Storage Temperature	-40°C to 70°C
Relative Humidity	93%RH @40° per IEC60945-8.2
Vibration	2-13.2Hz @ ±1mm, 13.2-100Hz @ 7m/s² per IEC 60945-8.7
Solar Radiation	Ultraviolet B, A, Visible, and Infrared per IEC 60945-8.10
Corrosion (Salt Mist)	4 times 7days @ 40°C, 95%RH after 2 hour Salt Spray Per IEC 60945-8.12
Electromagnetic Emission	Conducted and Radiated Emission per IEC 60945-9
Electromagnetic Immunity	Conducted, Radiated, Supply, and ESD per IEC 60945-10
Safety Precautions	Dangerous Voltage, Electromagnetic Radio Frequency per IEC 60945-12



TLM100 Tank Level Monitor (40" Depth)

Maretron's TLM100 is used to sense fluid levels of tanks by using ultrasonic technology. Ultrasonic, or sound waves, are transmitted via the TLM100 mounted at the top of the tank and the flight times of the sound waves to and from the fluid are measured much like a depth sensor. What this means for you is that there are no difficult to handle long probes protruding into the tank, which often foul and/or corrode. Once the TLM100 calculates and transmits the fluid level over the NMEA 2000® network, you can observe tank levels anywhere on the vessel where there is an NMEA 2000® compatible display such as the Maretron DSM150 or DSM250.

The TLM100 is capable of sensing fluid levels in tanks up to 40" (1.02m) in depth. It can be used for diesel, fresh water, waste water, black water, and oil tanks (see TLM150 for gasoline tanks or TLM200 for deeper tanks). Unlike most tank senders that only work with rectangular tanks, the TLM100 can be calibrated for irregular tank shapes so you can know the true fluid level in your tanks.



The TLM100 is mounted directly to the top of tanks using the industry standard SAE J1810 5-hole mounting pattern. The TLM100 can also be mounted to tanks with threaded tank openings using optional adapters that included both a 1.5" NPT and a 1.25" BSP adapter. There are other important TLM100 optional accessories including an optional focus tube to permit use on boats with planing hulls, which is required if the vessel spends a significant amount of time with the bow pitched up.

Most importantly, the TLM100 is NMEA 2000® certified so you can view any and all tank levels anywhere on the vessel when using a compatible NMEA 2000® display. The TLM100 is another key component of Maretron's N2KView® vessel monitoring and control system.

Products

PART NUMBER	DESCRIPTION
TLM100-01	Tank Level Monitor (40" Depth Tanks)
TA-5H-1.25BSP	1.25" BSP Displacement Hull Tank Adapter
TA-5H-1.5NPT	1.5" NPT Displacement Hull Tank Adapter
TFT-5H	SAE 5-Bolt Pattern Non-Displacement Hull Focus Tube
TFT-1.25BSP	1.25" BSP Non-Displacement Hull Focus Tube
TFT-1.5NPT	1.5" NPT Non-Displacement Hull Focus Tube
TFTDBE-5H SAE	5-Bolt Pattern Focus Tube with Dead Band Eliminator

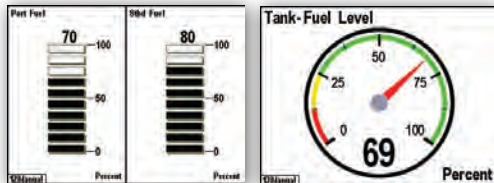
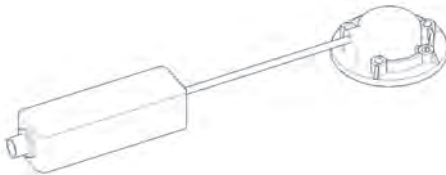
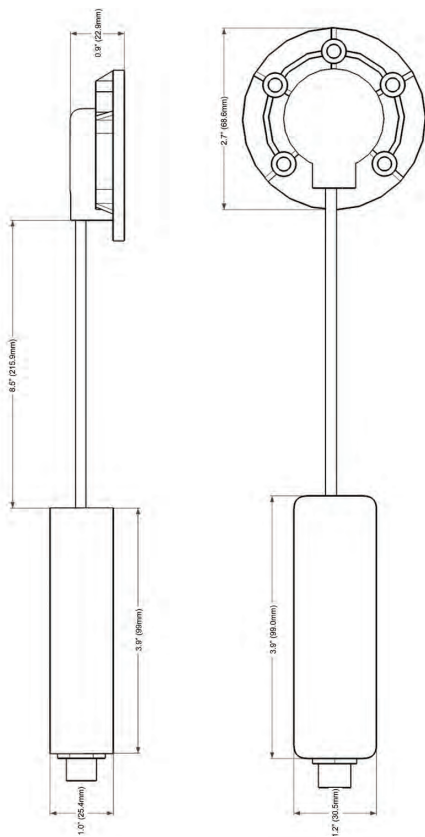

DSM150 & DSM250 Screen Shots

Specifications

Parameter	Value	Comment
Accuracy	+/-2%	
Resolution	+/-1%	
Number of Tank Types	16	Fuel, Fresh Water, Waste Water, Live well, Oil, etc.
Number of Tanks per Tank Type	16	16 Tanks per Tank Type Numbered 0-15
Maximum Tank Depth	40" (1.02m)	
Minimum Depth Reading	2" (5.08cm)	Sensor Deadband
Support for Irregularly Shaped Tanks	Yes	Can be Calibrated for any Shape Tank
Programmable Tank Capacity	Yes	Allows Displays to Calculate Amount Remaining
Maximum Tank Angle	6°	Without focus tube
	15°	With focus tube

Certifications

Standard	Comment
NMEA 2000	Level B
Maritime Navigation and Radio Communication Equipment & Systems	Tested to IEC 60945
FCC and CE mark	Electromagnetic Compatibility

NMEA 2000® Parameter Group Numbers (PGNs)

Description	PGN #	PGN Name	Default Rate
Periodic Data PGNs	127505	Fluid Level	0.4 times/second
Response to Requested PGNs	126464	PGN List (Transmit and Receive)	N/A
	126996	Product Information	N/A
	126998	Configuration Information	N/A
Protocol PGNs	059392	ISO Acknowledge	N/A
	059904	ISO Request	N/A
	060928	ISO Address Claim	N/A
	065240	ISO Address Command	N/A
	126208	NMEA	N/A

Electrical

Parameter	Value	Comment
Operating Voltage	9 to 16 Volts	DC Voltage
Power Consumption	<100mA	Average Current Drain
Load Equivalence Number (LEN)	2	NMEA 2000® Spec. (1LEN = 50mA)
Reverse Battery Protection	Yes	Indefinitely
Load Dump Protection	Yes	Energy Rated per SAE J1113

Mechanical

Parameter	Value	Comment
Size	3.9" x 1.2" x 1.0" (99mm x 30.5mm x 25.4mm)	Interface Component
	2.7" dia. X 0.9" (68.6mm dia. x 22.9mm)	Sensor Component
	8.5" (215.9mm)	Interconnecting Cable
Weight	12 oz. (340g)	
Mounting	SAE J1810 5-hole bolt pattern	Can mount to 1.25" BSP or 1.5" NPT using available adapters

Environmental

Parameter	Value
IEC 60945 Classification	Exposed
Degree of Protection	IP67
Operating Temperature	-25°C to 55°C
Storage Temperature	-40°C to 70°C
Relative Humidity	93%RH @40° per IEC60945-8.2
Vibration	2-13.2Hz @ ±1mm, 13.2-100Hz @ 7m/s² per IEC 60945-8.7
Rain and Spray	12.5mm Nozzle @ 100liters/min from 3m for 30min per IEC 60945-8.8
Solar Radiation	Ultraviolet B, A, Visible, and Infrared per IEC 60945-8.10
Corrosion (Salt Mist)	4 times 7days @ 40°C, 95%RH after 2 hour Salt Spray Per IEC 60945-8.12
Electromagnetic Emission	Conducted and Radiated Emission per IEC 60945-9
Electromagnetic Immunity	Conducted, Radiated, Supply, and ESD per IEC 60945-10
Safety Precautions	Dangerous Voltage, Electromagnetic Radio Frequency per IEC 60945-12



TLM150 Tank Level Monitor (Gasoline)

Maretron's TLM150 is used to sense gasoline fluid levels of tanks using ultrasonic technology. Ultrasonic, or sound waves, are transmitted via the TLM150 mounted at the top of the tank and the flight times of the sound waves to and from the fluid are measured much like a depth sensor. What this means for you is that there are no difficult to handle long probes protruding into the tank, which often foul and/or corrode. Once the TLM150 calculates and broadcast the fluid level over the NMEA 2000® network, you can observe tank levels anywhere on the vessel where there is an NMEA 2000® compatible display such as the Maretron DSM150 or DSM250.

The TLM150 is capable of sensing gasoline levels in tanks up to 24" (0.61m) in depth (see TLM100 for fluid types other than gasoline in tanks up to 40" or the TLM200 for tanks up to 104"). Unlike most tank senders that only work with rectangular tanks, the TLM150 can be calibrated for irregular tank shapes so you can know the true fluid level in your tanks.



The TLM150 is mounted directly to the top of tanks using the industry standard SAE J1810 5-hole mounting pattern. The TLM150 can also be mounted to tanks with threaded tank openings using optional adapters that include both a 1.5" NPT and a 1.25" BSP adapter. The other important optional accessory for the TLM150 is the focus tube to permit use on boats with planing hulls, which is required if the vessel spends a significant amount of time with the bow pitched up.

Most importantly, the TLM150 is NMEA 2000® certified so you can view any and all tank levels anywhere on the vessel when using a compatible NMEA 2000® display. The TLM150 is another key component of Maretron's N2KView® vessel monitoring and control system.

Products

PART NUMBER	DESCRIPTION
TLM150-01	Tank Level Monitor (24" Depth Gasoline Tanks)
TA-5H-1.25BSP	1.25" BSP Displacement Hull Tank Adapter
TA-5H-1.5NPT	1.5" NPT Displacement Hull Tank Adapter
TFT-5H	SAE 5-Bolt Pattern Non-Displacement Hull Focus Tube
TFT-1.25BSP	1.25" BSP Non-Displacement Hull Focus Tube
TFT-1.5NPT	1.5" NPT Non-Displacement Hull Focus Tube
TFTDBE-5H SAE	5-Bolt Pattern Focus Tube with Dead Band Eliminator

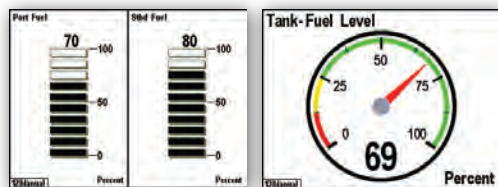
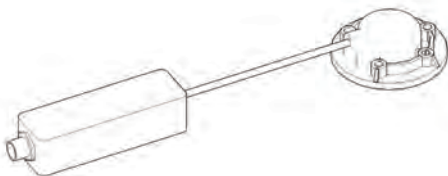
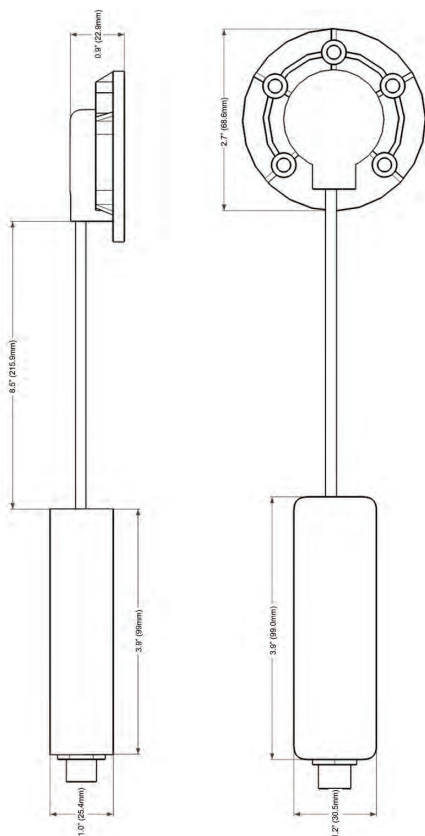

DSM150 & DSM250 Screen Shots

Specifications

Parameter	Value	Comment
Accuracy	+/-2%	
Resolution	+/-1%	
Number of Tank Types	1	Fuel (Gasoline only)
Number of Tanks per Tank Type	16	16 Tanks per Tank Type Numbered 0-15
Maximum Tank Depth	24" (.61m)	
Minimum Depth Reading	2" (5.08cm)	Sensor Deadband
Support for Irregularly Shaped Tanks	Yes	Can be Calibrated for any Shape Tank
Programmable Tank Capacity	Yes	Allows Displays to Calculate Amount Remaining
Maximum Tank Angle	6°	Without focus tube
	15°	With focus tube

Certifications

Standard	Comment
NMEA 2000	Level B
Maritime Navigation and Radio Communication Equipment & Systems	Tested to IEC 60945
FCC and CE mark	Electromagnetic Compatibility

NMEA 2000® Parameter Group Numbers (PGNs)

Description	PGN #	PGN Name	Default Rate
Periodic Data PGNs	127505	Fluid Level	0.4 times/second
Response to Requested PGNs	126464	PGN List (Transmit and Receive)	N/A
	126996	Product Information	N/A
	126998	Configuration Information	N/A
Protocol PGNs	059392	ISO Acknowledge	N/A
	059904	ISO Request	N/A
	060928	ISO Address Claim	N/A
	065240	ISO Address Command	N/A
	126208	NMEA	N/A

Electrical

Parameter	Value	Comment
Operating Voltage	9 to 16 Volts	DC Voltage
Power Consumption	<100mA	Average Current Drain
Load Equivalence Number (LEN)	2	NMEA 2000® Spec. (1LEN = 50mA)
Reverse Battery Protection	Yes	Indefinitely
Load Dump Protection	Yes	Energy Rated per SAE J1113

Mechanical

Parameter	Value	Comment
Size	3.9" x 1.2" x 1.0" (99mm x 30.5mm x 25.4mm)	Interface Component
	2.7" dia. X 0.9" (68.6mm dia. x 22.9mm)	Sensor Component
	8.5" (215.9mm)	Interconnecting Cable
Weight	12 oz. (340g)	
Mounting	SAE J1810 5-hole bolt pattern	Can mount to 1.25" BSP or 1.5" NPT using available adapters

Environmental

Parameter	Value
IEC 60945 Classification	Exposed
Degree of Protection	IP67
Operating Temperature	-25°C to 55°C
Storage Temperature	-40°C to 70°C
Relative Humidity	93%RH @40° per IEC60945-8.2
Vibration	2-13.2Hz @ ±1mm, 13.2-100Hz @ 7m/s² per IEC 60945-8.7
Rain and Spray	12.5mm Nozzle @ 100liters/min from 3m for 30min per IEC 60945-8.8
Solar Radiation	Ultraviolet B, A, Visible, and Infrared per IEC 60945-8.10
Corrosion (Salt Mist)	4 times 7days @ 40°C, 95%RH after 2 hour Salt Spray Per IEC 60945-8.12
Electromagnetic Emission	Conducted and Radiated Emission per IEC 60945-9
Electromagnetic Immunity	Conducted, Radiated, Supply, and ESD per IEC 60945-10
Safety Precautions	Dangerous Voltage, Electromagnetic Radio Frequency per IEC 60945-12



TLM200 Tank Level Monitor (104" Depth)

Maretron's TLM200 is used to sense fluid levels of tanks using ultrasonic technology. Ultrasonic, or sound waves, are transmitted via the TLM200 mounted at the top of the tank and the flight times of the sound waves to and from the fluid are measured much like a depth sensor. What this means for you is that there are no difficult to handle long probes protruding into the tank, which often foul and/or corrode. Once the TLM200 calculates and broadcast the fluid level over the NMEA 2000® network, you can observe tank levels anywhere on the vessel where there is an NMEA 2000® compatible display such as the Maretron DSM150 or DSM250.

The TLM200 is capable of sensing fluid levels in tanks up to 104" (2.64m) in depth. It can be used for diesel, fresh water, waste water, black water, and oil tanks (see the TLM100 for a lower cost solution for tanks up to 40" and the TLM150 for gasoline tanks). Unlike most tank senders that only work with rectangular tanks, the TLM200 can be calibrated for irregular tank shapes so you can know the true fluid level in your tanks.



The TLM200 is mounted directly to the top of tanks using the industry standard SAE J1810 5-hole mounting pattern. The TLM200 can also be mounted to tanks with threaded tank openings using the optional 1.5" NPT adapter.

Most importantly, the TLM200 is NMEA 2000® certified so you can view any and all tank levels anywhere on the vessel when using a compatible NMEA 2000® display. The TLM200 is another key component of Maretron's N2KView® vessel monitoring and control system.

Products

PART NUMBER	DESCRIPTION
TLM200-01	Tank Level Monitor (104" Depth Tanks)
TA-5H-1.5NPT	1.5" NPT Displacement Hull Tank Adapter

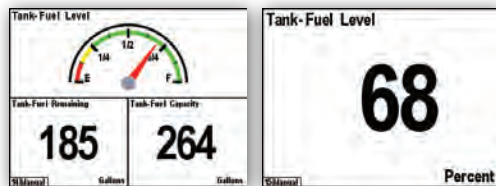
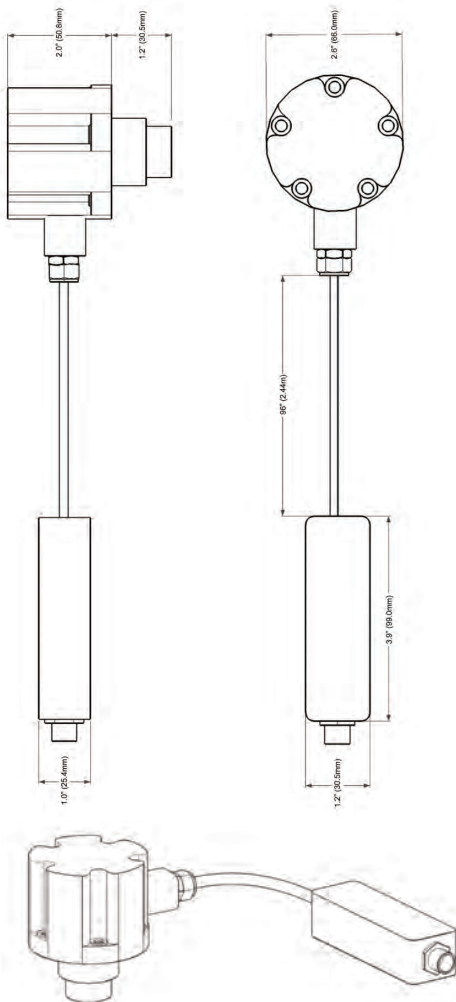

DSM150 & DSM250 Screen Shots

NMEA 2000® Parameter Group Numbers (PGNs)

Parameter	Value	Comment
Accuracy	+/-2%	
Resolution	+/-1%	
Number of Tank Types	16	Fuel, Fresh Water, Waste water, Live well, Oil, etc.
Number of Tanks per Tank Type	16	16 Tanks per Tank Type Numbered 0-15
Maximum Tank Depth	104" (2.64m)	
Minimum Depth Reading	6" (15.24cm)	Sensor Deadband
Support for Irregularly Shaped Tanks	Yes	Can be Calibrated for any Shape Tank
Programmable Tank Capacity	Yes	Allows Displays to Calculate Amount Remaining
Maximum Tank Angle	6°	

Standard	Comment
NMEA 2000	Level B
Maritime Navigation and Radio Communication Equipment & Systems	Tested to IEC 60945
FCC and CE mark	Electromagnetic Compatibility

Description	PGN #	PGN Name	Default Rate
Periodic Data PGNs	127505	Fluid Level	0.4 times/second
Response to Requested PGNs	126464	PGN List (Transmit and Receive)	N/A
	126996	Product Information	N/A
	126998	Configuration Information	N/A
Protocol PGNs	059392	ISO Acknowledge	N/A
	059904	ISO Request	N/A
	060928	ISO Address Claim	N/A
	065240	ISO Address Command	N/A
	126208	NMEA	N/A

Parameter	Value	Comment
Operating Voltage	9 to 16 Volts	DC Voltage
Power Consumption	<100mA	Average Current Drain
Load Equivalence Number (LEN)	2	NMEA 2000® Spec. (1LEN = 50mA)
Reverse Battery Protection	Yes	Indefinitely
Load Dump Protection	Yes	Energy Rated per SAE J1113

Parameter	Value	Comment
Size	3.9" x 1.2" x 1.0" (99mm x 30.5mm x 25.4mm)	Interface Component
	2.6" dia. X 2.0" (66.0mm dia. x 50.8mm)	Sensor Component
	96" (2.44mm)	Interconnecting Cable
Weight	15 oz. (425g)	
Mounting	SAE J1810 5-hole bolt pattern	Can mount to 1.5" NPT using optional accessory

Parameter	Value
IEC 60945 Classification	Exposed
Degree of Protection	IP67
Operating Temperature	-25°C to 55°C
Storage Temperature	-40°C to 70°C
Relative Humidity	93%RH @40° per IEC60945-8.2
Vibration	2-13.2Hz @ ±1mm, 13.2-100Hz @ 7m/s ² per IEC 60945-8.7
Rain and Spray	12.5mm Nozzle @ 100liters/min from 3m for 30min per IEC 60945-8.8
Solar Radiation	Ultraviolet B, A, Visible, and Infrared per IEC 60945-8.10
Corrosion (Salt Mist)	4 times 7days @ 40°C, 95%RH after 2 hour Salt Spray Per IEC 60945-8.12
Electromagnetic Emission	Conducted and Radiated Emission per IEC 60945-9
Electromagnetic Immunity	Conducted, Radiated, Supply, and ESD per IEC 60945-10
Safety Precautions	Dangerous Voltage, Electromagnetic Radio Frequency per IEC 60945-12



TLA100 Tank Level Adapter

The TLA100 is used to adapt commercially available resistive tank senders to the NMEA 2000® network. This allows you to observe tank levels anywhere on the vessel where there are NMEA 2000® compatible displays such as the Maretron DSM150 or DSM250.

The TLA100 is compatible with both the American standard (240-30 ohm) and the European standard (10-180 ohm) resistive senders. In fact, the TLA100 can be calibrated for any resistance between 0 and 300 ohms.

Unlike most tank senders that only work with rectangular tanks, the TLA100 can be calibrated for irregular tank shapes so you know the true level of the tanks. You can also use the TLA100 with analog gauges at the same time as NMEA 2000® so you don't have to give up existing analog gauges to enjoy the advantages of digitally networked information.

Products

PART NUMBER	DESCRIPTION
TLA100-01	Tank Level Adapter



The Maretron TLA100 has the following features:

- NMEA 2000® Interface
- Adapts American standard (240-30 ohm) resistive senders to NMEA 2000® Network
- Adapts European standard (10-180 ohm) resistive senders to NMEA 2000® Network
- Can be user calibrated for any Resistance Range from 0 to 300 Ohms or 300 to 0 Ohms
- Accommodates Irregularly Shaped Tanks with 16 Point Calibration
- 16 Programmable Tank Types Including Fuel, Fresh Water, Waste Water, Live Well
- Programmable Tank Number(s) Up to 16 per Tank Type
- Programmable Tank Capacity
- Works Alongside of Analog Gauges
- Can be Used Standalone without Analog Gauges





Side View



End View

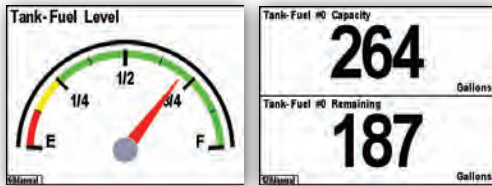
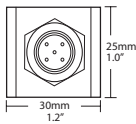

DSM150 & DSM250 Screen Shots

Specifications

Parameter	Value	Comment
Accuracy	+/-2%	Does Not Include Inaccuracies of Analog Gauge or Sender
Resolution	+/-1%	Worst Case (Resolution Better at High Resistance Values)
Number of Tank Types	16	Fuel, Fresh Water, Waste Water, Live Well, Oil, etc.
Number of Tanks per Tank Type	16	16 Tanks per Tank Type Numbered 0-15
American Standard Senders	240-30 ohms	Standard Sender Types are User Selectable
European Standard Senders	10-180 ohms	Standard Sender Types are User Selectable
Calibration Resistance Range	0-300 ohms	Non-Standard Sender Calibration
Support for Irregularly Shaped Tanks	Yes	Can be Calibrated for any Shape Tank
Programmable Tank Capacity	Yes	Allows Displays to Calculate Amount Remaining
Analog Gauge Support	Yes	Can be Used With or Without Analog Gauges

Certifications

Standard	Comment
NMEA 2000® Standard	Level B+
Maritime Navigation and Radio Communication Equipment & Systems	IEC 61162-3
Maritime Navigation and Radio Communication Equipment & Systems	IEC 60945
FCC and CE mark	Electromagnetic Compatibility

NMEA 2000® Parameter Group Numbers (PGNs)

Description	PGN #	PGN Name	Default Rate
Periodic Data PGNs	127505	Fluid Level	0.4 Times/Second
Response to Requested PGNs	126464	PGN List (Transmit and Receive)	N/A
	126996	Product Information	N/A
	126998	Configuration Information	N/A
Protocol PGNs	059392	ISO Acknowledge	N/A
	059904	ISO Request	N/A
	060928	ISO Address Claim	N/A
	065240	ISO Address Command	N/A
	126208	NMEA Request/Command/Acknowledge	N/A

Electrical

Parameter	Value	Comment
Operating Voltage	9 to 16 Volts	DC Voltage
Power Consumption	<100mA	Average Current Drain
Load Equivalence Number (LEN)	2	NMEA 2000® Spec. (1LEN = 50mA)
Reverse Battery Protection	Yes	Indefinitely
Load Dump Protection	Yes	Energy Rated per SAE J1113

Mechanical

Parameter	Value	Comment
Size	3.9" x 1.2" x 1.0" (99mm x 30mm x 25mm)	Excluding NMEA 2000® Connector & Cable
Weight	9 oz. (255g)	
Mounting	Any Orientation	

Environmental

Parameter	Value
IEC 60945 Classification	Exposed
Degree of Protection	IP67
Operating Temperature	-25°C to 55°C
Storage Temperature	-40°C to 70°C
Relative Humidity	93%RH @40° per IEC60945-8.2
Vibration	2-13.2Hz @ ±1mm, 13.2-100Hz @ 7m/s² per IEC 60945-8.7
Rain and Spray	12.5mm Nozzle @ 100liters/min from 3m for 30min per IEC 60945-8.8
Solar Radiation	Ultraviolet B, A, Visible, and Infrared per IEC 60945-8.10
Corrosion (Salt Mist)	4 times 7days @ 40°C, 95%RH after 2 hour Salt Spray Per IEC 60945-8.12
Electromagnetic Emission	Conducted and Radiated Emission per IEC 60945-9
Electromagnetic Immunity	Conducted, Radiated, Supply, and ESD per IEC 60945-10
Safety Precautions	Dangerous Voltage, Electromagnetic Radio Frequency per IEC 60945-12



Engine Monitoring

J2K100 - *J1939 to NMEA 2000® Gateway*

FFM100 - *Fuel Flow Monitor*

Engines are one of the more important systems on a vessel and the ability to monitor them is essential for assuring safe and trouble free passages. Maretron's engine monitoring products provide critical information like oil pressure and coolant temperature, which gives you an early warning of potential problems before things get out of control. And when coupled with Maretron's user interface products, you don't have to constantly stare at the gauges to detect potential problems because programmable alerts or alarms can be set for any parameter. In addition, Maretron offers state-of-the-art fuel flow monitoring that lets you find the vessel's optimum running points for substantial fuel savings.



J2K100

J1939 to NMEA 2000® Gateway



FFM100

Fuel Flow Monitor



J2K100 *J1939 to NMEA 2000® Gateway*

Maretron's J2K100 attaches directly into J1939 networks of compatible engines, transmissions, and gensets and converts the J1939 data to the new marine digital interface (NMEA 2000®). Critical engine, transmission, and genset data is then distributed throughout the vessel over a single cable where it can be monitored by any NMEA 2000® compatible display.

The J2K100 can also be used as part of a complete fuel computer. Simply connect the J2K100 together with Maretron universal displays (DSM150, DSM250, N2KView®) and GPS antenna/receiver (GPS200) and you have a system capable of displaying gallons per hour and/or miles per gallon.



Products

PART NUMBER	DESCRIPTION
J2K100-01	J1939 to NMEA 2000® Gateway
MCF-2M-D4	J2K100 adapter Micro female to Deutsch 4 Pin 2 Meter Cordset
MCF-2M-D12	J2K100 adapter Micro female to Deutsch 12 Pin 2 Meter Cordset
MCF-2M-D12CAT	J2K100 adapter Micro female to Deutsch 12 Pin 2 T cable



The J2K100 converts the following information:

- AC Generator Current
- AC Generator Frequency
- AC Generator Voltage
- Tachometer
- Engine Hours
- Coolant Pressure
- Coolant Water Temperature
- Engine Oil Pressure
- Engine Oil Temperature
- Boost Pressure
- Fuel Rate Monitoring
- Charging Voltage
- Percent Engine Load
- Percent Engine Torque
- Rated Engine Speed
- VIN
- Software ID
- Transmission Gear
- Transmission Oil Pressure
- Transmission Oil Temperature

The J2K100 is compatible with any engine, transmission, or genset equipped with a J1939 interface, including products from the following manufacturers:

- Caterpillar
- Cummins
- Detroit Diesel
- John Deere
- Kohler
- Northern Lights
- Onan
- Perkins
- Steyr
- Volvo Penta
- Yanmar

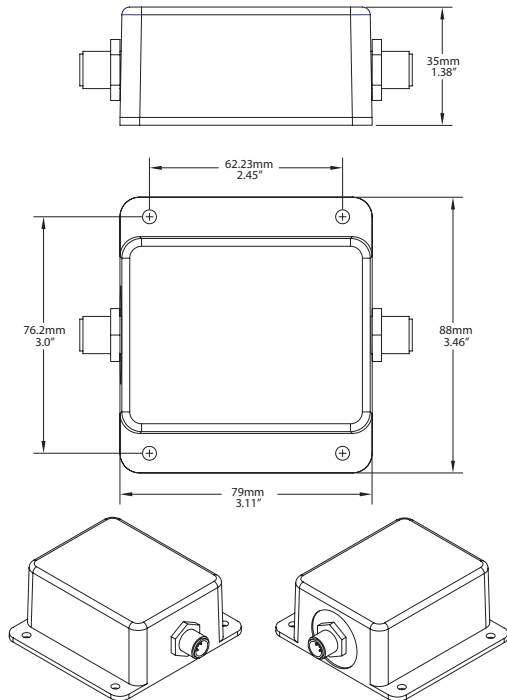

N2KView Engine Screen

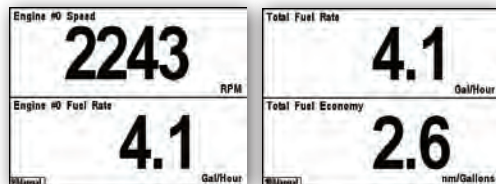

DSM150 & DSM250 Screen Shots

Specifications (J1939 Data Translated to NMEA 2000® Data)

J1939 SPN/PGN	Description	NMEA 2000® PGN
190 / 61444	Engine Speed	127488
102 / 65270	Engine Turbocharger Boost Pressure	127488
100 / 65263	Engine Oil Pressure	127489
175 / 65262	Engine Oil Temperature 1	127489
110 / 65262	Engine Coolant Temperature	127489
167 / 65271	Alternator Potential (Voltage)	127489
183 / 65266	Engine Fuel Rate	127489
247 / 65253	Engine Total Hours of Operation	127489
109 / 65263	Engine Coolant Pressure	127489
94 / 65263	Engine Fuel Delivery Pressure	127489
92 / 61443	Engine Percent Load at Current Speed	127489
513 / 61444	Actual Engine – Percent Torque	127489
189 / 65214	Engine Rated Speed	127498
237 / 65260	Vehicle Identification Number	127498
234 / 65242	Software Identification	127498
523 / 61445	Transmission Current Gear	127493
127 / 65272	Transmission Oil Pressure	127493
177 / 65272	Transmission Oil Temperature	127493

Certifications

Standard	Comment
NMEA 2000® Standard	Level B+
Maritime Navigation and Radio Communication Equipment & Systems	IEC 61162-3
Maritime Navigation and Radio Communication Equipment & Systems	IEC 60945
FCC and CE mark	Electromagnetic Compatibility

NMEA 2000® Parameter Group Numbers (PGNs)

Description	PGN #	PGN Name	Default Rate
Periodic Data PGNs	127488	Engine Parameters, Rapid Update	10 times/second
	127489	Engine Parameters, Dynamic	1 time/second
	127498	Engine Parameters, Static	N/A
	127493	Transmission Parameters, Dynamic	10 times/second
	65030	J1939 Generator Average Basic AC Quantities	10 times/second
	65226	J1939 Diagnostic Message #1	N/A
	65227	J1939 Diagnostic Message #2	N/A
	65228	J1939 Diagnostic Message #3	N/A
	65229	J1939 Diagnostic Message #4	N/A
	65230	J1939 Diagnostic Message #5	N/A
	65231	J1939 Diagnostic Message #6	N/A
	65232	J1939 Diagnostic Message #8	N/A
Response to Request PGNs	65234	J1939 Diagnostic Message #10	N/A
	65235	J1939 Diagnostic Message #11	N/A
	65236	J1939 Diagnostic Message #12	N/A
	126464	PGN List (Transmit and Receive)	N/A
Protocol PGNs	126996	Product Information	N/A
	126998	Configuration Information	N/A
	059392	ISO Acknowledge	N/A
Maretron Proprietary PGNs	059904	ISO Request	N/A
	060928	ISO Address Claim	N/A
	065240	ISO Address Command	N/A
	126208	NMEA Request/Command/Acknowledge	N/A
126720	Configuration	N/A	

Environmental Mechanical Electrical

Parameter	Value	Comment
Operating Voltage	9 to 16 Volts	DC Voltage
Power Consumption	<150mA	Average Current Drain
Load Equivalence Number (LEN)	3	NMEA 2000® Spec. (1LEN = 50 mA)
Reverse Battery Protection	Yes	Indefinitely
Load Dump Protection	Yes	Energy Rated per SAE J1113

Parameter	Value	Comment
Size	3.11" x 3.46" x 1.38" (79mm x 88mm x 35mm)	Including Flanges For Mounting
Weight	8 oz. (227 g)	

Parameter	Value
IEC 60945 Classification	Exposed
Degree of Protection	IP67
Operating Temperature	-25°C to 55°C
Storage Temperature	-40°C to 70°C
Relative Humidity	93%RH @40° per IEC60945-8.2
Vibration	2-13.2Hz @ ±1mm, 13.2-100Hz @ 7m/s² per IEC 60945-8.7
Rain and Spray	12.5mm Nozzle @ 100liters/min from 3m for 30min per IEC 60945-8.8
Solar Radiation	Ultraviolet B, A, Visible, and Infrared per IEC 60945-8.10
Corrosion (Salt Mist)	4 times 7days @ 40°C, 95%RH after 2 hour Salt Spray per IEC 60945-8.12
Electromagnetic Emission	Conducted and Radiated Emission per IEC 60945-9
Electromagnetic Immunity	Conducted, Radiated, Supply, and ESD per IEC 60945-10
Safety Precautions	Dangerous Voltage, Electromagnetic Radio Frequency per IEC 60945-12



FFM100 Fuel/Fluid Flow Monitoring

Maretron's FFM100 provides precision fuel flow information to help optimize fuel consumption, which can save thousands of dollars in fuel operating cost. The FFM100 uses state-of-the-art, positive displacement metering technology for unprecedented accuracy. In fact, the accuracy of the FFM100 is nearly that of commercial vessel systems costing tens of thousands of dollars, yet the FFM100 costs less than existing recreational systems found on the market today. Additional benefits of the positive displacement metering technology are the elimination of flow conditioning components such as straighteners and pulsation dampers. Other flow meter technologies require flow conditioning components that increase system and installation cost. The FFM100 also uses true temperature compensation with embedded temperature sensors within the meters. The returning fuel is generally hotter than the supply fuel and if not properly compensated, inaccuracies as much as 5% can occur in computing the engine's fuel consumption. The FFM100 also detects momentary reverse flow in the fuel lines due to fluctuating pressure caused by the injection pump. Less accurate systems count the reverse fuel flow as part of the consumed fuel where the FFM100 properly accounts for momentary reverse flow. Lastly, the FFM100 can be used for fluid types other than fuel (e.g., water, oil, etc.) by ordering the appropriate flow sender.

Products

PART NUMBER	DESCRIPTION
FFM100-01	Fuel Flow Monitor
M1AR	Fuel Flow Sensor 2-100 LPH (0.53-26.4 GPH)
M2AR	Fuel Flow Sensor 25-500 LPH (6.6-132 GPH)
M4AR	Fuel Flow Sensor 180-1500 LPH (48-396 GPH)
M8AR	Fuel Flow Sensor 8-70 LPM (2.1-18.5 GPM)
M16AR	Fuel Flow Sensor 10-100 LPM (2.6-26.4 GPM)



The following accessories are available for the FFM100:



M1AR

M2AR

M4AR

M8AR

M16AR

- FFM100 converts a variety of flow senders (e.g., fuel, water, etc.) to NMEA 2000® Network Data
- All flow senders ordered separately depending on application (i.e., single fuel flow sender for gas engine, dual fuel flow senders for diesel engine, water flow sender for sea water, etc.)
- Fuel flow senders to facilitate fuel consumption optimization for reduced fuel operating cost
- Fuel flow senders use positive displacement metering technology for superior accuracy over other measurement technology such as turbine meters
- Fuel flow senders do not require costly fuel conditioning components like flow straighteners and pulse dampers
- Fuel flow senders implement true temperature compensation with precision built-in thermistors for increased accuracy
- Fuel flow senders automatically detect reverse flow due to fluctuating pressure difference from injection pumps
- Fuel flow senders pass particle sizes up to 70 micrometers (diesel fuel filters normally filter down to 2 micrometers to prevent clogging injectors)

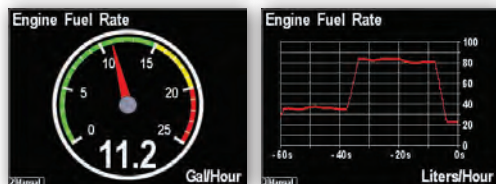
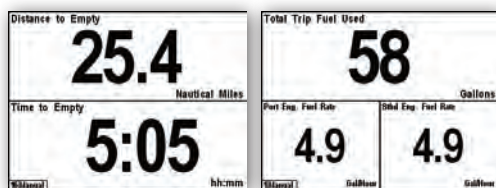
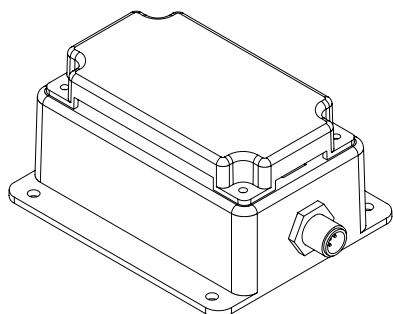
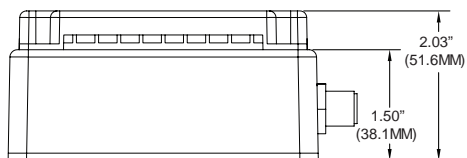
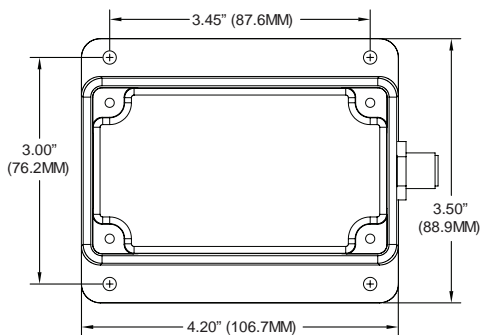

DSM150 & DSM250 Screen Shots

Specifications

Parameter	Value	Comment
Accuracy (Differential Mode)	±1.75% of reading	Using M1RSP-2R-E8 sensors K factors programmed into FFM100 4:1 fuel feed/fuel consumption ratio
Accuracy (Two Independent Sensors)	±0.25% of reading	Using M1RSP-2R-E8 sensors K factors programmed into FFM100
Resolution	0.1 LPH (0.026 GPH)	

Certifications

Parameter	Comment
NMEA 2000®	Level A
Maritime Navigation and Radiocommunication Equipment & Systems	IEC 61162-3
Maritime Navigation and Radiocommunication Equipment & Systems	Tested to IEC 60945
FCC and CE Mark	Electromagnetic Compatibility

NMEA 2000® Parameter Group Numbers (PGNs)

Description	PGN #	PGN Name	Default Rate
Periodic Data PGNs	065286	Fluid Flow Rate (Maretron Proprietary)	2 Times/Second
	065287	Trip Volume (Maretron Proprietary)	2 Times/Second
	127489	Engine Parameters, Dynamic	2 Times/Second
	127497	Trip Parameters, Engine	1 Time/Second
	130312	Temperature	0.5 Times/Second
	130316	Temperature, Extended Range	0.5 Times/Second
Response to Requested PGNs	126464	PGN List (Transmit and Receive)	N/A
	126996	Product Information	N/A
	126998	Configuration Information	N/A
Protocol PGNs	059392	ISO Acknowledge	N/A
	059904	ISO Request	N/A
	060928	ISO Address Claim	N/A
	065240	ISO Address Command	N/A
	126208	NMEA	N/A
Maretron Proprietary PGNs	128720	Configuration	N/A

Electrical

Parameter	Value	Comment
Operating Voltage	9 to 32 Volts	DC Voltage
Power Consumption	150mA	Maximum Current Drain
Load Equivalence Number (LEN)	3	NMEA 2000® Spec. (1LEN = 50mA)
Reverse Battery Protection	Yes	Indefinitely
Load Dump Protection	Yes	Energy Rated per SAE J1113

Mechanical

Parameter	Value	Comment
Size	3.50" x 4.20" x 2.03" (88.9mm x 106.7mm x 51.6mm)	Including Flanges for Mounting
Weight	13 oz. (368.5 g)	

Environmental

Parameter	Value
IEC 60945 Classification	Exposed
Degree of Protection	IP64
Operating Temperature	-25°C to 55°C
Storage Temperature	-40°C to 70°C
Relative Humidity	93%RH @40° per IEC60945-8.2
Vibration	2-13.2Hz @ ±1mm, 13.2-100Hz @ 7m/s² per IEC 60945-8.7
Solar Radiation	Ultraviolet B, A, Visible, and Infrared per IEC 60945-8.10
Corrosion (Salt Mist)	4 times 7 days @ 40°C, 95%RH after 2 hour Salt Spray Per IEC 60945-8.12
Electromagnetic Emission	Conducted and Radiated Emission per IEC 60945-9
Electromagnetic Immunity	Conducted, Radiated, Supply, and ESD per IEC 60945-10
Safety Precautions	Dangerous Voltage, Electromagnetic Radio Frequency per IEC 60945-12



Electrical Monitoring and Control

ACM100 - *Alternating Current Monitor*

DCM100 - *Direct Current Monitor*

DCR100 - *Direct Current Relays*

RIM100 - *Run Indicator Module*

Maretron offers the widest variety of NMEA 2000® electrical monitoring and control products in the industry. We have products for monitoring your AC electrical systems whether it is shore power, generators, or inverters, plus we have products for monitoring your DC systems whether it is batteries, solar panels, or wind power. In addition to electrical monitoring products, Maretron offers solid state relays for controlling DC loads (DCR100). The DCR100 not only allows you to control up to six DC loads from any NMEA 2000® compatible display, but you can monitor the current flowing to the load and be alerted if a bulb or pump is inadvertently burned out. Lastly, Maretron's Run Indicator Module (RIM100) lets you know when electrical devices are energized and operating. The RIM100 even includes counters and timers so you can keep track of how many times electrical circuits are turned on. Just imagine knowing exactly how many times the bilge pump turns on and how long it has run, which provides yet another early warning system for detecting potential problems.



ACM100

Alternating Current Monitor



DCM100

Direct Current Monitor



DCR100

Direct Current Relays



RIM100

Run Indicator Module



ACM100 *Alternating Current Monitor*

Maretron's ACM100 is a device which monitors AC power sources and outputs information about these sources onto the industry standard NMEA 2000® marine data network. ACM100 output information is then displayed with networked NMEA 2000® equipment such as the Maretron DSM150 or DSM250 dedicated display or with NMEA 2000® compatible software such as Maretron N2KView®.



Products

PART NUMBER	DESCRIPTION
ACM100-01	Alternating Current (AC) Monitor
M000630	100 Amp AC Transducer with Cable
M000612	400 Amp AC Transducer with Cable

The following accessories are available for the ACM100:



M000630



M000612



- NMEA 2000® Interface
- Waterproof Connectors
- Sealed Waterproof Enclosure
- Opto-Isolated from NMEA 2000® Eliminating Potential Ground Loops
- Monitoring of busses carrying AC power and transmitting:
 - Voltage
 - Frequency
- Monitoring AC Power Sources such as Utilities and Generators and transmitting:
 - Voltage
 - Current
 - Frequency
 - Real Power
 - Reactive Power
 - Apparent Power
 - Power Factor
 - Total Energy Imported
 - Total Energy Exported

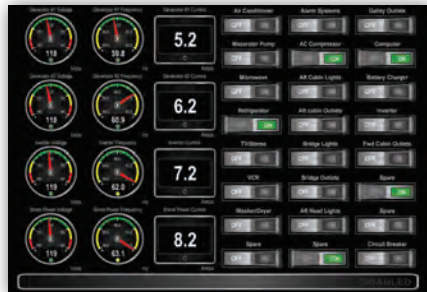
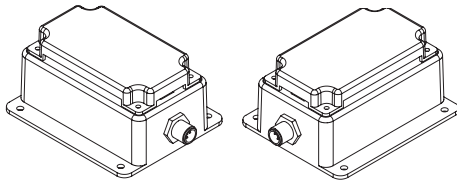
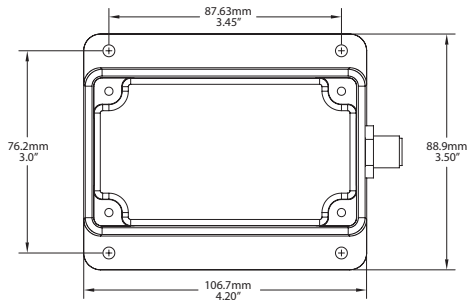
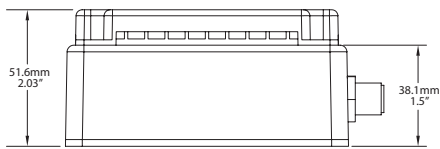

N2KView Screen

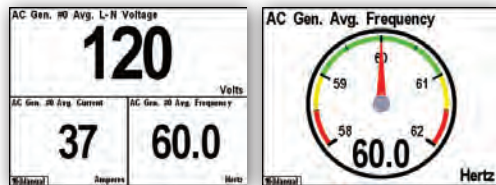

DSM150 & DSM250 Screen Shots

Specifications

Parameter	Value	Comment
Measurement Capabilities		Single Phase 120, 208, 230, 240
		Split Phase 120/240
		3-Phase Delta 208, 230, 400, 480, 600
		3-Phase Wye 208Y/120, 400Y/230, 415Y/240, 480Y/277, 600Y/347
		Delta with Wild Phase 120/208/240
Measurement Voltage Range	0-380 VAC	Line-to-Neutral
Measurement Voltage Accuracy	±1%	
Measurement Current Range	0-100 A	With included current transducer (0 to 400A with optional transducer)
Measurement Current Accuracy	±1%	With included current transducer
Measurement Frequency Range	30-80Hz	
Measurement Frequency Accuracy	0.5Hz	Typical

Certifications

Standard	Comment
NMEA 2000® Standard	Level A
Maritime Navigation and Radiocommunication Equipment & Systems	IEC 61162-3
Maritime Navigation and Radiocommunication Equipment & Systems	IEC 60945
FCC and CE Mark	Electromagnetic Compatibility

Parameter Group Numbers (PGNs)

Description	PGN #	PGN Name	Default Rate
Periodic Data PGNs	65001-65003	Bus Phase A-C Basic AC Quantities	Disabled
	65004	Bus Average Basic AC Quantities	2 times/second
	65005	Utility Total AC Energy	2 times/second
	65006-65014	Utility Phase A-C Power and Basic Quantities	Disabled
	65015	Utility Total AC Reactive Power	2 times/second
	65016	Utility Total AC Power	2 times/second
	65017	Utility Average Basic AC Quantities	2 times/second
	65018	Generator Total AC Energy	2 times/second
	65019-65027	Generator Phase A-C Power and Basic Quantities	Disabled
	65028	Generator Total AC Reactive Power	2 times/second
Response to Requested PGNs	65029	Generator Total AC Power	2 times/second
	65030	Generator Average Basic AC Quantities	2 times/second
	126464	PGN List (Transmit and Receive)	N/A
	126996	Product Information	N/A
Protocol PGNs	126998	Configuration Information	N/A
	059392	ISO Acknowledge	N/A
	059904	ISO Request	N/A
	060928	ISO Address Claim	N/A
	065240	ISO Address Command	N/A
Maretron Proprietary PGNs	126208	NMEA	N/A
	126720	Configuration	N/A

Electrical

Parameter	Value	Comment
Operating Voltage	9 to 32 Volts	DC Voltage
Power Consumption	100 mA	NMEA 2000® Interface
Load Equivalence Number (LEN)	2	NMEA 2000® Spec. (1LEN = 50 mA)
Reverse Battery Protection	Yes	Indefinitely
Load Dump Protection	Yes	Energy Rated per SAE J1113

Mechanical

Parameter	Value	Comment
Size	3.50" x 4.20" x 2.03" (88.9mm x 106.7mm x 51.6mm)	Including Flanges for Mounting
Weight	13 oz. (368.5 g)	

Environmental

Parameter	Value
IEC 60945 Classification	Exposed
Degree of Protection	IP64
Operating Temperature	-25°C to 55°C
Storage Temperature	-40°C to 70°C
Relative Humidity	93%RH @40° per IEC60945-8.2
Vibration	2-13.2Hz @ ±1mm, 13.2-100Hz @ 7m/s² per IEC 60945-8.7
Solar Radiation	Ultraviolet B, A, Visible, and Infrared per IEC 60945-8.10
Corrosion (Salt Mist)	4 times 7days @ 40°C, 95%RH after 2 hour Salt Spray Per IEC 60945-8.12
Electromagnetic Emission	Conducted and Radiated Emission per IEC 60945-9
Electromagnetic Immunity	Conducted, Radiated, Supply, and ESD per IEC 60945-10
Safety Precautions	Dangerous Voltage, Electromagnetic Radio Frequency per IEC 60945-12



DCM100 *Direct Current Monitor*

Maretron's DCM100 DC Monitor is an advanced electronic monitoring device used to measure the voltage and current of any direct current (DC) power source or load. Examples of DC power sources that can be monitored with the DCM100 include batteries, alternators, solar panels, and wind generators. The DCM100 can also be used to monitor DC loads like inverters, windlasses, DC refrigerators, or any DC branch circuit. When the DCM100 is used to monitor batteries, sophisticated circuitry and software algorithms monitor battery temperature, load current, charging current and terminal voltage to precisely compute battery state of charge, and time remaining. To measure current, the DCM100 uses an included state-of-the-art Hall effect current sensor which simply slips over the wire – you don't have to break connections or install connectors as you do with inline shunts used by other solutions. Best of all, the DCM100 is NMEA 2000® certified so you can view any and all DC information anywhere on the vessel using a compatible NMEA 2000® display. The DCM100 is a key component of Maretron's N2KView® vessel monitoring and control system.



The following accessory is available for the DCM100:



LEMHTAx00-S

- Battery Voltage
- Battery Current
- Ripple Voltage
- Battery Case Temperature
- State of Charge
- Time Remaining
- Charge Efficiency Factor

Products

PART NUMBER	DESCRIPTION
DCM100-01	Direct Current (DC) Monitor
FC01	DCM100 Battery Harness with Fuse
LEMHTA200-S	200 Amp Current Transducer with Cable
LEMHTA400-S	400 Amp Current Transducer with Cable
LEMHTA600-S	600 Amp Current Transducer with Cable
TR3K	DCM100 Ring/Under Bolt Temperature Probe



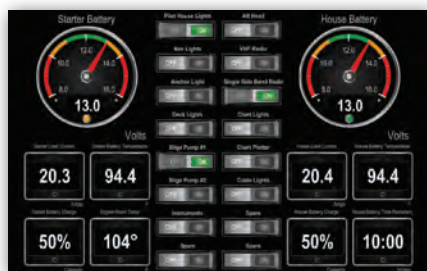
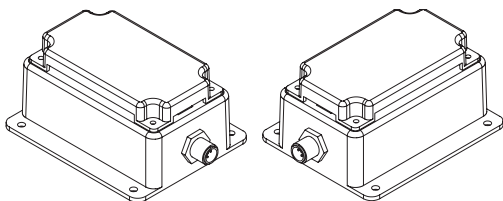
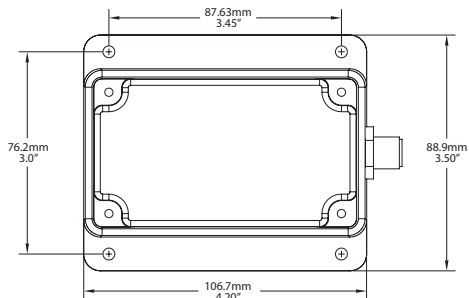
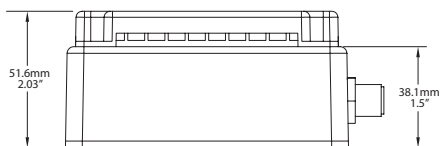

N2KView Systems Screen

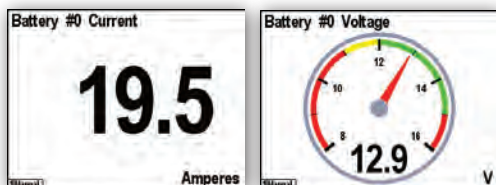

DSM150 & DSM250 Screen Shots

Certifications Specifications
NMEA 2000® Parameter Group Numbers

Parameter	Value	Comment
Battery Sense Voltage Range	0 to 50 VDC	
Battery Sense Voltage Accuracy	±100 mV	
Battery Current Range	0 to 200A	With included Hall-effect current sensor
Battery Current Accuracy	±1%	With included Hall-effect current sensor

Standard	Comment
NMEA 2000® Standard	Level A
Maritime Navigation and Radio Communication Equipment & Systems	IEC 61162-3
Maritime Navigation and Radio Communication Equipment & Systems	IEC 60945
FCC and CE mark	Electromagnetic Compatibility

Description	PGN#	PGN Name	Default Rate
Periodic Data PGNs	127506	DC Detailed Status	0.67 times/second
	127508	Battery Status	0.67 times/second
	127513	Battery Configuration Status	N/A
Response to Requested PGNs	126464	PGN List (Transmit and Receive)	N/A
	126996	Product Information	N/A
	126998	Configuration Information	N/A
Protocol PGNs	059392	ISO Acknowledge	N/A
	059904	ISO Request	N/A
	060928	ISO Address Claim	N/A
	065240	ISO Address Command	N/A
	126208	NMEA	N/A
Maretron Proprietary PGNs	128720	Configuration	N/A

Parameter	Value	Comment
Operating Voltage	9 to 16 Volts	NMEA Interface
	9 to 32 Volts	Battery Interface
Power Consumption (Battery Interface)	70mA	
Power Consumption (NMEA 2000® Connection)	50mA	
Load Equivalence Number (LEN)	1	NMEA 2000® Spec. (1 LEN = 50mA)
Reverse Battery Protection	Yes	Indefinitely
Load Dump Protection	Yes	Energy Rated Per SAE J1113

Parameter	Value	Comment
Size	3.50" x 4.20" x 2.03" (88.9mm x 106.7mm x 51.6mm)	Including Flanges for Mounting
Weight	13 oz. (368.5 g)	

Electrical

Mechanical

Environmental

Parameter	Value
IEC 60945 Classification	Exposed
Degree of Protection	IP64
Operating Temperature	-25°C to 55°C
Storage Temperature	-40°C to 70°C
Relative Humidity	93%RH @40° per IEC60945-8.2
Vibration	2-13.2Hz @ ±1mm, 13.2-100Hz @ 7m/s² per IEC 60945-8.7
Rain and Spray	12.5mm Nozzle @ 100liters/min from 3m for 30min per IEC 60945-8.8
Solar Radiation	Ultraviolet B, A, Visible, and Infrared per IEC 60945-8.10
Corrosion (Salt Mist)	4 times 7days @ 40°C, 95%RH after 2 hour Salt Spray Per IEC 60945-8.12
Electromagnetic Emission	Conducted and Radiated Emission per IEC 60945-9
Electromagnetic Immunity	Conducted, Radiated, Supply, and ESD per IEC 60945-10
Safety Precautions	Dangerous Voltage, Electromagnetic Radio Frequency per IEC 60945-12



DCR100 *Direct Current Relays*

Maretron's DCR100 contains 6 Direct Current (DC) relays, each capable of switching up to 10 amps. The DCR100 connects directly to an NMEA 2000® network, so you can turn on and off the relays from any device onboard or remotely running Maretron's N2KView® software. The DCR100 easily handles resistive DC loads like lights, or inductive DC loads like pumps and motors. The DCR100 can also be used to switch AC circuits using external relays. An added benefit of the DCR100 is that it reports the current through each of the six channels. This allows you to determine if loads are drawing too little electrical current such as burnt out bulbs, or if the loads are starting to draw too much electrical current.

Products

PART NUMBER	DESCRIPTION
DCR100-01	Direct Current Relays



- Six Relays for On / Off Control Over NMEA 2000® Network
- Each Relay Capable of Carrying Up to 10 amps
- Individual Relay Electrical Current Monitoring
- Automatic Relay Over Current Shutdown (Shuts Down at ≈ 12 amps)
- Automatic Relay Thermal Shutdown (Over Temperature Protection)
- Relays Switchable Using Maretron DSM150, DSM250, N2KView®, or N2KView® Mobile
- DCR100 Can be Configured to Activate a Buzzer, Horn, or Strobe Light as a Result of an Alert™
- Individual DCR100 Channels Can be Locked into On/Off State
- Individual DCR100 Channels Can be Configured with Default Power Up State (e.g., On/Off/Previous)

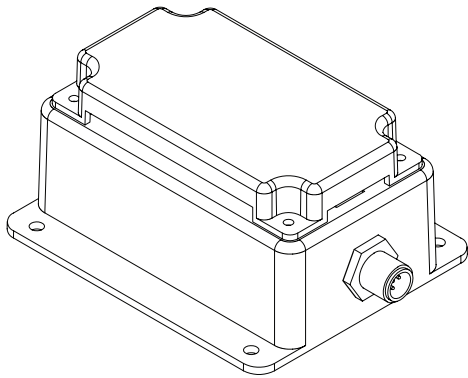
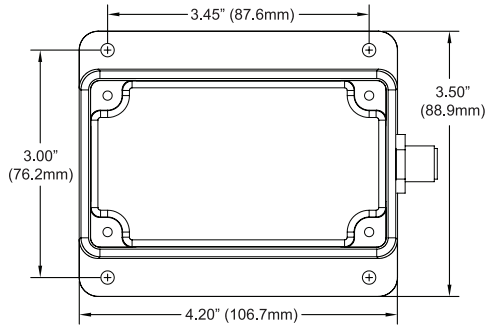
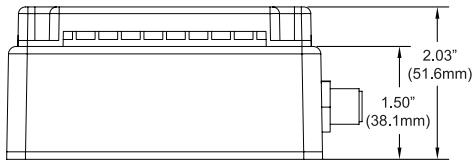

N2KView Screen Shot

Certifications

Parameter	Value	Comment
Maximum DC Switching Current	10A	Maximum Current Per Channel
DC Switching Voltage	<32 VDC	
Contact Resistance	<10 mΩ	
Current Sense Accuracy	±100 mA	

NMEA 2000® Parameter Group Numbers (PGNs)

Parameter	Comment
NMEA 2000	Level A
Maritime Navigation and Radiocommunication Equipment & Systems	IEC 61162-3
Maritime Navigation and Radiocommunication Equipment & Systems	Tested to IEC 60945
FCC and CE Mark	Electromagnetic Compatibility

Description	PGN #	PGN Name	Default Rate
Periodic Data PGNs	65284	DC Breaker Current	1 time per second
	127501	Binary Switch Bank Status	1 Time/15 seconds and on switch change
	130836	Switch Status Counter	1 Time/15 seconds and on switch change
	130837	Switch Status Timer	1 Time/15 seconds and on switch change
Response to Requested PGNs	126464	PGN List (Transmit and Receive)	N/A
	126996	Product Information	N/A
	126998	Configuration Information	N/A
Protocol PGNs	059392	ISO Acknowledge	N/A
	059904	ISO Request	N/A
	060928	ISO Address Claim	N/A
	065240	ISO Address Command	N/A
	126208	NMEA	N/A
Maretron Proprietary PGNs	126720	Configuration	N/A

Electrical

Parameter	Value	Comment
Operating Voltage	9 to 32 Volts	DC Voltage
Power Consumption	150 mA	NMEA 2000® Interface
Load Equivalence Number (LEN)	3	NMEA 2000® Spec. (1LEN = 50 mA)
Reverse Battery Protection	Yes	Indefinitely
Load Dump Protection	Yes	Energy Rated per SAE J1113

Mechanical

Parameter	Value	Comment
Size	3.50" x 4.20" x 2.03" (88.9mm x 106.7mm x 51.6mm)	Including Flanges for Mounting
Weight	13 oz. (368.5 g)	

Environmental

Parameter	Value
IEC 60945 Classification	Exposed
Degree of Protection	IP64
Operating Temperature	-25°C to 55°C
Storage Temperature	-40°C to 70°C
Relative Humidity	93%RH @40° per IEC60945-8.2
Vibration	2-13.2Hz @ ±1mm, 13.2-100Hz @ 7m/s² per IEC 60945-8.7
Solar Radiation	Ultraviolet B, A, Visible, and Infrared per IEC 60945-8.10
Corrosion (Salt Mist)	4 times 7days @ 40°C, 95%RH after 2 hour Salt Spray Per IEC 60945-8.12
Electromagnetic Emission	Conducted and Radiated Emission per IEC 60945-9
Electromagnetic Immunity	Conducted, Radiated, Supply, and ESD per IEC 60945-10
Safety Precautions	Dangerous Voltage, Electromagnetic Radio Frequency per IEC 60945-12



RIM100 *Run Indicator Module*

Maretron's Run Indicator Module monitors both AC and DC electrical circuits and reports, over an NMEA 2000® network, whether or not the electrical circuit is energized and running. The RIM100 works equally as well for monitoring manually switched loads (e.g., running lights, anchor lights, or deck lights) as it does for automatically switched loads (e.g., bilge pumps, engine exhaust/intake fans, and transfer pumps) via the RIM100 is especially useful because you know exactly when equipment is, or isn't, running.

Products

PART NUMBER	DESCRIPTION
RIM100-01	Run Indicator Module
WIF-RK30880-E	Water in Fuel Detector



- Monitors and reports the running statuses of six independently connected devices
- Works with both AC and DC loads
- Works with both automatically and manually switched loads
- Can indicate the status of a wide variety of loads
 - Bilge Pumps
 - Winches
 - Running Lights
 - Transfer Pumps
 - Exhaust/Intake Fans
 - Water in Fuel notification
- Includes built in timers and counters so you know how long and many times a load is energized

The following accessories are available for the RIM100:



WIF-RK30880-E Water in Fuel Detector

A WIF-RK30880-E Fuel detector mounted on the bottom of a fuel filter will provide a voltage when water is detected in the fuel. This voltage can be detected by the RIM100 and used to trigger an Alert or display an Indicator.

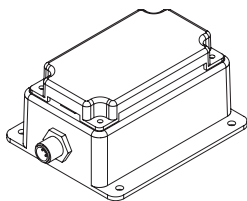
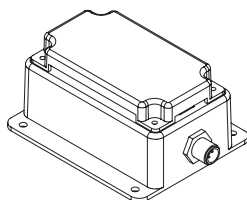
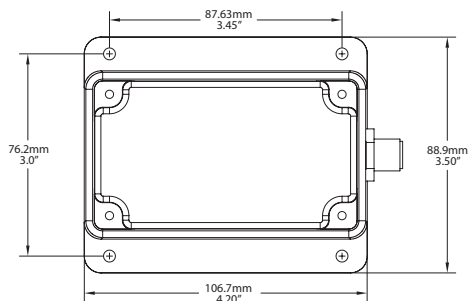
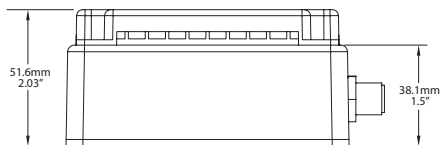

DSM150 & DSM250 Screen Shots

Certifications Specifications

Parameter	Value	Comment
Number of Channels	6	
"OFF" Voltage Range (DC)	0VDC-1VDC	
"OFF" Voltage Range (AC)	0VAC-1VAC	RMS
"ON" Voltage Range (DC)	9VDC to 240VDC	
"ON" Voltage Range (AC)	9VAC to 240VAC	RMS

Standard	Comment
NMEA 2000® Standard	Level A
Maritime Navigation and Radio Communication Equipment & Systems	IEC 61162-3
Maritime Navigation and Radio Communication Equipment & Systems	IEC 60945
FCC and CE mark	Electromagnetic Compatibility

NMEA 2000® Parameter Group Numbers

Description	PGN #	PGN Name	Default Rate
Periodic Data PGNs	127501	Binary Switch Bank Status	1 time/15 seconds and on switch change
	130836	Switch Status Counter	1 time/15 seconds and on switch change
	130837	Switch Status Timer	1 time/15 seconds and on switch change
Response to Requested PGNs	126464	PGN List (Transmit and Receive)	N/A
	126996	Product Information	N/A
	126998	Configuration Information	N/A
Protocol PGNs	059392	ISO Acknowledge	N/A
	059904	ISO Request	N/A
	060928	ISO Address Claim	N/A
	065240	ISO Address Command	N/A
	126208	NMEA Request/Command/Acknowledge	N/A
Maretron Proprietary PGNs	128720	Configuration	N/A

Electrical

Parameter	Value	Comment
Operating Voltage	9 to 32 Volts	DC Voltage
Power Consumption	100 mA	NMEA 2000® Interface
Load Equivalence Number (LEN)	2	NMEA 2000® Spec. (1LEN = 50 mA)
Reverse Battery Protection	Yes	Indefinitely
Load Dump Protection	Yes	Energy Rated per SAE J1113

Mechanical

Parameter	Value	Comment
Size	3.50" x 4.20" x 2.03" (88.9mm x 106.7mm x 51.6mm)	Including Flanges for Mounting
Weight	13 oz. (368.5 g)	

Environmental

Parameter	Value
IEC 60945 Classification	Exposed
Degree of Protection	IP64
Operating Temperature	-25°C to 55°C
Storage Temperature	-40°C to 70°C
Relative Humidity	93%RH @40° per IEC60945-8.2
Vibration	2-13.2Hz @ ±1mm, 13.2-100Hz @ 7m/s² per IEC 60945-8.7
Solar Radiation	Ultraviolet B, A, Visible, and Infrared per IEC 60945-8.10
Corrosion (Salt Mist)	4 times 7days @ 40°C, 95%RH after 2 hour Salt Spray Per IEC 60945-8.12
Electromagnetic Emission	Conducted and Radiated Emission per IEC 60945-9
Electromagnetic Immunity	Conducted, Radiated, Supply, and ESD per IEC 60945-10
Safety Precautions	Dangerous Voltage, Electromagnetic Radio Frequency per IEC 60945-12



General Systems Monitoring and Recording

SIM100 - *Switch Indicator Module*

FPM100 - *Fluid Pressure Monitor*

RAA100 - *Rudder Angle Adapter*

TMP100 - *Temperature Module*

CLM100 - *Current Loop Monitor*

VDR100 - *Vessel Data Recorder*

Maretron's general monitoring products aren't associated with a single vessel system, but rather the products are associated with monitoring a variety of systems. Take the Switch Indicator Module (SIM100) for example, which can be used for monitoring both security and safety systems. Security monitoring with the SIM100 includes magnetic door sensors, motion sensors or any other switch activated security sensor. With regards to safety systems, the SIM100 can be used for smoke, carbon monoxide, and combustible gas detection. Another good example of a general purpose monitor is the Temperature Module (TMP100). The TMP100 can be used for simple air temperature measurement like cabin temperature, or it can be used to measure your engine's exhaust gas temperature so you know whether or not you're running the engine too lean or too rich. Further general monitoring products include a data recorder that keeps track of everything that happens onboard your vessel. You can keep up to a year's worth of data on single USB thumb drive for review at anytime.



SIM100
Switch Indicator Module



FPM100
Fluid Pressure Monitor



CLM100
Current Loop Monitor



RAA100
Rudder Angle Adapter



VDR100
Vessel Data Recorder



TMP100
Temperature Module



SIM100 *Switch Indicator Module*

Maretron's Switch Indicator Module monitors switch closure devices including, but not limited to, safety equipment (e.g., heat, smoke, carbon monoxide, explosive vapor detectors), security systems (e.g., motion, vibration, glass break, door and port hole magnetic switches), and vessel monitoring equipment (e.g., valve closed/open, high water bilge). The SIM100 continually monitors these switch closure devices and broadcasts information over the NMEA 2000® network about the switch state so the crew can be alerted to potential conditions or problems that warrant further investigation. Advanced features of the SIM100 include the ability to detect whether or not power has been disconnected from the monitored device or if the signal wires have been disconnected due to either corrosion, tampering, or for any other reason (if the monitored device is so equipped). With the SIM100, you can rest assured that critical sensors are receiving power, signal wires are connected, and all the safety, security and vessel functions are under constant supervision.

- Monitors and reports the running statuses of six independently connected devices
- Can detect and report problems like opens and shorts in switch circuits



The following accessories are available for the SIM100:



Products

PART NUMBER	DESCRIPTION
SIM100-01	Switch Indicator Module
SH-002	Smoke/Heat Detector
BHW100	Bilge High Water Detector
CO-CO1224T	Carbon Monoxide (CO) Detector (Surface Mount White)
IS216	Motion Detector
VS-07.OHG	Vacuum Switch (7" Hg or 24kPa)
MS-1035	Magnetic Switch Rectangular (Indoor)
MS-1085-N	Magnetic Switch Rectangular (Outdoor)
MS-1055-N	Magnetic Switch Cylinder (Indoor/Outdoor)
MS-1075	Magnetic Switch Recessed (Indoor/Outdoor)
10233	1" FPT Cooling Water Flow Switch
10271	1-1/2" FPT Cooling Water Flow Switch
10231	2" FPT Cooling Water Flow Switch

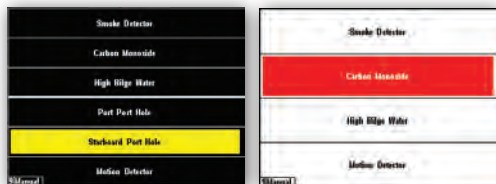
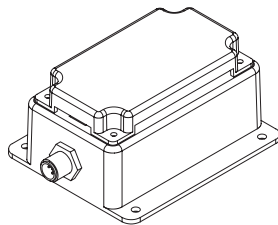
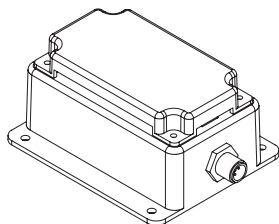
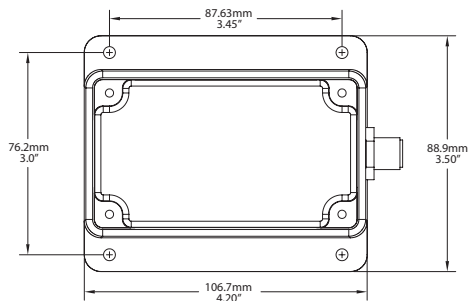
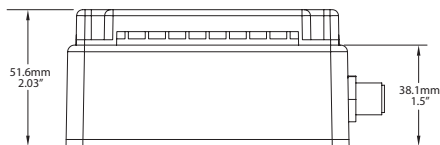

DSM150 & DSM250 Screen Shots

Specifications
Certifications

NMEA 2000® Parameter Group Numbers

Parameter	Value	Comment
End of Line Resistor	8 KΩ ± 5%	Included with Maretron-supplied sensors

Standard	Comment
NMEA 2000® Standard	Level A
Maritime Navigation and Radio Communication Equipment & Systems	IEC 61162-3
Maritime Navigation and Radio Communication Equipment & Systems	IEC 60945
FCC and CE mark	Electromagnetic Compatibility

Description	PGN #	PGN Name	Default Rate
Periodic Data PGNs	127501	Binary Switch Bank Status	1 Time/15 seconds and on switch change
	130836	Switch Status Counter	1 Time/15 seconds and on switch change
	130837	Switch Status Timer	1 Time/15 seconds and on switch change
Response to Requested PGNs	126464	PGN List (Transmit and Receive)	N/A
	126996	Product Information	N/A
	126998	Configuration Information	N/A
Protocol PGNs	059392	ISO Acknowledge	N/A
	059904	ISO Request	N/A
	060928	ISO Address Claim	N/A
	065240	ISO Address Command	N/A
	126208	NMEA Request/Command/Acknowledge	N/A
Maretron Proprietary PGNs	126720	Configuration	N/A

Electrical

Parameter	Value	Comment
Operating Voltage	9 to 32 Volts	DC Voltage
Power Consumption	100 mA	NMEA 2000® Interface
Load Equivalence Number (LEN)	2	NMEA 2000® Spec. (1LEN = 50 mA)
Reverse Battery Protection	Yes	Indefinitely
Load Dump Protection	Yes	Energy Rated per SAE J1113

Mechanical

Parameter	Value	Comment
Size	3.50" x 4.20" x 2.03" (88.9mm x 106.7mm x 51.6mm)	Including Flanges for Mounting
Weight	13 oz. (368.5 g)	

Environmental

Parameter	Value
IEC 60945 Classification	Exposed
Degree of Protection	IP64
Operating Temperature	-25°C to 55°C
Storage Temperature	-40°C to 70°C
Relative Humidity	93%RH @40° per IEC60945-8.2
Vibration	2-13.2Hz @ ±1mm, 13.2-100Hz @ 7m/s² per IEC 60945-8.7
Solar Radiation	Ultraviolet B, A, Visible, and Infrared per IEC 60945-8.10
Corrosion (Salt Mist)	4 times 7days @ 40°C, 95%RH after 2 hour Salt Spray Per IEC 60945-8.12
Electromagnetic Emission	Conducted and Radiated Emission per IEC 60945-9
Electromagnetic Immunity	Conducted, Radiated, Supply, and ESD per IEC 60945-10
Safety Precautions	Dangerous Voltage, Electromagnetic Radio Frequency per IEC 60945-12



FPM100 *Fluid Pressure Monitor*

Maretron's Fluid Pressure Monitor is used to adapt up to six pressure transducers to the NMEA 2000® network (pressure transducers sold separately). This allows you to observe fluid pressures and tank levels anywhere on the vessel where there are NMEA 2000® compatible displays. With the appropriate transducer, the FPM100 reports either pressure or vacuum for a variety of applications including water pressures, oil pressures, hydraulic pressures, or system vacuum for detecting clogged filters.

The FPM100 also has a tank level mode, so that fluid levels in a tank can be monitored via a pressure transducer mounted at the bottom of the tank and transmitted over the NMEA 2000® network. This allows you to monitor the fluid levels in tanks that are extremely deep, have internal structures, or are otherwise not suited for other tank level sensing technologies. In this mode, the FPM100 can be calibrated for irregular tank shapes so that you know the true level of the tanks.



The following accessories are available for the FPM100:



PT-0-xxxxPSI-01



PT-SNUB-01



PTS-0-x.xPSI-01



The Maretron FPM100 has the following features:

- NMEA 2000® interface
- Adapts up to six pressure transducers to the NMEA 2000® network
- Each channel independently programmable to match pressure transducer characteristics
- Each channel independently programmable in pressure/vacuum mode or tank level mode

Products

PART NUMBER	DESCRIPTION
FPM100-01	Fluid Pressure Monitor
PT-0-3PSI-01	Pressure Transducer 0 to 3 PSI
PT-0-5PSI-01	Pressure Transducer 0 to 5 PSI
PT-0-10PSI-01	Pressure Transducer 0 to 10 PSI
PT-0-50PSI-01	Pressure Transducer 0 to 50 PSI
PT-0-100PSI-01	Pressure Transducer 0 to 100 PSI
PT-0-300PSI-01	Pressure Transducer 0 to 300 PSI
PT-0-500PSI-01	Pressure Transducer 0 to 500 PSI
PT-0-1000PSI-01	Pressure Transducer 0 to 1000 PSI
PT-0-3000PSI-01	Pressure Transducer 0 to 3000 PSI
PT-0-5000PSI-01	Pressure Transducer 0 to 5000 PSI
PT-SNUB-01	Pressure Snubber
PT-V-0-1BAR-01	Pressure Transducer Vacuum to 1 Bar
PTS-0-1.5PSI-01	Submersible Pressure Transducer 0 to 1.5 PSI
PTS-0-3.0PSI-01	Submersible Pressure Transducer 0 to 3.0 PSI

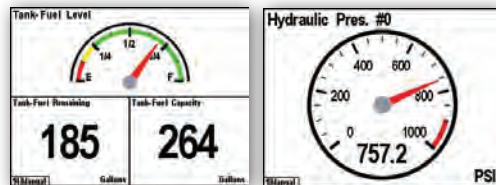
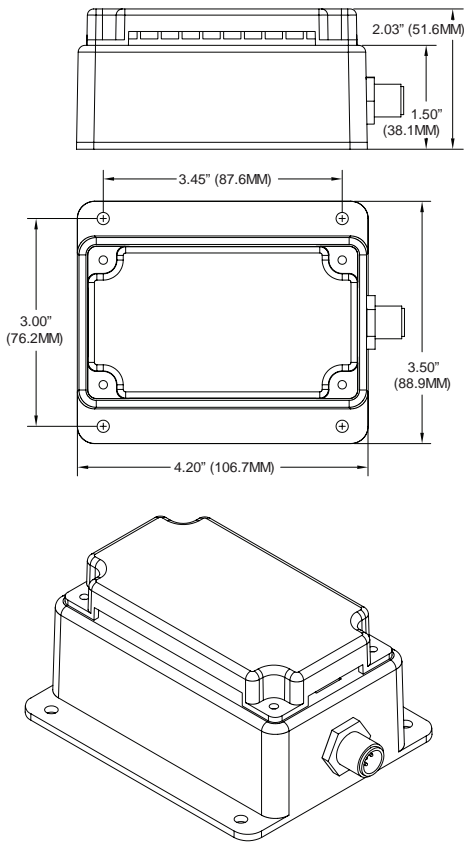

DSM150 & DSM250 Screen Shots

**Specifications
(Pressure/
Vacuum Mode)**

Parameter	Value	Comment
Accuracy	+/-1% FS	Exclusive of Pressure Transducer
Resolution	+/-0.33% FS	Over Full Pressure Transducer Range
Number of Pressure Source Types	21	Water Pressure, Atmospheric Pressure, Compressed Air Pressure, Hydraulic Pressure, Steam Pressure, 16 User Defined Sources

**Specifications
(Tank Level Mode)**

Parameter	Value	Comment
Accuracy	+/-1% FS	Exclusive of Pressure Transducer
Resolution	+/-0.33% FS	Over Full Pressure Transducer Range
Number of Tank Types	16	Fuel, Fresh Water, Waste water, Live well, Oil, etc.
Number of Tanks per Tank Type	16	16 Tanks per Tank Type Numbered 0-15
Support for Irregularly Shaped Tanks	Yes	Can be Calibrated for any Shape Tank
Programmable Tank Capacity	Yes	Allows Displays to Calculate Amount Remaining
Support for Irregularly Shaped Tanks	Yes	Can be Calibrated for any Shape Tank
Programmable Tank Capacity	Yes	Allows Displays to Calculate Amount Remaining

Certifications

Standard	Comment
NMEA 2000	Level A
Maritime Navigation and Radiocommunication Equipment & Systems	IEC 61162-3
Maritime Navigation and Radiocommunication Equipment & Systems	Tested to IEC 60945
FCC and CE Mark	Electromagnetic Compatibility

**NMEA 2000® Parameter
Group Numbers (PGNs) See
Appendix A for Details**

Description	PGN #	PGN Name	Default Rate
Periodic Data PGNs	127505	Fluid Level	0.4 Times/Second
	130314	Actual Pressure	0.5 Times/Second
Response to Requested PGNs	126464	PGN List (Transmit and Receive)	N/A
	126996	Product Information	N/A
Protocol PGNs	126998	Configuration Information	N/A
	059392	ISO Acknowledge	N/A
	059904	ISO Request	N/A
	060928	ISO Address Claim	N/A
	065240	ISO Address Command	N/A
	126208	NMEA	N/A
Maretron Proprietary PGNs	128720	Configuration	N/A

Electrical

Parameter	Value	Comment
Operating Voltage	9 to 32 Volts	DC Voltage
Power Consumption	400mA	Maximum Current Drain
Load Equivalence Number (LEN)	8	NMEA 2000® Spec. (1LEN = 50mA)
Reverse Battery Protection	Yes	Indefinitely
Load Dump Protection	Yes	Energy Rated per SAE J1113

Mechanical

Parameter	Value	Comment
Size	3.50" x 4.20" x 2.03" (88.9mm x 106.7mm x 51.6mm)	Including Flanges for Mounting
Weight	13 oz. (368.5 g)	

Environmental

Parameter	Value
IEC 60945 Classification	Exposed
Degree of Protection	IP64
Operating Temperature	-25°C to 55°C
Storage Temperature	-40°C to 70°C
Relative Humidity	93%RH @40° per IEC60945-8.2
Vibration	2-13.2Hz @ ±1mm, 13.2-100Hz @ 7m/s² per IEC 60945-8.7
Solar Radiation	Ultraviolet B, A, Visible, and Infrared per IEC 60945-8.10
Corrosion (Salt Mist)	4 times 7days @ 40°C, 95%RH after 2 hour Salt Spray Per IEC 60945-8.12
Electromagnetic Emission	Conducted and Radiated Emission per IEC 60945-9
Electromagnetic Immunity	Conducted, Radiated, Supply, and ESD per IEC 60945-10
Safety Precautions	Dangerous Voltage, Electromagnetic Radio Frequency per IEC 60945-12
Safety Precautions	Dangerous Voltage, Electromagnetic Radio Frequency per IEC 60945-12



RAA100 Rudder Angle Adapter

Maretron's RAA100 is used to adapt commercially available resistive rudder senders to the NMEA 2000® network. This allows you to observe rudder angle anywhere on the vessel where there are NMEA 2000® compatible displays such as the Maretron DSM150 or DSM250.

The RAA100 is compatible with both the American standard (240-30 ohms) and European standard (10-180 ohm) resistive senders. In fact, the RAA100 can be calibrated for any resistance between 0 and 300 ohms.

You can also use the RAA100 with analog gauges at the same time as NMEA 2000® so you don't have to give up existing analog gauges to enjoy the advantages of digitally networked information.



The Maretron RAA100 has the following features:

- NMEA 2000® Interface
- Adapts American standard (240-30 ohm) resistive senders to NMEA 2000® Network
- Adapts European standard (10-180 ohm) resistive senders to NMEA 2000® Network
- Can be Calibrated for any Resistive Sender Ranging from 0-300 Ohms or 300-0 Ohms
- Three Point Electronic Calibration eliminates need for Mechanical Adjustment or Calibration
- Can be Used Standalone Without Analog Gauges

Products

PART NUMBER	DESCRIPTION
RAA100-01	Rudder Angle Adapter

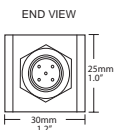
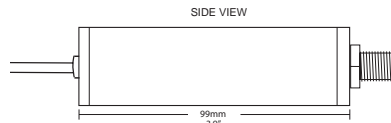
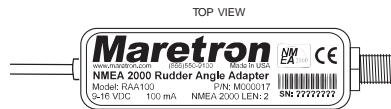

DSM150 & DSM250 Screen Shots

Specifications

Parameter	Value	Comment
Accuracy	+/-2%	Does Not Include Inaccuracies of Analog Gauge or Sender
Resolution	+/-1%	Worst Case (Resolution Better at High Resistance Values)
American Standard Senders	240-30 ohms	Standard Sender Types are User Selectable
European Standard Senders	10-180 ohms	Standard Sender Types are User Selectable
Calibration Resistance Range	0-300 ohms	Non-Standard Sender Calibration
Electronic Calibration	Yes	Eliminates need to mechanically adjust or calibrate
Analog Gauge Support	Yes	Can be Used With or Without Analog Gauges

Certifications

Standard	Comment
NMEA 2000® Standard	Level B+
Maritime Navigation and Radio Communication Equipment & Systems	IEC 61162-3
Maritime Navigation and Radio Communication Equipment & Systems	IEC 60945
FCC and CE mark	Electromagnetic Compatibility

NMEA 2000® Parameter Group Numbers (PGNs)

Description	PGN #	PGN Name	Default Rate
Periodic Data PGNs	127245	Rudder	10 Times/Second
Response to Requested PGNs	126464	PGN List (Transmit and Receive)	N/A
	126996	Product Information	N/A
	126998	Configuration Information	N/A
Protocol PGNs	059392	ISO Acknowledge	N/A
	059904	ISO Request	N/A
	060928	ISO Address Claim	N/A
	065240	ISO Address Command	N/A
	126208	NMEA Request/Command/Acknowledge	N/A
Maretron Proprietary PGNs	126720	Configuration	N/A

Electrical

Parameter	Value	Comment
Operating Voltage	9 to 16 Volts	DC Voltage
Power Consumption	<100mA	Average Current Drain
Load Equivalence Number (LEN)	2	NMEA 2000® Spec. (1LEN = 50mA)
Reverse Battery Protection	Yes	Indefinitely
Load Dump Protection	Yes	Energy Rated per SAE J1113

Mechanical

Parameter	Value	Comment
Size	3.9" x 1.2" x 1.0" (99mm x 30mm x 25mm)	Excluding NMEA 2000® Connector & Cable
Weight	9 oz. (255g)	
Mounting	Any Orientation	

Environmental

Parameter	Value
IEC 60945 Classification	Exposed
Degree of Protection	IP67
Operating Temperature	-25°C to 55°C
Storage Temperature	-40°C to 70°C
Relative Humidity	93%RH @40° per IEC60945-8.2
Vibration	2-13.2Hz @ ±1mm, 13.2-100Hz @ 7m/s² per IEC 60945-8.7
Rain and Spray	12.5mm Nozzle @ 100liters/min from 3m for 30min per IEC 60945-8.8
Solar Radiation	Ultraviolet B, A, Visible, and Infrared per IEC 60945-8.10
Corrosion (Salt Mist)	4 times 7days @ 40°C, 95%RH after 2 hour Salt Spray Per IEC 60945-8.12
Electromagnetic Emission	Conducted and Radiated Emission per IEC 60945-9
Electromagnetic Immunity	Conducted, Radiated, Supply, and ESD per IEC 60945-10
Safety Precautions	Dangerous Voltage, Electromagnetic Radio Frequency per IEC 60945-12



TMP100 *Temperature Module*

Maretron's TMP100 measures the temperature for up to 6 temperature probes and reports the information over an NMEA 2000® network. The TMP100 supports up to 4 thermistor probes and 2 high temperature thermocouple probes. Optional thermistor probes (-20°C to 80°C or -4°F to 176°F) cover a wide range of applications including cabin air temperature, engine room air temperature, refrigerator/freezer temperature, under bolt temperature (inverters, charges, pumps, motors, etc.), tank temperatures (live well bait, hot water, etc.), and air duct temperatures. The optional thermocouple probes (0°C to 900°C or 32° to 1652°F) are used to measure Exhaust Gas Temperature (EGT) as part of a comprehensive fuel management system.



The following accessories are available for the TMP100:



TR3K

TP-AAP-1

TP-IP-1

TP-EGT-1

- Six External Temperature Probes are Measured and Broadcast Over NMEA 2000 Network
- Four Channels for Thermistor Probes and 2 Channels for High Temperature Thermocouple Probes
- Wide Variety of Applications Supported with Optional Temperature Probes
 - Cabin Temperature
 - Engine Room Temperature
 - Under Bolt Temperature (Inverters, Chargers, Pumps, etc.)
 - Refrigerator/Freezer Temperature
 - Tank Temperatures (Live Well Bait, Hot Water, etc.)
 - Air Duct Temperature
 - Exhaust Gas Temperature
- Optional Temperature Probes
 - Ambient Air Temperature Probe (-20°C to 80°C or -4°F to 176°F)
 - Ring Terminal Probe (-20°C to 80°C or -4°F to 176°F)
 - Immersion Probe for Tanks or Plenums (-20°C to 80°C or -4°F to 176°F)
 - Exhaust Gas Temperature Probe (0°C to 900°C or 32° to 1652°F)



Products

PART NUMBER	DESCRIPTION
TMP100-01	Temperature Module
TR3K	TMP100 Ring/Under Bolt Temperature Probe
TP-AAP-1	TMP100 Ambient Air Temperature Probe
TP-IP-1	TMP100 Immersion (Tanks, Plenums, etc.) Temperature Probe
TP-EGT-1	TMP100 Exhaust Gas Temperature (EGT) Probe

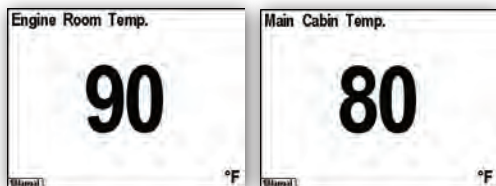
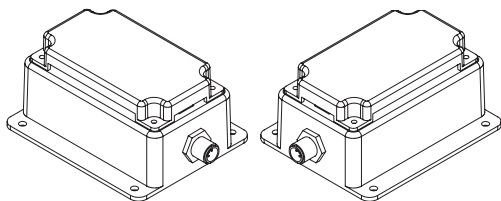
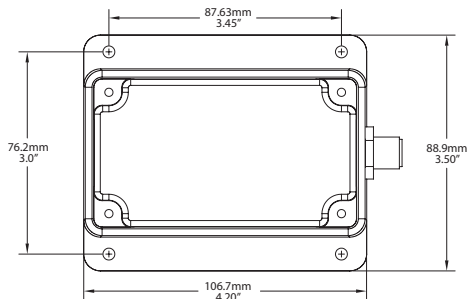
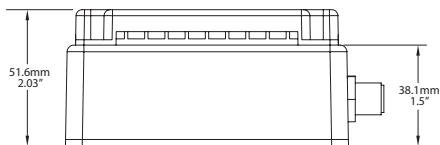

DSM150 & DSM250 Screen Shots

Certifications Specifications

Parameter	Value	Comment
Number of Thermistor Channels	4	
Number of Thermocouple Channels	2	
Measurement Range – Thermistor	-20°C to 80°C (-4°F to 176°F)	With supplied thermistor probe
Measurement Accuracy – Thermistor	± 2°C (± 3.6°F)	With supplied thermistor probe
Measurement Range – Thermocouple	0°C to 900°C (32°F to 1652°F)	With supplied thermocouple probe
Measurement Accuracy – Thermocouple	± 2°C (± 3.6°F)	With supplied thermocouple probe

NMEA 2000® Parameter Group Numbers

Standard	Comment
NMEA 2000® Standard	Level A
Maritime Navigation and Radio Communication Equipment & Systems	IEC 61162-3
Maritime Navigation and Radio Communication Equipment & Systems	IEC 60945
FCC and CE mark	Electromagnetic Compatibility

Description	PGN #	PGN Name	Default Rate
Periodic Data PGNs	130310	Environmental Parameters (not recommended for new designs; included for backward compatibility)	2 times/second
	130311	Environmental Parameters (not recommended for new designs; included for backward compatibility)	2 times/second
	130312	Temperature	0.5 times/second
	130316	Temperature, Extended Range	0.5 times/second
	130823	Temperature, High Range (Exhaust Gas Temperature) (Maretron Proprietary)	0.5 times/second
Response to Requested PGNs	126464	PGN List (Transmit and Receive)	N/A
	126996	Product Information	N/A
	126998	Configuration Information	N/A
Protocol PGNs	059392	ISO Acknowledge	N/A
	059904	ISO Request	N/A
	060928	ISO Address Claim	N/A
	065240	ISO Address Command	N/A
	126208	NMEA	N/A
Maretron Proprietary PGNs	128720	Configuration Exhaust Gas Temperature	N/A 0.5 times/second

Mechanical Electrical

Parameter	Value	Comment
Operating Voltage	9 to 32 Volts	DC Voltage
Power Consumption	100 mA	NMEA 2000® Interface
Load Equivalence Number (LEN)	2	NMEA 2000® Spec. (1LEN = 50 mA)
Reverse Battery Protection	Yes	Indefinitely
Load Dump Protection	Yes	Energy Rated per SAE J1113

Environmental

Parameter	Value	Comment
Size	3.50" x 4.20" x 2.03" (88.9mm x 106.7mm x 51.6mm)	Including Flanges for Mounting
Weight	13 oz. (368.5 g)	

Parameter	Value
IEC 60945 Classification	Exposed
Degree of Protection	IP64
Operating Temperature	-25°C to 55°C
Storage Temperature	-40°C to 70°C
Relative Humidity	93%RH @40° per IEC60945-8.2
Vibration	2-13.2Hz @ ±1mm, 13.2-100Hz @ 7m/s² per IEC 60945-8.7
Solar Radiation	Ultraviolet B, A, Visible, and Infrared per IEC 60945-8.10
Corrosion (Salt Mist)	4 times 7days @ 40°C, 95%RH after 2 hour Salt Spray Per IEC 60945-8.12
Electromagnetic Emission	Conducted and Radiated Emission per IEC 60945-9
Electromagnetic Immunity	Conducted, Radiated, Supply, and ESD per IEC 60945-10
Safety Precautions	Dangerous Voltage, Electromagnetic Radio Frequency per IEC 60945-12



CLM100 *Current Loop Monitor*

Maretron's CLM100 converts commercially available 4-20mA current loop transducers into digital data so a wide variety of information can be displayed on Maretron displays. Numerous 4-20mA current loop transducers are supported by the CLM100 including transducers for monitoring DC voltage and current, flow rate, distance, linear velocity and acceleration, angle, angular velocity and acceleration, temperature, humidity, resistance, strain gauges, force (load cell), pressure, decibels, and rotational rate. Some typical applications where the CLM100 is used together with a commercial available 4-20mA transducers include machinery monitoring using accelerometers and vibration sensors. Vibration monitoring of pumps, motors, fans, compressors, and gear boxes provides an early warning of potential problems resulting in fewer breakdowns and reduced maintenance expenses. Another application example using the CLM100 is shaft speed monitoring. A commercially available 4-20mA rotational rate transducer is coupled to the shaft of interest and the CLM100 converts the transducer data to an RPM that can be read on a compatible NMEA 2000® display. And if you're concerned about the force exerted on a mast stay or perhaps a vessel tow attachment point, commercially available clevis pins with a 4-20mA interface can be connected to the CLM100 and the corresponding load monitored using any of Maretron's display products.



The following accessories are available for the CLM100:



PT-0-xxxxPSI-01



IRHT-01



PT-SNUB-01

Products

- Used Together with Commercially Available 4-20mA Current Loop Transducers
- Converts Analog Transducer Data to Digital Data (NMEA 2000®)
- Digital Data Displayed on Maretron Displays

PART NUMBER	DESCRIPTION
CLM100-01	Current Loop Monitor
IRHT-01	Indoor Humidity/Temperature Sensor
PT-0-3PSI-01	Pressure Transducer 0 to 3 PSI
PT-0-5PSI-01	Pressure Transducer 0 to 5 PSI
PT-0-10PSI-01	Pressure Transducer 0 to 10 PSI
PT-0-50PSI-01	Pressure Transducer 0 to 50 PSI
PT-0-100PSI-01	Pressure Transducer 0 to 100 PSI
PT-0-300PSI-01	Pressure Transducer 0 to 300 PSI
PT-0-500PSI-01	Pressure Transducer 0 to 500 PSI
PT-0-1000PSI-01	Pressure Transducer 0 to 1000 PSI
PT-0-3000PSI-01	Pressure Transducer 0 to 3000 PSI
PT-0-5000PSI-01	Pressure Transducer 0 to 5000 PSI
PT-SNUB-01	Pressure Snubber
PT-V-0-1BAR-01	Pressure Transducer Vacuum to 1 Bar

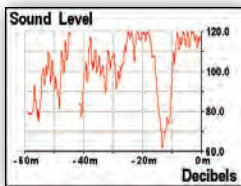
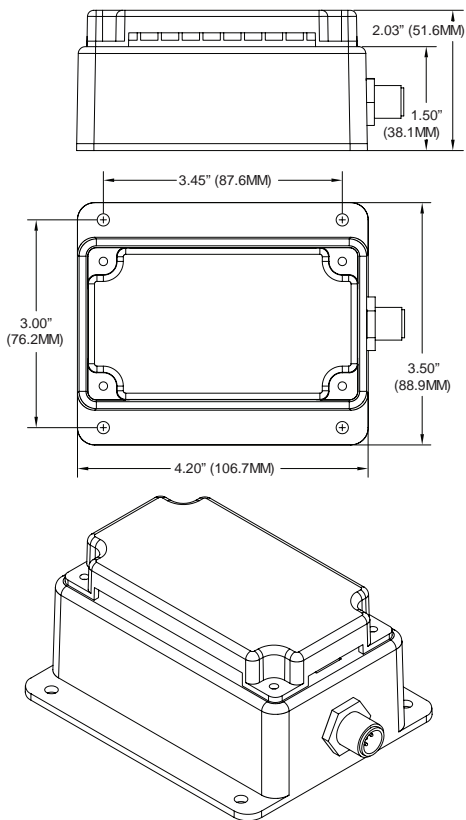

DSM150/DSM250 Screen Shots

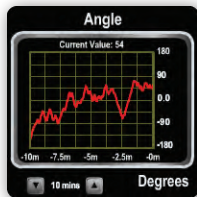

N2KView Screen Shots

Specifications

Parameter	Value	Comment
Number of Channels	6	Independently Programmable
Operating Modes	DC Voltage, DC Current, Flow Rate, Distance, Linear Velocity, Linear Acceleration, Angle, Angular Velocity, Angular Acceleration, Temperature, Humidity, Resistance, Strain Gauge, Force (Load Cell), Pressure, Decibels, Rotational Rate	
Transducer Interface	4-20mA current loop	
Current Loop Excitation Voltage	12-15 VDC	
Accuracy	+/-1% FS	Exclusive of Transducer
Resolution	+/-0.33% FS	Over Full Transducer Range

Certifications

Parameter	Comment
NMEA 2000®	Level A
Maritime Navigation and Radiocommunication Equipment & Systems	IEC 61162-3
Maritime Navigation and Radiocommunication Equipment & Systems	Tested to IEC 60945
FCC and CE Mark	Electromagnetic Compatibility

NMEA 2000® Parameter Group Numbers (PGNs)

Description	PGN #	PGN Name	Default Rate
Periodic Data PGNs	65286	Fluid Flow Rate (Maretron Proprietary)	2 Times/Second
	127751	DC Voltage/Current	0.67 Times/Second
	130313	Humidity	0.5 Times/Second
	130314	Actual Pressure	0.5 Times/Second
	130816	Temperature, Extended Range	0.5 Times/Second
	130840	Generic Sensor (Maretron Proprietary)	1 Time/Second
Response to Requested PGNs	126464	PGN List (Transmit and Receive)	N/A
	126996	Product Information	N/A
	126998	Configuration Information	N/A
Protocol PGNs	059392	ISO Acknowledge	N/A
	059904	ISO Request	N/A
	060928	ISO Address Claim	N/A
	065240	ISO Address Command	N/A
	126208	NMEA	N/A
Maretron Proprietary PGNs	128720	Configuration	N/A

Electrical

Parameter	Value	Comment
Operating Voltage	9 to 32 Volts	DC Voltage
Power Consumption	400mA	Maximum Current Drain
Load Equivalence Number (LEN)	8	NMEA 2000® Spec. (1LEN = 50mA)
Reverse Battery Protection	Yes	Indefinitely
Load Dump Protection	Yes	Energy Rated per SAE J1113

Mechanical

Parameter	Value	Comment
Size	3.50" x 4.20" x 2.03" (88.9mm x 106.7mm x 51.6mm)	Including Flanges for Mounting
Weight	13 oz. (368.5 g)	

Environmental

Parameter	Value
IEC 60945 Classification	Exposed
Degree of Protection	IP64
Operating Temperature	-25°C to 55°C
Storage Temperature	-40°C to 70°C
Relative Humidity	93%RH @40°C per IEC60945-8.2
Vibration	2-13.2Hz @ ±1mm, 13.2-100Hz @ 7m/s² per IEC 60945-8.7
Solar Radiation	Ultraviolet B, A, Visible, and Infrared per IEC 60945-8.10
Corrosion (Salt Mist)	4 times 7 days @ 40°C, 95%RH after 2 hour Salt Spray Per IEC 60945-8.12
Electromagnetic Emission	Conducted and Radiated Emission per IEC 60945-9
Electromagnetic Immunity	Conducted, Radiated, Supply, and ESD per IEC 60945-10
Safety Precautions	Dangerous Voltage, Electromagnetic Radio Frequency per IEC 60945-12



VDR100 Vessel Data Recorder

Maretron's Vessel Data Recorder (VDR100) is used to record messages transmitted from every product interconnected on the vessel's NMEA 2000® network. Each message is stored using solid-state memory technology with simple data retrieval via a removable USB flash drive. The supplied 16 Gbyte USB Flash Drive will hold weeks or more of data, and with the optional purchase of a larger USB Flash Drive, a year or more of data can be stored. And you never have to worry about losing the most recent data because the VDR100 uses a circular buffer where the oldest data is overwritten only after the entire memory is filled.

Recorded vessel data can be used in many ways including performance analysis, vessel tracking, preventative maintenance, network diagnostics, warranty incident, and accident investigation, all in an effort to reduce operating cost and improve safety. As an example of how the recorded data might be used, consider an NMEA 2000® fuel flow monitor plugged into the network, which will provide a complete record of how much fuel was used and how fast it was used. With a GPS antenna/receiver plugged into the NMEA 2000® network, you will have a complete record of where the vessel has been including its speed and course over ground.

Analyzing or graphing recorded data is done using a spreadsheet program like Microsoft® Excel®. Simply remove the USB flash drive and plug it into a PC or Mac and run Maretron's free extraction software (N2KExtractor®). Choose any or all of the recorded data including the associated dates and times and the program will create a comma delimited file (.csv) that can be read into a spreadsheet for graphing or any other type of data analysis.

With the VDR100, you have a complete record of all the information produced by NMEA 2000® products connected to the vessel's network. And because the VDR100 is engineered and manufactured to the highest standards (IEC 60945 Maritime Navigation and Radio Communication Equipment), your data is safely protected in a compact waterproof housing.

Products

PART NUMBER	DESCRIPTION
VDR100-01	Vessel Data Recorder
PX0852	USB Waterproof Cover
PX0837/5M00	Waterproof Ethernet Cable 16.4'
M003029	16GB USB Flash Drive



The following accessories are available for the VDR100:



- Data Recorded on Solid State Memory via Removable USB Flash Drive
- Circular Buffer Preserves Latest Recorded Data while Oldest Data Overwritten when Memory is Full
- Recorded Data Available for Performance Analysis, Vessel Tracking, Preventive Maintenance, and More
- Optional Waterproof USB Flash Drive Cover
- Free Data Extraction Software (N2KExtractor™) Builds Comma Delimited Files for your customized Data Analysis



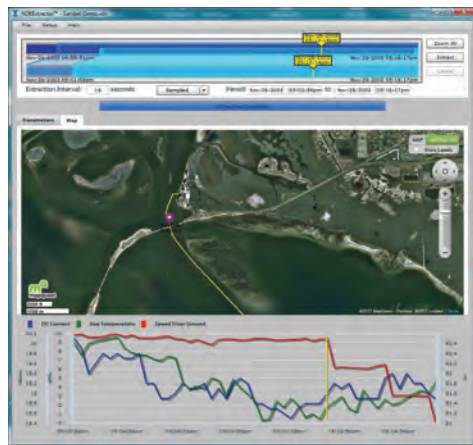
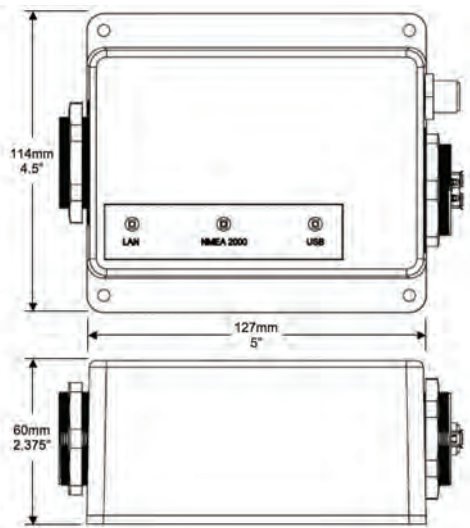

N2KExtractor® Software
Free with Purchase of VDR100

**USB Flash Drive
Sizing Guidelines**

Recording Period	Media Storage Capacity
1 second	7862 Bytes
1 minute	471,750 Bytes
1 hour	29 MBytes
1 day	680 MBytes
1 week	5 GBytes
1 month (30 days)	21 GBytes
1 year (365.25 days)	248 GBytes

Table figures are estimated assuming 25% loaded system (approximately 463 frames/sec) running continuously 24 hours/day, 7 days/week, 365 days/year.

Specifications

Parameter	Value	Comment
NMEA 2000® Connector	DeviceNet Micro-C	Industry Standard Waterproof
NMEA 2000® Isolation	Opto-Isolated	No Electrical Connection Across Bridge
USB Standard	USB 2.0	
USB Connector	USB Type A	Industry Standard Waterproof, for Connection of USB Flash Memory Device for Recording Data
USB Supported Signals	D+, D-, +5V, GND	Bi-directional Gateway
USB Auxiliary Power	+5 Volts < 200 mA	
USB Baud Rate	Up to 12 Mb/s	Full Speed USB Data Rate
Ethernet Interface	100 Mb/s	
Ethernet Connector	RJ-45	Industry Standard Waterproof

Certifications

Parameter	Comment
NMEA 2000® Standard	Level A
Maritime Navigation and Radiocommunication Equipment & Systems	IEC 61162-3
Maritime Navigation and Radiocommunication Equipment & Systems	IEC 60945
FCC and CE Mark	Electromagnetic Compatibility

**NMEA 2000® Parameter
Group Numbers (PGNs)**

Description	PGN #	PGN Name	Default Rate
Response to Requested PGNs	126464	PGN List (Transmit and Receive)	N/A
	126996	Product Information	N/A
	126998	Configuration Information	N/A
Protocol PGNs	059392	ISO Acknowledge	N/A
	059904	ISO Request	N/A
	060416	ISO Transport Protocol, Connection Management	N/A
	060160	ISO Transport Protocol, Data Transfer	N/A
	060928	ISO Address Claim	N/A
	065240	ISO Address Command	N/A
	126208	NMEA Request/Command/Acknowledge	N/A
PGNs Recorded	All	All	N/A

Electrical

Parameter	Value	Comment
Operating Voltage	9 to 32 Volts	DC Voltage
Power Consumption	<200mA	Average Current Drain
Load Equivalence Number (LEN)	4	NMEA 2000® Spec. (1LEN = 50 mA)
Reverse Battery Protection	Yes	Indefinitely
Load Dump Protection	Yes	Energy Rated per SAE J1113

Mechanical

Parameter	Value	Comment
Size	5.000" x 4.500" x 2.375" (127mm x 114mm x 60 mm)	Including Flanges for Mounting
Weight	12 oz. (340 g)	

Environmental

Parameter	Value
IEC 60945 Classification	Exposed
Degree of Protection	IP67
Operating Temperature	-25°C to 55°C
Storage Temperature	-40°C to 70°C
Relative Humidity	93%RH @40° per IEC60945-8.2
Vibration	2-13.2Hz @ ±1mm, 13.2-100Hz @ 7m/s ² per IEC 60945-8.7
Rain and Spray	12.5mm Nozzle @ 100liters/min from 3m for 30min per IEC 60945-8.8
Solar Radiation	Ultraviolet B, A, Visible, and Infrared per IEC 60945-8.10
Corrosion (Salt Mist)	4 times 7days @ 40°C, 95%RH after 2 hour Salt Spray Per IEC 60945-8.12
Electromagnetic Immunity	Conducted, Radiated, Supply, and ESD per IEC 60945-10
Safety Precautions	Dangerous Voltage, Electromagnetic Radio Frequency per IEC 60945-12



Navigation Instruments

GPS200 - GPS Antenna/Receiver

WS0100 - Ultrasonic Wind and Weather Station

SSC300 - Solid State Compass

DST110 - Depth/Speed/Temperature Triducer

Maretron brings you state-of-the-art, award-winning navigation instruments. Take our compass, for example. We were the first to bring solid-state compass technology to the marine industry, resulting in superior accuracy and incredible response time. The result – rock solid radar overlay on your charting software and unprecedented autopilot performance. Our ultrasonic wind/weather station is another example of award-winning technology – no moving parts and built from the ground up for the marine industry. Aerodynamically designed for accurate wind speed and direction even when the boat is heeled over in pitching and rolling seas. And of course, all our navigation instruments are engineered to the highest international marine standard (IEC 60945) for years of reliable service.



SAIL honors Freeman K. Pittman's memory with its annual FKP Awards, which recognize the finest and most innovative new products on the market—the very stuff that Freeman sought out during his tenure at the magazine.



The NMMA Innovation Awards are presented each year at the Miami Boat Show and they recognize products that exhibit innovative distinction from other products, benefit to the marine industry and/or consumer, practicality, and cost-effectiveness.



GPS200
GPS Antenna/Receiver



WS0100
Ultrasonic Wind and Weather Station



SSC300
Solid State Compass



DST110
Depth/Speed/Temperature Triducer



GPS200 *GPS Antenna/ Receiver*

Maretron's GPS200 is a state-of-the-art GPS/GLONASS antenna and receiver capable of producing ten position fixes per second. The GPS200 has unprecedented sensitivity and can even be mounted underneath a fiberglass deck. An additional benefit of the GPS200 is that it broadcasts precision magnetic variation information using the current position and world magnetic model (WMM2015).

The GPS200 antenna/receiver is a plug-and-play device that is fully compliant and certified to the NMEA 2000® Standard. It will directly connect to any NMEA 2000® network and communicate with navigational software, chart plotters, autopilots and dedicated instrument displays – such as Maretron's DSM150 or DSM250 graphical display – and its compact, waterproof housing provides years of reliable performance.



The GPS200 automatically decodes GPS correction signals from Satellite Based Augmentation Systems (SBAS) including the North American Wide Area Augmentation System (WAAS), the European Geostationary Navigation Overlay System (EGNOS), or the Asian Multifunctional Transport Satellite-based Augmentation System (MSAS) to provide better than 2.5m accuracy.

The GPS200 is easily mounted to a standard marine mount with 1"-14 TPI male pipe end. It can also be mounted directly to a deck.

Products

PART NUMBER	DESCRIPTION
GPS200-01	GPS Antenna/Receiver

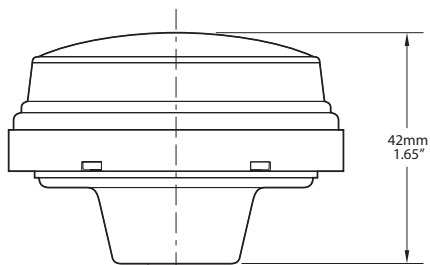

1" - 14 - UNS-2B Thread
(1" - 14 TPI Standard Marine Mount)

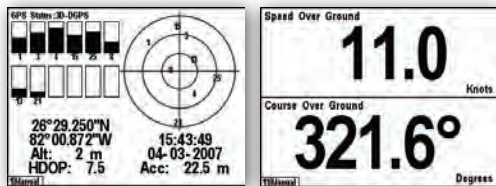
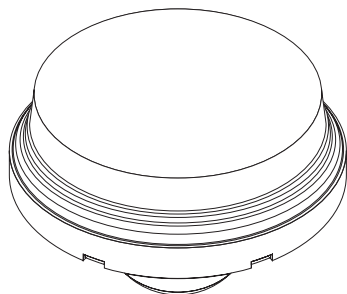
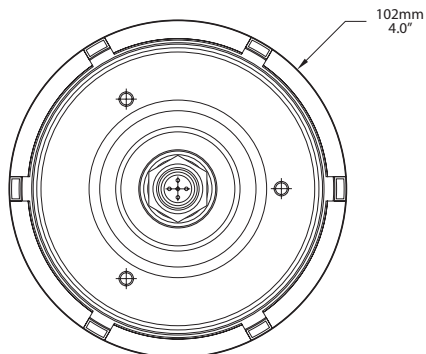

DSM150 & DSM250 Screen Shots

Specifications

Parameter	Value	Comment
Supported Positioning Systems	GPS, GLONASS	Simultaneously
Position Accuracy (Autonomous)	<3m	2D RMS
Position Accuracy (WAAS)	<2.5m	2D RMS (depends on accuracy of correction data)
Channels	99	33 Tracking, 99 Acquisition
Tracking Sensitivity	-161dBm	
Position Update Rate	10 per Second	10 Hz Position Fix Calculation Rate
Speed Update Rate	10 per Second	
Time Update Rate	1 per Second	
Hot Start	1 Seconds	Start Within Hours of Last Power Down
Cold Start	33 Seconds	Start from Unknown Position
Satellite Based Augmentation System	WAAS	North America
	EGNOS	Europe
	MSAS	Asia
	GAGAN	India
Altitude Limit	□18000 m	
Velocity Limit	□515 m/sec	
Battery Backup	Lithium (4-5 Days)	Holds Position for Hot Starts

Certifications

Standard	Comment
NMEA 2000®	Level A
Maritime Navigation and Radiocommunication Equipment & Systems	Tested to IEC 60945
FCC and CE Mark	Electromagnetic Compatibility

NMEA 2000® Parameter Group Numbers (PGNs)

Description	PGN #	PGN Name	Default Rate
Periodic Data PGNs	126992	System Time	1 Time/Second
	128259	Speed	Disabled
	129025	Position, Rapid Update	5 Times/Second
	129026	COG and SOG, Rapid Update	4 Times/Second
	129029	GNSS Position Data	1 Time/Second
	129539	GNSS DOPs	1 Time/Second
	129540	GNSS Satellites in View	1 Time/Second
	127258	Magnetic Variation	1 Time/Second
	Response to Requested PGNs	126464	PGN List (Transmit and Receive)
126996		Product Information	N/A
126998		Configuration Information	N/A
129538		GNSS Control Status	N/A
129541		GPS Almanac Data	N/A
059392		ISO Acknowledge	N/A
Protocol PGNs	059904	ISO Request	N/A
	060416	ISO Transport Protocol, Connection Management	N/A
	060160	ISO Transport Protocol, Data Transfer	N/A
	060928	ISO Address Claim	N/A
	065240	ISO Address Command	N/A
	126208	NMEA	N/A

Electrical

Parameter	Value	Comment
Operating Voltage	9 to 32 Volts	DC Voltage
Power Consumption	<100mA	Average Current Drain
Load Equivalence Number (LEN)	2	NMEA 2000® Spec. (LEN = 50 mA)
Reverse Battery Protection	Yes	Indefinitely
Load Dump Protection	Yes	Energy Rated per SAE J1113

Mechanical

Parameter	Value	Comment
Size	4" Diameter x 1.65" Tall	Not Including Antenna Mount Base
Weight	6 oz.	Not Including Antenna Mount Base
Mounting	Deck or Pole	Fits 1"-14 TPI Standard Marine Mount

Environmental

Parameter	Value
IEC 60945 Classification	Exposed
Degree of Protection	IP67
Operating Temperature	-25°C to 55°C
Storage Temperature	-40°C to 70°C
Relative Humidity	93%RH @40° per IEC60945-8.2
Vibration	2-13.2Hz @ ±1mm, 13.2-100Hz @ 7m/s² per IEC 60945-8.7
Rain and Spray	12.5mm Nozzle @ 100liters/min from 3m for 30min per IEC 60945-8.8
Solar Radiation	Ultraviolet B, A, Visible, and Infrared per IEC 60945-8.10
Corrosion (Salt Mist)	4 times 7days @ 40°C, 95%RH after 2 hour Salt Spray Per IEC 60945-8.12
Electromagnetic Emission	Conducted and Radiated Emission per IEC 60945-9
Electromagnetic Immunity	Conducted, Radiated, Supply, and ESD per IEC 60945-10
Safety Precautions	Dangerous Voltage, Electromagnetic Radio Frequency per IEC 60945-12



WSO100 *Ultrasonic Wind and Weather Station*

Maretron's outdoor weather station measures wind speed and direction, air temperature, barometric pressure, and relative humidity. The wind measurement is performed using ultrasonic sensors, which means there are no moving parts to wear out or to get caught in the rigging.

The WSO100 accurately measures wind speed and direction even when tilted, making it ideally suited for heeled sailboats or powerboats operating in pitching and rolling seaways.

When used with Maretron displays (DSM150, DSM250, N2KView®), you can view apparent wind speed and direction, humidity, air temperature, barometric pressure (with graphs to see trends), wind chill factor, heat index, and dew point. If you add speed through water (DST110), GPS (GPS200) and compass (SSC300), you can view true vessel referenced wind speed and direction as well as ground referenced speed and direction.



The WSO100 provides these functions:

- Apparent Wind Speed
- Apparent Wind Direction
- Atmospheric Pressure
- Air Temperature
- Relative Humidity

Products

PART NUMBER	DESCRIPTION
WSO100-01	Ultrasonic Wind/Weather Station



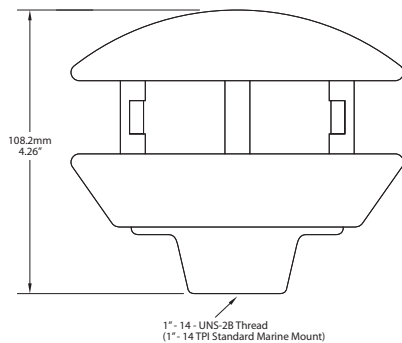

1" - 14 - UNS-2B Thread
(1" - 14 TPI Standard Marine Mount)

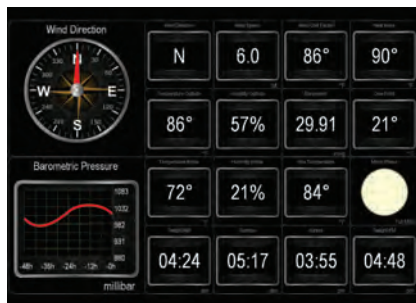
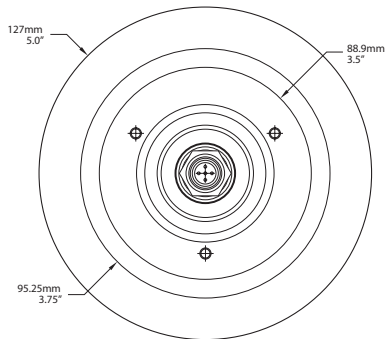

N2KView Environment Screen

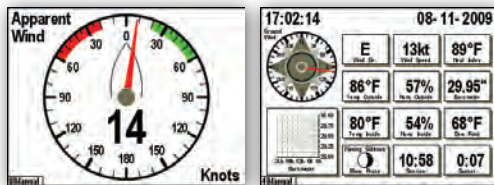

DSM150 & DSM250 Screen Shots

Specifications

Parameter	Value	Comment
Wind Speed Range	0.5 to 99.5 knots (1 to 185 kph)	
Wind Speed Resolution	0.1 knot (0.19 kph)	
Wind Speed Accuracy	± 5% or 1 knot (1.9 kph)	Tilt 0° (operates to 30° tilt)
Wind Direction Accuracy	± 5°	Tilt 0° (operates to 30° tilt)
Temperature Range	-25° to 55° C	
Temperature Resolution	0.1°F (0.06°C)	
Temperature Accuracy	± 1.8°F (1°C)	
Relative Humidity Range	0-99% RH	
Relative Humidity Resolution	1% RH	
Relative Humidity Accuracy	± 4% RH	0% to 80% RH 80% to 99% RH
Barometric Pressure Range	26 to 32" Hg (880 to 1080 mb)	
Barometric Pressure Resolution	0.03" Hg (1 mb)	
Barometric Pressure Accuracy	± 0.1" Hg (± 3.4 mb)	

Certifications

Standard	Comment
NMEA 2000® Standard	Level A
Maritime Navigation and Radio Communication Equipment & Systems	IEC 61162-3
Maritime Navigation and Radio Communication Equipment & Systems	IEC 60945
FCC and CE mark	Electromagnetic Compatibility

NMEA 2000® Parameter Group Numbers (PGNs)

Description	PGN #	PGN Name	Default Rate
Periodic Data PGNs	130306	Wind Data	10 Times/Second
	130310	Environmental Parameters	10 Times/Second
	130311	Environmental Parameters	2 Times/Second
	130312	Temperature	2 Times/Second
	130313	Humidity	2 Times/Second
	130314	Actual Pressure	2 Times/Second
Response to Requested PGNs	126464	PGN List (Transmit and Receive)	N/A
	126996	Product Information	N/A
	126998	Configuration Information	N/A
Protocol PGNs	059392	ISO Acknowledge	N/A
	059904	ISO Request	N/A
	060416	ISO Transport Protocol, Connection Management	N/A
	060160	ISO Transport Protocol, Data Transfer	N/A
	060928	ISO Address Claim	N/A
	065240	ISO Address Command	N/A
	126208	NMEA Complex Request/Command/Ack.	N/A
Maretron Proprietary PGNs	126720	Configuration	N/A

Electrical

Parameter	Value	Comment
Operating Voltage	9 to 16 Volts	DC Voltage
Power Consumption	<150mA	Average Current Drain
Load Equivalence Number (LEN)	3	NMEA 2000® Spec. (1LEN = 50 mA)
Reverse Battery Protection	Yes	Indefinitely
Load Dump Protection	Yes	Energy Rated per SAE J1113

Mechanical

Parameter	Value	Comment
Size	4.25" Dia. x 3.45" Tall (108mm Dia. x 88mm Tall)	Including Mounting Bracket
Weight	10 oz. (283g)	Including Mounting Bracket
Mounting	Pole	Fits 1"-14 TPI Standard Marine Mount

Environmental

Parameter	Value
IEC 60945 Classification	Exposed
Degree of Protection	IP67
Operating Temperature	-25°C to 55°C
Storage Temperature	-40°C to 70°C
Relative Humidity	93%RH @40° per IEC60945-8.2
Vibration	2-13.2Hz @ ±1mm, 13.2-100Hz @ 7m/s² per IEC 60945-8.7
Rain and Spray	12.5mm Nozzle @ 100liters/min from 3m for 30min per IEC 60945-8.8
Solar Radiation	Ultraviolet B, A, Visible, and Infrared per IEC 60945-8.10
Corrosion (Salt Mist)	4 times 7days @ 40°C, 95%RH after 2 hour Salt Spray Per IEC 60945-8.12
Electromagnetic Emission	Conducted and Radiated Emission per IEC 60945-9
Electromagnetic Immunity	Conducted, Radiated, Supply, and ESD per IEC 60945-10
Safety Precautions	Dangerous Voltage, Electromagnetic Radio Frequency per IEC 60945-12



SSC300 *Solid State Compass*

Maretron's SSC300, implementing the second generation of Maretron's award-winning solid state compass technology, is a solid state, rate gyro electronic compass that provides better than 0.7° heading accuracy through $\pm 45^\circ$ of roll and pitch angle, and better than 1° roll and pitch accuracy in static conditions. Each SSC300 is factory calibrated for maximum accuracy. It delivers precise, reliable heading and rate of turn information ten times per second, and vessel attitude including pitch and roll readings once per second. A micromachined 3-axis rate gyro is used in conjunction with the 3-axis accelerometer by advanced stabilization algorithms to provide accurate, stable readings during dynamically changing conditions such as hard turns or rough seas, making it an ideal heading sensor for autopilot or radar overlay applications.

Maretron's SSC300 is certified to the NMEA 2000® network standard and compatible with the NMEA 0183 digital interface standard. It connects directly with any NMEA 2000® network, and, with the optional NMEA 0183 cable accessory, with NMEA 0183 listeners to share information with navigational software, chart plotters, autopilots, and dedicated instrument displays – including Maretron's graphical displays and N2KView® software.



Products

PART NUMBER	DESCRIPTION
SSC300-01	Solid-State Rate/Gyro Compass (No NMEA 0183 Cable)
MARE-006	SSC300 Compass NMEA 0183 10 meter Connection Cable

- Better than 0.7° heading accuracy in status conditions
- Better than 1.5° heading accuracy in dynamic conditions
- Better than 1°/second rate of turn accuracy
- Better than 1° pitch/roll accuracy
- Three-axis magnetometer, Three-axis rate gyro, and Three-axis accelerometer
- Outputs NMEA 0183 and NMEA 2000 data simultaneously (optional NMEA 0183 cable accessory required for NMEA 0183 output)
- IP67 waterproof enclosure



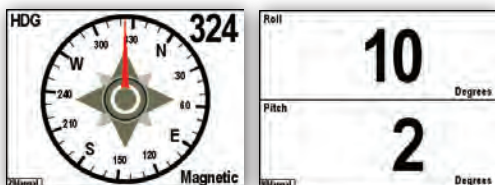
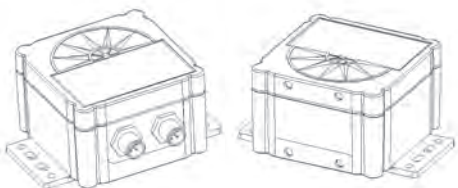
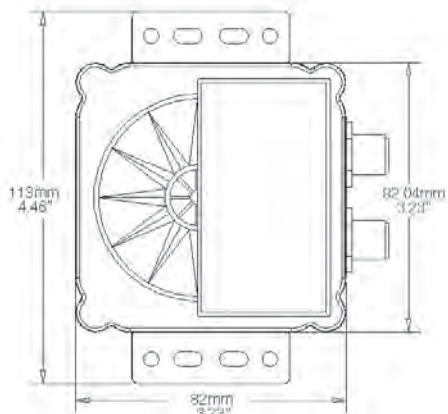

DSM150 & DSM250 Screen Shots

Specifications

Parameter	Value	Comment
Static Heading Accuracy	<0.7° RMS	±45° Pitch and Roll - 15°C to 35°C
Heading Display Resolution	0.1°	With Maretron Display
Setting Time	1 Second	To Static Accuracy after 35°/Second Turn
Heading Update Rate	10 per Second	
Heading Deviation	Yes	Automatic
Alignment Calibration	Yes	In Boat Calibration with Maretron Displays
Pitch and Roll Range	±80°	With Maretron Display
Pitch and Roll Accuracy	<1°	±45° Pitch and Roll - 15°C to 35°C
Pitch and Roll Display Resolution	0.1°	With Maretron Display
Pitch and Roll Update Rate	1 per Second	
Pitch and Roll to Boat Alignment	Yes	In Boat Calibration with Maretron Displays
Rate of Turn Range	0° - 90°/ Second	At 0° Pitch and Roll
Rate of Turn Accuracy	±1° per Second	0° Pitch and Roll - 15°C to 35°C
Rate of Turn Update Rate	10 per Second	
NMEA 0183 Standard	Compatible	Up to 38,400 Baud (40 Hz Update Rate)

Certifications

Standard	Comment
NMEA 2000® Standard	Level A
Maritime Navigation and Radio Communication Equipment & Systems	IEC 61162-3
Maritime Navigation and Radio Communication Equipment & Systems	IEC 60945
FCC and CE mark	Electromagnetic Compatibility

NMEA 2000® Parameter Group Numbers (PGNs)

Description	PGN #	PGN Name	Default Rate
Periodic Data PGNs	127250	Vessel Heading	10 Times/Second
	127257	Attitude	1 Time/Second
	127251	Rate of Turn	10 Times/Second
Response to Requested PGNs	126464	PGN List (Transmit and Receive)	N/A
	126996	Product Information	N/A
	126998	Configuration Information	N/A
Protocol PGNs	059392	ISO Acknowledge	N/A
	059904	ISO Request	N/A
	060416	ISO Transport Protocol, Connection Management	N/A
	060160	ISO Transport Protocol, Data Transfer	N/A
	060928	ISO Address Claim	N/A
	065240	ISO Address Command	N/A
	126208	NMEA Request/Command/Acknowledge	N/A
Maretron Proprietary PGNs	126720	Configuration	N/A

NMEA 0183 Sentences

Sentence	Acronym	Sentence Name	Description
Transmitted Sentences	HDG	Heading, Deviation, and Variation	10 Times/Second
	HDM	Heading, Magnetic	N/A
	HDT	Heading, True	N/A
	ROT	Rate of Turn	5 Times/Second
	PMAROUT	Maretron Proprietary Attitude (Pitch and Roll)	1 Time/Second
Received Sentences	TXT	Text Transmission	N/A
	RMC	Recommended Minimum Specific GNSS Data	N/A
	VTG	Course Over Ground and Ground Speed	N/A

Environmental Mechanical Electrical

Parameter	Value	Comment
Operating Voltage	9 to 16 Volts	DC Voltage
Power Consumption	< 150mA	Average Current Drain
Load Equivalence Number (LEN)	3	NMEA 2000® Spec. (1 LEN = 50mA)
Reverse Battery Protection	Yes	Indefinitely
Load Dump Protection	Yes	Energy Rated Per SAE J1113

Parameter	Value	Comment
Size	4.46" x 3.23 x 2.14" (113mm x 82mm x 54mm)	Including Mounting Flanges
Weight	7 Oz. (198 g)	Including Mounting Bracket
Mounting	Deck or Bulkhead	

Parameter	Value
IEC 60945 Classification	Exposed
Degree of Protection	IP67
Operating Temperature	-25°C to 55°C
Storage Temperature	-40°C to 70°C
Relative Humidity	93%RH @40° per IEC60945-8.2
Vibration	2-13.2Hz @ ±1mm, 13.2-100Hz @ 7m/s² per IEC 60945-8.7
Rain and Spray	12.5mm Nozzle @ 100liters/min from 3m for 30min per IEC 60945-8.8
Solar Radiation	Ultraviolet B, A, Visible, and Infrared per IEC 60945-8.10
Corrosion (Salt Mist)	4 times 7days @ 40°C, 95%RH after 2 hour Salt Spray Per IEC 60945-8.12
Electromagnetic Immunity	Conducted, Radiated, Supply, and ESD per IEC 60945-10
Safety Precautions	Dangerous Voltage, Electromagnetic Radio Frequency per IEC 60945-12



DST110 *Depth/Speed/ Temperature Triducer*

Maretron's DST110 Smart™ Retractable Depth/Speed/Temperature Transducer delivers precise digital depth, accurate speed and exact water temperature even at speeds above 40 knots.

Its patented Smart™ Sensor technology, retractable and removable sensor, and NMEA 2000® network connectivity make the DST110 easy to interpret, easy to install and connect with other navigation equipment, and easy to maintain.

The DST110 measures precise water depth at 0.4m to 100m with a wide beam width and is tolerant to most deadrise angles. It reads water temperature from -10°C to +40°C at ±1.0°C accuracy and accurate speed from 1 to 50 knots. User customizable calibrations for speed and temperature allow you to adjust speed and temperature indications for your installation. At 235 kHz, it can be used with a fish finder as an ideal navigation tool for sport or commercial fishing vessels or with sailing vessels of all sizes.

Products

PART NUMBER	DESCRIPTION
DST110-01	Depth/Speed/Temperature Triducer® (100 Meter Depth)
M33-100	Bronze Housing Kit for DST100/DST110
33-398-04PW	Spare Paddle Wheel Kit

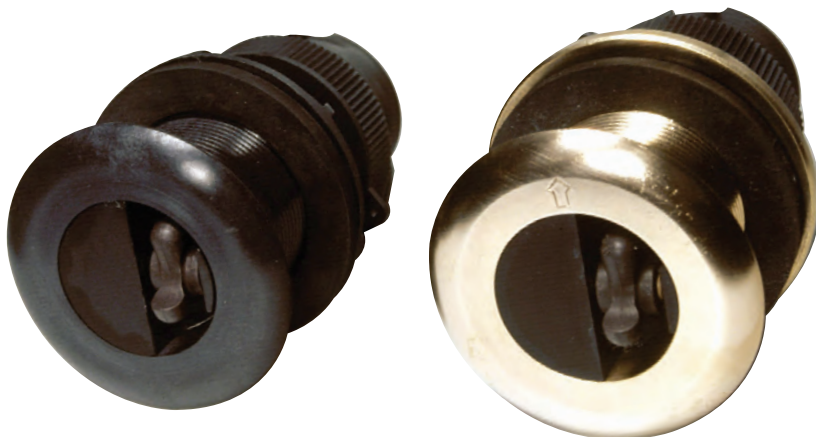

The DST110's plastic or bronze choices are compatible with any hull material. It includes a blank plug to replace its sensor unit when the vessel will be docked for extended periods or tailored. This prevents damage to the sensor and reduces fouling growth.

Maretron's DST110 is CE compliant (IEC 60945) and is manufactured to the highest quality standards under ISO9K/2K procedures. Its compact, waterproof housing will provide years of reliable performance, making it the Smart™ choice in marine sensing.

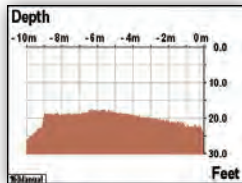
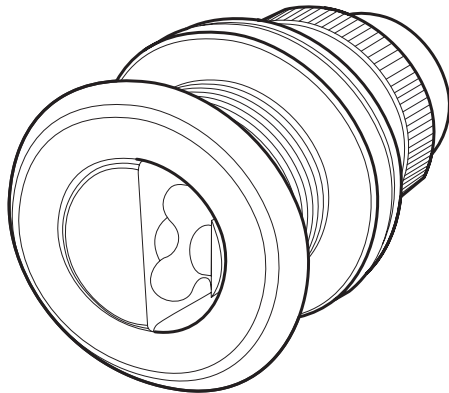
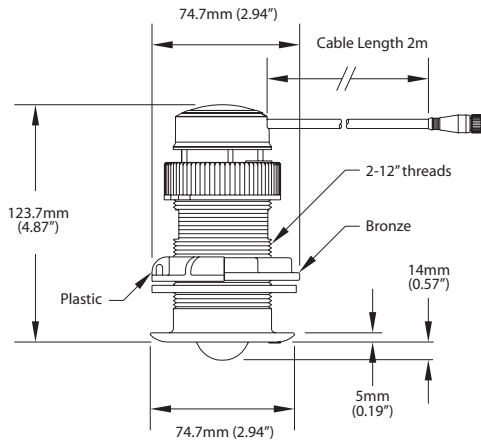

DSM150 or DSM250 Screen Shots



Copyright 2017 Maretron, LLP. All rights reserved. As Maretron is constantly improving its products, all specifications are subject to change without notice. Maretron's products are designed to be accurate and reliable; however, they should be used only as aids to navigation and vessel monitoring, and not as a replacement for traditional navigation and vessel monitoring techniques. A prudent captain or navigator never relies on a single source for navigation or system monitoring information. "NMEA 2000" is a registered trademark of the National Marine Electronics Association.

Specifications

Parameter	Value	Comment
Depth Operating Frequency	235 kHz	Wide Beam Angle
Beam Width	10° x 44°	
Minimum Depth	0.4 meters	Deadrise Angle Tolerant
Maximum Depth	100 meters	No Calibration Required
Depth Accuracy	±20cm	0.6 – 7 meters
	±3%	7 – 100 meters
Depth Tracking Speeds	Up to 50 knots	High Speed Bottom Tracking Capability
Depth Update Rate	1 second	
Transmission Power	100 Watts	2% Duty Cycle
Speed Sensor	Paddlewheel	
Speed Range	1 – 50 knots	Microprocessor Signal Processing Accuracy
Speed Update Rate	1 second	
Water Temperature Range	-10°C to 40°C	Fast Response Time
Water Temperature Accuracy	±1.0°C	No Calibration Required
Water Temperature Resolution	0.01°C	
Deadrise Angle	≤22°	

Certifications

Standard	Comment
NMEA 2000® Standard	Level B+
Maritime Navigation and Radiocommunication Equipment & Systems	IEC 61162-3
Maritime Navigation and Radiocommunication Equipment & Systems	IEC 60945
FCC and CE Mark	Electromagnetic Compatibility

NMEA 2000® Parameter Group Numbers (PGNs)

Description	PGN#	PGN Name	Default Rate
Periodic Data PGNs	128267	Water Depth	1 Time/Second
	128259	Speed (Water Referenced)	1 Time/Second
	130310	Environmental Parameters (Water Temperature)	2 Times/Second
	130311	Environmental Parameters (Water Temperature)	2 Times/Second
	130312	Temperature	0.5 Times/Second
	128275	Distance Log	1 Time/Second
Response to Requested PGNs	126464	PGN List (Transmit and Receive)	N/A
	126996	Product Information	N/A
	126998	Configuration Information	N/A
Protocol PGNs	059392	ISO Acknowledge	N/A
	059904	ISO Request	N/A
	060928	ISO Address Claim	N/A
	065240	ISO Address Command	N/A
	126208	NMEA Request/Command/Acknowledge	N/A

Electrical

Parameter	Value	Comment
Operating Voltage	9 to 32 Volts	DC Voltage
Power Consumption	<200mA	Average Current Drain
Load Equivalence Number (LEN)	4	NMEA 2000® Spec. (1LEN = 50 mA)
Reverse Battery Protection	Yes	Indefinitely

Mechanical

Parameter	Value	Comment
Size	2.94" Dia. X 4.87" Tall (74.7 Dia. X 123.7mm Tall)	Including Mounting Flanges
Weight	12 Oz. (340 g)	
Mounting	Lexan/Bronze/Stainless Steel	Bronze/Stainless Steel Optional
Hole Diameter for Mounting	2" (51 mm)	

Environmental

Parameter	Value
IEC 60945 Classification	Submerged
Degree of Protection	IP 68
Operating Temperature	-10°C to 40°C
Storage Temperature	-30°C to 70°C
Vibration	2-13.2Hz @ ±1mm, 13.2-100Hz @ 7m/s² per IEC 60945-8.7
Water Immersion	per IEC 60945-8.9
Corrosion (Salt Mist)	4 times 7days @ 40°C, 95%RH after 2 hour Salt Spray Per IEC 60945-8.12
Electromagnetic Emission	Conducted and Radiated Emission per IEC 60945-9
Electromagnetic Immunity	Conducted, Radiated, Supply, and ESD per IEC 60945-10

Maretron NMEA 2000®

Cables & Connectors

About NMEA 2000® Cables and Connectors

The NMEA 2000® standard goes beyond defining message content and includes requirements for the cabling used to interconnect electronic components (referred to as the physical interface). The following catalog pages contain the NMEA 2000® approved network interconnect components used to build an operational network.

About Micro, Mid and Mini Cable Systems

There are three types of NMEA 2000® cabling systems, Micro, Mid and Mini. The Micro/Mid cable system is generally used for smaller networks requiring less power (i.e., less than 4 amps per network leg) while the Mini cable system is used for larger networks (i.e., more than 4 amps but less than 8 amps per leg).

Micro/Mid NMEA 2000® Network Example

(Up to 4 amps per leg)

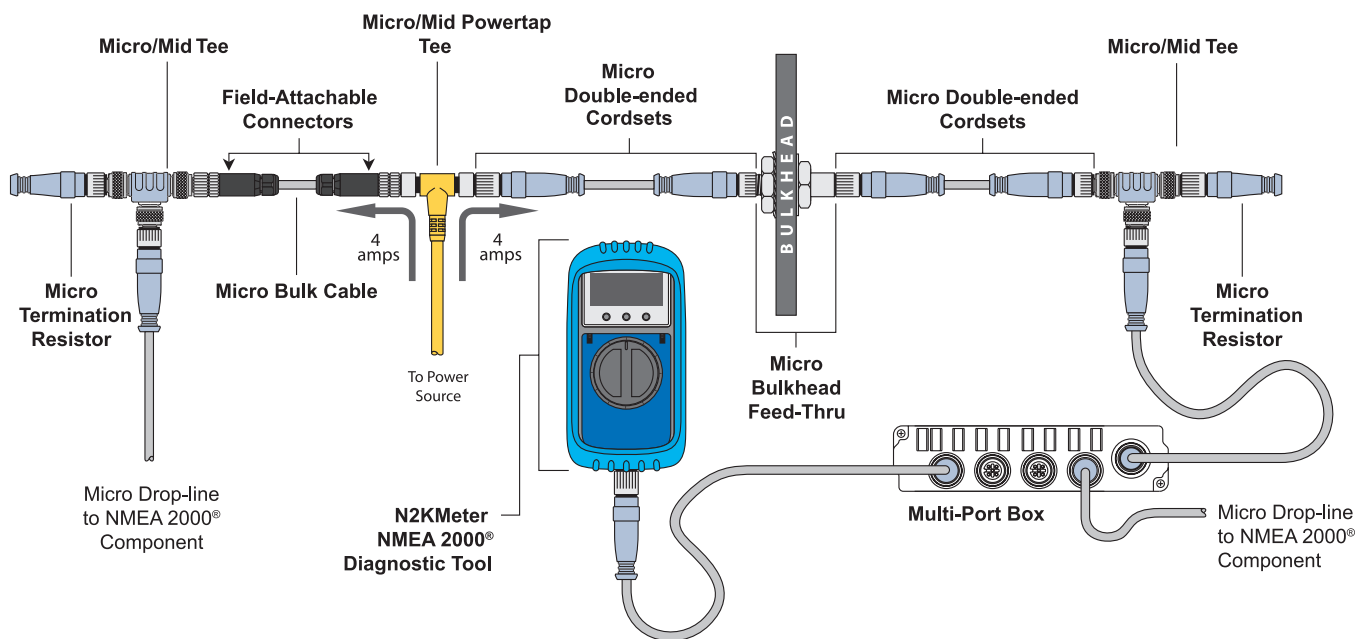

Micro Bulk Cable



Micro bulk cable is primarily used as drop cable, but it can also be used at the trunk line depending on network power requirements. Bulk cable with field-attachable connectors allows for maximum flexibility as cables can be made on the job to exact lengths.

- Meets and exceeds NMEA 2000® specifications for the highest reliability
- Trunk or drop cable for use with Micro connectors
- Used with field-attachable connectors to build exact length cables at the job site

Micro/Mid Field-Attachable Connectors (Straight – Male/Female)



Field-attachable connectors allow you to make field connections to bulk cable (see diagram). The color-coded screw terminals match the individual wire colors found within the bulk cable for error-free field installation.

- Color-coded screw terminals make for error-free field installation
- Rugged housing material designed to withstand harsh marine environments

Micro/Mid Field-Attachable Connectors (90° Male/Female)



Like the straight Micro/Mid Field-attachable Connectors, the 90° field attachable connectors allow you to make field connections to bulk cable. The 90° connectors are particularly well suited for tight spaces like the back of displays where there is limited space for a straight connector.

- Useful in tight spaces or where sharp corners need to be made
- Waterproof rated to IP67

Copyright 2017 Maretron, LLP. All rights reserved. As Maretron is constantly improving its products, all specifications are subject to change without notice. Maretron's products are designed to be accurate and reliable; however, they should be used only as aids to navigation and vessel monitoring, and not as a replacement for traditional navigation and vessel monitoring techniques. A prudent captain or navigator never relies on a single source for navigation or system monitoring information. "NMEA 2000" is a registered trademark of the National Marine Electronics Association.

Micro Bulk Cable

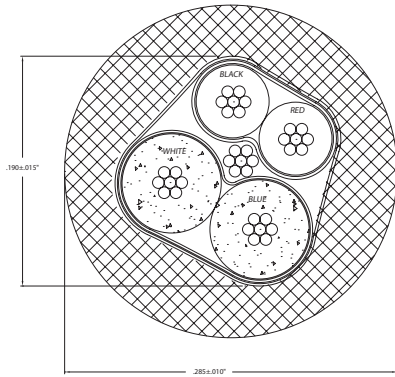

Specifications

OVERALL	
Outer Jacket Mat/Color:	PVC/Gray
Insulation Material:	PE (data wires), SRPVC (power wires)
Construction:	4x22 (0.65mm) AWG, 22 (0.65mm) AWG Drain
Shielding (3 Levels):	FOIL (overall), FOIL (power pair), FOIL (data pair)
POWER PAIR	
Wire:	2X22 (0.65mm) AWG
Resistance/Conductor:	18.1 Ohms/1000ft
Max Amperage:	6 Amps
Color Code:	Red/Black
DATA PAIR	
Wire:	2X22 (0.65mm) (AWG)
Characteristic Impedance:	120 Ohms ± 10%
Capacitance:	11.33pF/ft ± 10%
Color Code:	White/Blue
APPROVALS	
UL:	PLTC 75°C Sunlight Resistant E90625, AWM 80°C 300V
CSA:	CMX-OUTDOOR-CMG LL54185 75°C, AWM III A/B 80C 300V FT4
NMEA:	NMEA 2000® Approved
IEC:	IEC-61162-3

Products

PART NUMBER	DESCRIPTION
CG1	Micro Bulk Cable (per meter – gray) (no spool)
CG1-100	Micro Bulk Cable (Two Pieces per 100m spool – gray)
CG1-100C	Micro Bulk Cable (Single Piece per 100m spool – gray)

Micro/Mid Field-Attachable Connectors (Straight)

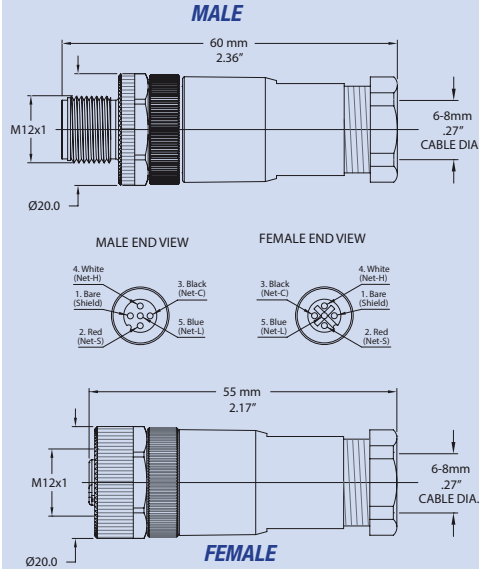

Specifications

MECHANICAL	
Housing Mat/Plating:	Nylon/Black
Contact Mat/Plating:	Brass/Gold
Coupling Nut Mat/Plating:	Brass/Nickel
Maximum Wire Size:	18 (1.02mm) AWG
Cable Grip Range:	6-8 mm
ELECTRICAL	
Rated Current:	4.0 Amps
Rated Voltage:	30 V AC/ 36 V DC
ENVIRONMENTAL	
Protection Class:	IEC IP67
Temperature Range:	-40°C TO 85°C (-40°F to 185°F)
APPROVALS	
NMEA:	NMEA 2000® Approved
IEC:	IEC-61162-3

Products

PART NUMBER	DESCRIPTION
FA-CF-ST	Micro/Mid Field Attachable Connector (Straight Female)
FA-CM-ST	Micro/Mid Field Attachable Connector (Straight Male)

Micro/Mid Field-Attachable Connectors (90°)

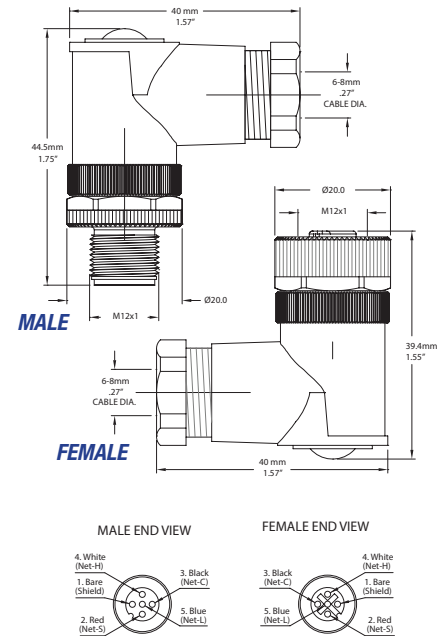

Specifications

MECHANICAL	
Housing Mat/Plating:	Nylon/Black
Contact Mat/Plating:	Brass/Optaloy
Coupling Nut Mat/Plating:	Brass/Nickel
Maximum Wire Size:	18 (1.02mm) AWG
Cable Grip Range:	6-8 mm
ELECTRICAL	
Rated Current:	4.0 Amps
Rated Voltage:	30 V AC/ 36 V DC
ENVIRONMENTAL	
Protection Class:	IEC IP67
Temperature Range:	-40°C TO 85°C (-40°F to 185°F)
APPROVALS	
NMEA:	NMEA 2000® Approved
IEC:	IEC-61162-3

Products

PART NUMBER	DESCRIPTION
FA-CF-90	Micro/Mid Field Attachable Connector (90° Female)
FA-CM-90	Micro/Mid Field Attachable Connector (90° Male)

Micro Double-Ended Cordsets



Double-ended cordsets are used for trunk or drop lines and make for a secure connection and simple timesaving installation. The connectors are keyed for error-free connection and they are waterproof for continued operation even while submerged in the bilge.

- Rugged, IP68 rated connectors for continued connection integrity in marine environments
- Various cable lengths to match installation requirements

Micro Tee



A Tee is used to tap into the trunk line for adding a drop connection. The standard tee is also available with a cap for a protected diagnostic connection. Tees can be mated with all other devices on the network of the same connector style.

- Gold contacts for greatest reliability
- Keyed connectors for error-free connections

Micro/Mid Powertap Tee



A Powertap Tee is connected to a network backbone just like any Tee but rather than connecting a device their purpose is to provide “bus” power. Maretron Powertap Tee uniquely provides two power inputs permitting doubled power provision for devices.

- Yellow cable indicates power and can't be confused with gray network cable
- Two cable lengths to match installation requirements

Copyright 2017 Maretron, LLP. All rights reserved. As Maretron is constantly improving its products, all specifications are subject to change without notice. Maretron's products are designed to be accurate and reliable; however, they should be used only as aids to navigation and vessel monitoring, and not as a replacement for traditional navigation and vessel monitoring techniques. A prudent captain or navigator never relies on a single source for navigation or system monitoring information. "NMEA 2000" is a registered trademark of the National Marine Electronics Association.

Micro Double-Ended Cordsets

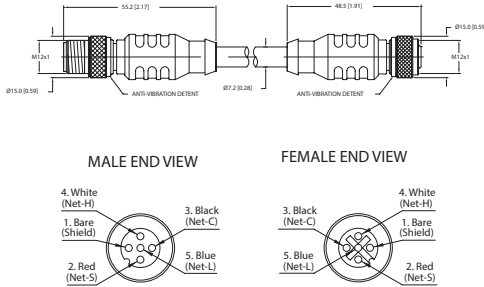

Specifications

MECHANICAL	
Contact Carrier Mat/Color:	Thermoplastic PUR/Blue-Gray
Molded Body Mat/Color:	Thermoplastic PUR/Blue-Gray
Contact Mat/Plating:	Brass/Gold
Coupling Nut Mat/Plating:	Brass/Nickel
Connector Outside Diameter:	0.59"
ELECTRICAL	
Current Rating:	4.0 Amps
Voltage Rating:	250 V
CABLE	
Outer Jacket Mat/Color:	PVC/Gray
Conductor Insulation Material:	HDPE (data pair), SRPVC (power pair)
Number of Conductors:	4X22 AWG, 22 AWG Drain Wire
Shielding (3-Levels):	FOIL (Overall), FOIL (Power Pair), FOIL (Data Pair)
ENVIRONMENTAL	
Protection Class:	IEC IP68, NEMA 1,3,4,6P
Temperature Rating:	-40°C to 80°C to (-40°F to 176°F)
APPROVALS	
(Cable) UL:	PLTC 75°C Sunlight Resistant E90625, AWM 80°C 300V
(Cable) CSA:	CMX-OUTDOOR-CMG LL54185 75°C, AWM I/II A/B 80C 300V FT4
NMEA:	NMEA 2000® Approved
IEC:	IEC 61162-3

Products

PART NUMBER	DESCRIPTION
CM-CG1-CF-00.5	Micro Double-Ended Cordset - M to F - 0.5M (gray)
CM-CG1-CF-01.0	Micro Double-Ended Cordset - M to F - 1M (gray)
CM-CG1-CF-02.0	Micro Double-Ended Cordset - M to F - 2M (gray)
CM-CG1-CF-03.0	Micro Double-Ended Cordset - M to F - 3M (gray)
CM-CG1-CF-04.0	Micro Double-Ended Cordset - M to F - 4M (gray)
CM-CG1-CF-05.0	Micro Double-Ended Cordset - M to F - 5M (gray)
CM-CG1-CF-06.0	Micro Double-Ended Cordset - M to F - 6M (gray)
CM-CG1-CF-08.0	Micro Double-Ended Cordset - M to F - 8M (gray)
CM-CG1-CF-10.0	Micro Double-Ended Cordset - M to F - 10M (gray)

Micro Tee

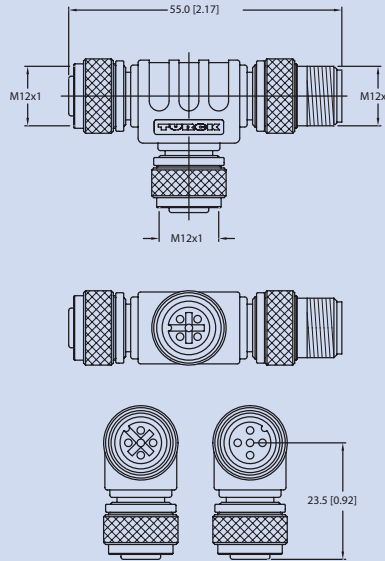

Specifications

MECHANICAL	
Molded Body Mat/Color:	Thermoplastic PUR/Blue
Contact Carrier Mat/Color:	PA 6 (Nylon)/Black
Contact Mat/Plating:	Brass/Gold
Coupling Nut Mat/Plating:	Brass/Nickel
ELECTRICAL	
Rated Current:	4.0 Amps
Rated Voltage:	60 V
ENVIRONMENTAL	
Protection Class:	IEC IP67, NEMA 1,3,4,6
Operating Temperature:	-40°C TO 80°C (-40°F to 176°F)
APPROVALS	
NMEA:	NMEA 2000® Approved
IEC:	IEC 61162-3

Products

PART NUMBER	DESCRIPTION
CM-CF-CF	Micro Tee

Micro/Mid Powertap Tees

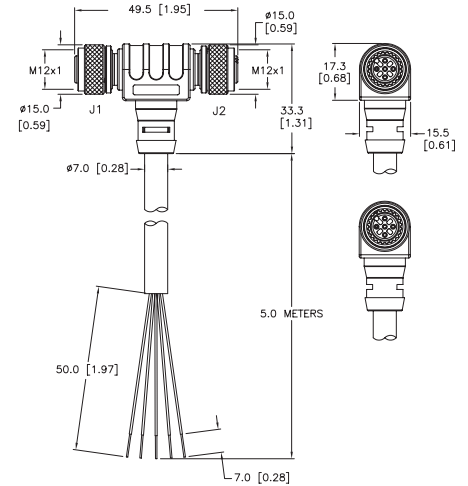

Color	Name	Usage	Connector
Blue	NET-C	Ground	J1
Brown	NET-S	Power	J1
Gray	SHIELD	Drain	J1 & J2
Black	NET-C	Ground	J2
White	NET-S	Power	J2

Specifications

MECHANICAL	
Molded Body Mat/Color:	Thermoplastic PUR/Yellow
Contact Carrier Mat/Color:	Thermoplastic PUR/Black
Contact Mat/Plating:	Brass/Gold
Coupling Nut Mat/Plating:	Brass/Nickel
Cable Jacket Mat/Color:	PVC/ Yellow
Conductor Insulation Mat:	PVC
Number of Conductors:	5x18 (1.02mm) AWG
ELECTRICAL	
Voltage Rating:	250 V
Max Amperage:	4.0 Amps
ENVIRONMENTAL	
Protection Class:	IEC IP67, NEMA 1,3,4,6P
Operating Temperature:	-40°C to 105°C (-40°F to 221°F)
APPROVALS	
NMEA:	NMEA 2000® Approved
IEC:	IEC 61162-3

Products

PART NUMBER	DESCRIPTION
CF-SPWR05-CF	Micro/Mid Powertap Tee - FM (left)/ 5 Meter 5 Wire Power drop (bottom)/FM (right)

Micro Termination Resistors



Two termination resistors are required on every NMEA 2000 network, one on each end of the trunk line. Normally, a male termination is used since male pins tend to point back to the power source. In cases where the gender is reversed, a female terminator may be required. The inline terminator is used where the network is terminated at a product, for example a GPS or weather station at the top of a mast.

- Screw terminal connector for positive connections
- Termination resistors are used to terminate both ends of the trunk line

Micro Bulkhead Feed-Thru



The Bulkhead Feed-Thru allows ease of installation through panels or bulkheads and establishes future connection points in a network installation. The bulkhead feed-thru also maintains the integrity of watertight bulkheads by providing a waterproof seal and connection.

- Features rugged keyways for positive alignment of connections
- Waterproof rated to IP67

Multiport Box (Micro/Mid Male Homerun / Micro-Mid Female Drops)



Multiport boxes allow several drop cables to be consolidated and connected back to the trunk, which eliminates the need to have numerous tees connected near a single point. Multiport boxes connect back to the trunk through a double-ended cordset and Tee.

- Ideal for consolidating many connections; for example behind dashboards
- Requires the purchase of an additional double-ended cordset for connection back to the trunk

Copyright 2017 Maretron, LLP. All rights reserved. As Maretron is constantly improving its products, all specifications are subject to change without notice. Maretron's products are designed to be accurate and reliable; however, they should be used only as aids to navigation and vessel monitoring, and not as a replacement for traditional navigation and vessel monitoring techniques. A prudent captain or navigator never relies on a single source for navigation or system monitoring information. "NMEA 2000" is a registered trademark of the National Marine Electronics Association.

Micro Termination Resistors

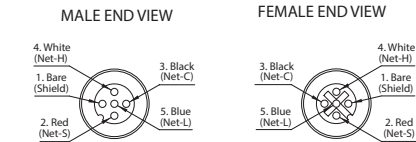
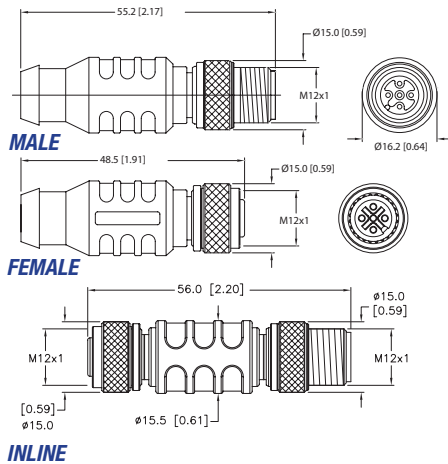

Micro Bulkhead Feed-Thru

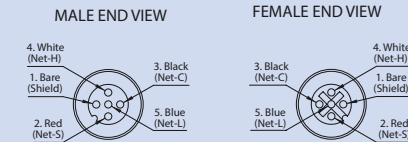
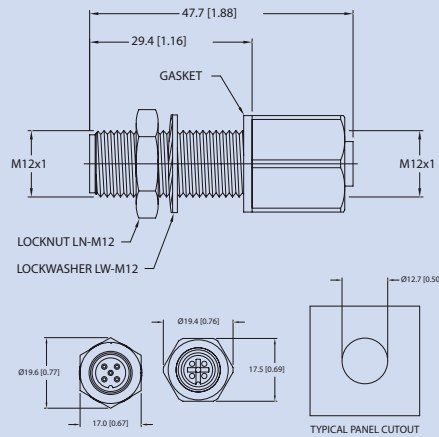

Multiport Box (Micro-Mid Male Homerun / Micro-Mid Female Drops)

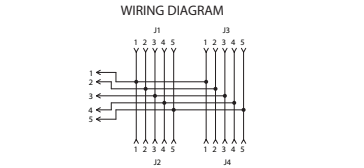
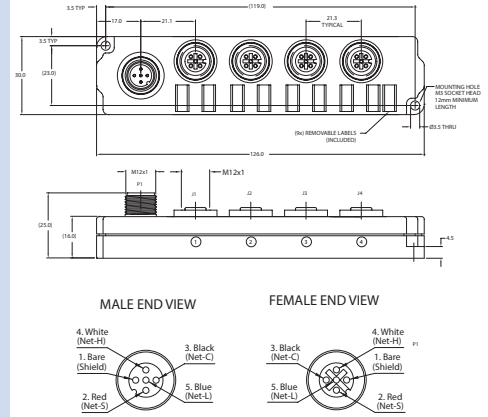

Specifications

MECHANICAL	
Molded Body Mat/Color:	Thermoplastic PUR/Blue-Gray – TR-CM, TR-CF
Contact Carrier Mat/Color:	Thermoplastic PUR/Black – IT-CM-CF
Contact Mat/Plating:	Thermoplastic PUR/Blue-Gray – TR-CM, TR-CF
Brass/Gold	Thermoplastic PUR/Black – IT-CM-CF
Coupling Nut Mat/Plating:	Brass/Nickel
ELECTRICAL	
Rated Voltage:	10-30 V DC
Internal Resistor:	120 Ohms (1/2 W) – TR-CM, TR-CF
	121 Ohms (1/4 W) – IT-CM-CF
ENVIRONMENTAL	
Protection Class:	IEC IP68, NEMA 1,3,4,6P
APPROVALS	
NMEA:	NMEA 2000 [®] APPROVED
IEC:	IEC 61162-3

Products

PART NUMBER	DESCRIPTION
TR-CM	Micro Termination Resistor (Male)
TR-CF	Micro Termination Resistor (Female)
IT-CM-CF	Micro Inline Terminator

Specifications

MECHANICAL	
Contact Carrier Mat/Color:	PA 6 (Nylon)/Blue-Gray
Contact Mat/Plating:	Brass/Gold
Housing Mat/Plating:	Brass/Nickel
Gasket Material:	Nitrile (Buna N)
Accommodates Wall (thick):	.40" (1.0 mm) to .875" (22.2 mm)
ELECTRICAL	
Voltage Rating:	250 V
Max Amperage:	4.0 Amps
Number of Conductors:	5x22 (0.65mm) AWG
ENVIRONMENTAL	
Protection Class:	IEC IP67, NEMA 1,3,4,6
Temperature Range:	-40°C to 105°C (-40°F to 221°F)
APPROVALS	
NMEA:	NMEA 2000 [®] APPROVED
IEC:	IEC 61162-3

Products

PART NUMBER	DESCRIPTION
BHF-CM-CF	Micro Bulkhead Feed-Thru

Specifications

MECHANICAL	
Housing Mat/Color:	Nylon/Blue-Gray
Receptacle Mat/Plating:	Brass/Nickel
Contact Carrier Mat/Color:	Nylon/Black
Contact Mat/Plating:	Brass/Gold
ELECTRICAL	
Operating Voltage:	250 V
Operating Current:	4.0 Amps
ENVIRONMENTAL	
Protection Class:	IP67 – when receptacles are covered
Operating Temperature:	-30°C to 80°C (-22°F to 176°F)
APPROVALS	
NMEA:	NMEA 2000 [®] Approved
IEC:	IEC 61162-3

Products

PART NUMBER	DESCRIPTION
CM-CF-4	Multiport Box (Micro-Mid Male Homerun / Micro-Mid Female Drops)

Mid Bulk Cable (Gray/Blue)



Mid bulk cable is primarily used as drop cable, but it can also be used at the trunk line depending on network power requirements. Bulk cable with field-attachable connectors allows for maximum flexibility as cables can be made on the job to exact lengths.

- Meets and exceeds NMEA 2000® specifications for the highest reliability
- Used with field-attachable connectors to build exact length cables at the job site
- Optimized for voltage drop sensitive networks (long runs) because power pair wires have half the resistance of Micro cable

Mid Double-Ended Cordsets (Gray)



Double-ended cordsets are used for trunk or drop lines and make for a secure connection and simple timesaving installation. The connectors are keyed for error-free connection and are waterproof for continued operation even while submerged in the bilge.

- Rugged, IP68 rated connectors for continued connection integrity in marine environments
- Various cable lengths to match installation requirements
- Optimized for voltage drop sensitive networks (long runs) because power pair wires have half the resistance of Micro cable

Mid Double-Ended Cordsets (Blue)



Double-ended cordsets are used for trunk or drop lines and make for a secure connection and simple timesaving installation. The connectors are keyed for error-free connection and are waterproof for continued operation even while submerged in the bilge.

- Rugged, IP68 rated connectors for continued connection integrity in marine environments
- Various cable lengths to match installation requirements
- Optimized for voltage drop sensitive networks (long runs) because power pair wires have half the resistance of Micro cable

Copyright 2017 Maretron, LLP. All rights reserved. As Maretron is constantly improving its products, all specifications are subject to change without notice. Maretron's products are designed to be accurate and reliable; however, they should be used only as aids to navigation and vessel monitoring, and not as a replacement for traditional navigation and vessel monitoring techniques. A prudent captain or navigator never relies on a single source for navigation or system monitoring information. "NMEA 2000" is a registered trademark of the National Marine Electronics Association.

Mid Bulk Cable (Gray/Blue)

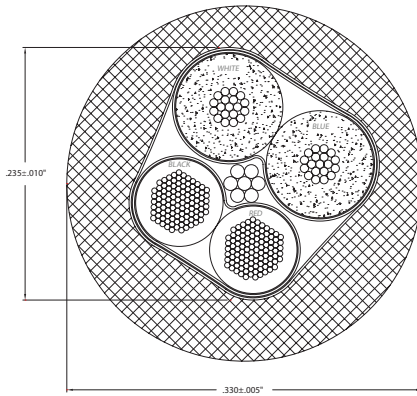

Specifications

OVERALL	
Outer Jacket Mat/Color:	PVC/Gray – DG1 PVC/Blue – DB1
Insulation Material:	PE (data wires), PVC (power wires)
Construction:	2x16 (1.29mm) AWG, 2x20 (0.81mm) AWG, 20 (0.81mm) AWG Drain Wire
Shielding (3 levels):	Foil (overall), Foil (power pair), Foil (data pair)
POWER PAIR	
Wire:	2x16 (1.29mm) AWG
Resistance/Conductor:	4.1 Ohms/1000 ft max
Max Amperage:	14 Amps
Color Code:	Red/Black
DATA PAIR	
Wire:	2x20 (0.81mm) (AWG)
Characteristic Impedance:	120 Ohms ± 10%
Capacitance:	10.75 pF/ft
Color Code:	White/Blue
APPROVALS	
UL:	PLTC 75°C Sunlight Resistant E90625, AWM 80°C 300V
CSA:	CMX-OUTDOOR-CMG LL54185 75°C, AWM I/II A/B 80C 300V FT4
NMEA:	NMEA 2000® Approved
IEC:	IEC-61162-3

Products

PART NUMBER	DESCRIPTION
DG1	Mid Bulk Cable (per meter – gray) (no spool)
DG1-100	Mid Bulk Cable (Two Pieces per 100m spool – gray)
DG1-100C	Mid Bulk Cable (Single Piece per 100m spool – gray)
DB1	Mid Bulk Cable (per meter – blue) (no spool)
DB1-100	Mid Bulk Cable (Two Pieces per 100m spool – blue)
DB1-100C	Mid Bulk Cable (Single Piece per 100m spool – blue)

Mid Double-Ended Cordsets (Gray)

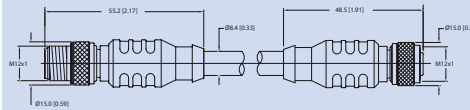

MALE END VIEW

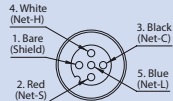

FEMALE END VIEW

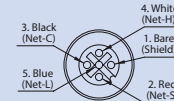

Specifications

MECHANICAL	
Contact Carrier Mat/Color:	Thermoplastic PUR/Blue-Gray
Molded Body Mat/Color:	Thermoplastic PUR/Blue-Gray
Contact Mat/Plating:	Brass/Gold
Coupling Nut Mat/Plating:	Brass/Nickel
Connector Outside Diameter:	0.59"
ELECTRICAL	
Current Rating:	4.0 Amps
Voltage Rating:	250 V
CABLE	
Outer Jacket Mat/Color:	PVC/Gray
Conductor Insulation Material:	PE (data pair), PVC (power pair)
Number of Conductors:	2x16 (1.29mm) AWG, Data 2x20 (0.81mm) AWG, 20 (0.81mm) AWG Drain Wire
Shielding (3 Levels):	Alum/Polyester Foil (Overall), Foil (Power Pair), Foil (Data Pair)
ENVIRONMENTAL	
Protection Class:	IEC IP68, NEMA 1,3,4,6P
Temperature Rating:	-40°C to 80°C to (-40°F to 176°F)
APPROVALS	
(Cable) UL:	PLTC 75°C Sunlight Resistant E90625, AWM 80°C 300V
(Cable) CSA:	CMX-OUTDOOR-CMG LL54185 75°C, AWM I/II A/B 80C 300V FT4
NMEA:	NMEA 2000® Approved
IEC:	IEC 61162-3

Products

PART NUMBER	DESCRIPTION
DM-DG1-DF-00.5	Mid Double-Ended Cordset - M to F - 0.5M (gray)
DM-DG1-DF-01.0	Mid Double-Ended Cordset - M to F - 1M (gray)
DM-DG1-DF-02.0	Mid Double-Ended Cordset - M to F - 2M (gray)
DM-DG1-DF-03.0	Mid Double-Ended Cordset - M to F - 3M (gray)
DM-DG1-DF-04.0	Mid Double-Ended Cordset - M to F - 4M (gray)
DM-DG1-DF-05.0	Mid Double-Ended Cordset - M to F - 5M (gray)
DM-DG1-DF-06.0	Mid Double-Ended Cordset - M to F - 6M (gray)
DM-DG1-DF-08.0	Mid Double-Ended Cordset - M to F - 8M (gray)
DM-DG1-DF-10.0	Mid Double-Ended Cordset - M to F - 10M (gray)

Mid Double-Ended Cordsets (Blue)

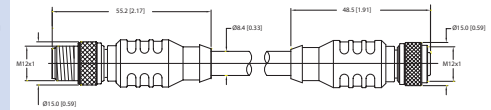

MALE END VIEW

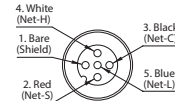

FEMALE END VIEW

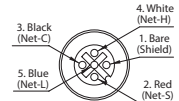

Specifications

MECHANICAL	
Contact Carrier Mat/Color:	Thermoplastic PUR/Blue-Gray
Molded Body Mat/Color:	Thermoplastic PUR/Blue-Gray
Contact Mat/Plating:	Brass/Gold
Coupling Nut Mat/Plating:	Brass/Nickel
Connector Outside Diameter:	0.59"
ELECTRICAL	
Current Rating:	4.0 Amps
Voltage Rating:	250 V
CABLE	
Outer Jacket Mat/Color:	PVC/Blue
Conductor Insulation Material:	PE (data pair), PVC (power pair)
Number of Conductors:	2x16 (1.29mm) AWG, 2x20 (0.81mm) AWG, 20 (0.81mm) AWG Drain Wire
Shielding (3 Levels):	Foil (Overall), Foil (Power Pair), Foil (Data Pair)
ENVIRONMENTAL	
Protection Class:	IEC IP68, NEMA 1,3,4,6P
Temperature Rating:	-40°C to 80°C to (-40°F to 176°F)
APPROVALS	
(Cable) UL:	PLTC 75°C Sunlight Resistant E90625, AWM 80°C 300V
(Cable) CSA:	CMX-OUTDOOR-CMG LL54185 75°C, AWM I/II A/B 80C 300V FT4
NMEA:	NMEA 2000® Approved
IEC:	IEC 61162-3

Products

PART NUMBER	DESCRIPTION
DM-DB1-DF-00.5	Mid Double-Ended Cordset - M to F - 0.5M (blue)
DM-DB1-DF-01.0	Mid Double-Ended Cordset - M to F - 1M (blue)
DM-DB1-DF-02.0	Mid Double-Ended Cordset - M to F - 2M (blue)
DM-DB1-DF-03.0	Mid Double-Ended Cordset - M to F - 3M (blue)
DM-DB1-DF-04.0	Mid Double-Ended Cordset - M to F - 4M (blue)
DM-DB1-DF-05.0	Mid Double-Ended Cordset - M to F - 5M (blue)
DM-DB1-DF-06.0	Mid Double-Ended Cordset - M to F - 6M (blue)
DM-DB1-DF-08.0	Mid Double-Ended Cordset - M to F - 8M (blue)
DM-DB1-DF-10.0	Mid Double-Ended Cordset - M to F - 10M (blue)

Nylon to Metal Connector Cable



Some products use inexpensive nylon connectors and when connected with metal connectors, the nylon threads can be damaged. This cable eliminates the problem by allowing nylon to nylon connections and metal to metal connections.

- NMEA 2000® Approved
- Waterproof rated to IP67

Micro 90° Male to Female Connector



A 90 degree male to female connector for Micro or Mid size cable runs or connections which is intended to aid turning tight radiuses without unduly straining the wires within a cable. Ideal when mounting a device in a location with shallow depth possibilities.

- NMEA 2000® Approved
- Waterproof rated to IP67

Mid Single-Ended Cordset Female to Open Pigtail (25 Meter Blue)



This 25 meter length Mid size cable with a Micro female connector on one end is intended for installation of devices such as Maretron's WSO100 Weather Station. The female connector should point towards the device and a field attachable male connector should be made onto the end connecting to the rest of the backbone.

- NMEA 2000® Approved
- Meets ABYC Power Pair size requirements
- Waterproof rated to IP67

Copyright 2017 Maretron, LLP. All rights reserved. As Maretron is constantly improving its products, all specifications are subject to change without notice. Maretron's products are designed to be accurate and reliable; however, they should be used only as aids to navigation and vessel monitoring, and not as a replacement for traditional navigation and vessel monitoring techniques. A prudent captain or navigator never relies on a single source for navigation or system monitoring information. "NMEA 2000" is a registered trademark of the National Marine Electronics Association.

Nylon to Metal Connector Cable

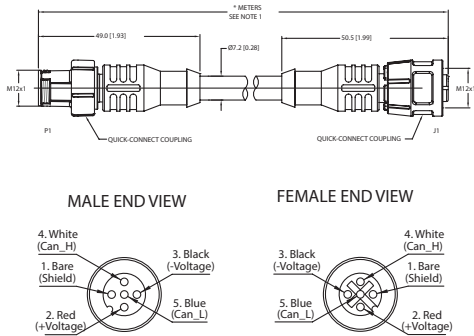

Specifications

MECHANICAL	
Molded Head Mat/Color:	Thermoplastic PUR/Blue-Gray
Contact Carrier Mat/Color:	Thermoplastic PUR/Black
Contact Mat/Plating:	Brass/Gold
Snap-Lock Mat/Color:	POM/Black
ELECTRICAL	
Rated Current:	4.0 Amps
Rated Voltage:	250 V
CABLE	
Outer Jacket Mat/Color:	PVC/Gray
Conductor Insulation Mat:	HDPE (Data), SRPVC (Power Pair)
Number of Conductors:	4X22 (0.65mm) AWG, 22 (0.65mm) AWG Drain Wire
Shielding (3-Levels):	Foil (Overall), Foil (Power Pair), Foil (Data Pair)
ENVIRONMENTAL	
Protection Class:	IEC IP67
Temperature Range:	-40°C to 80°C (-40°F to 176°F)
APPROVALS	
NMEA:	NMEA 2000® Approved
IEC:	IEC 61162-3

Products

PART NUMBER	DESCRIPTION
QCM-CG1-QCF-01	Nylon to Metal Connector Cable

Micro 90° Male to Female Connector

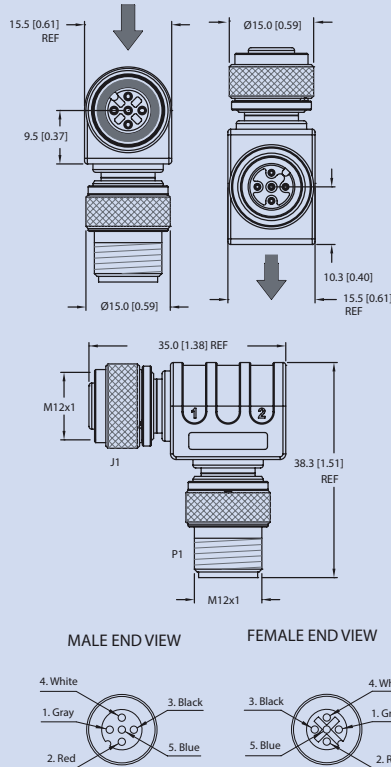

Specifications

MECHANICAL	
Molded Body Mat/Color:	Thermoplastic PUR/Gray
Contact Carrier Mat/Color:	Nylon PUR
Contact Mat/Plating:	Brass/Gold
Coupling Nut Mat/Plating:	Brass/Nickel
ELECTRICAL	
Rated Current:	4.0 Amps
Rated Voltage:	50 V
ENVIRONMENTAL	
Protection Class:	IEC IP67, NEMA 1,3,4,6P
Temperature Range:	-40°C to 105°C (-40°F to 221°F)
APPROVALS	
NMEA:	NMEA 2000® Approved
IEC:	IEC 61162-3

Products

PART NUMBER	DESCRIPTION
ELB-CM-CF	Micro 90° Male to Female Connector

Mid Single-Ended Cordset Female to Open Pigtail

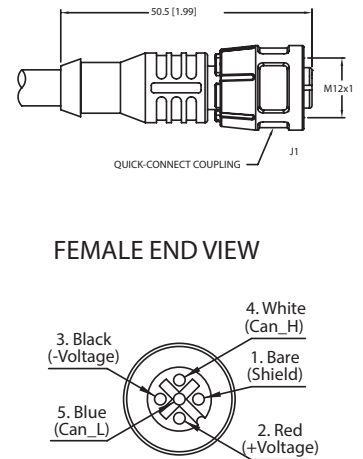

Specifications

MECHANICAL	
Molded Head Mat/Color:	Thermoplastic PUR/Black
Contact Carrier Mat/Color:	Thermoplastic PUR/Blue-Gray
Contact Mat/Plating:	Brass/Gold
Snap-Lock Mat/Color:	POM/Black
ELECTRICAL	
Rated Current:	4.0 Amps
Rated Voltage:	250 V
CABLE	
Outer Jacket Mat/Color:	PVC/Gray
Conductor Insulation Mat:	HDPE (Data), SRPVC (Power Pair)
Number of Conductors:	4X22 (0.65mm) AWG, 22 (0.65mm) AWG Drain Wire
Shielding (3-Levels):	Foil (Overall), Foil (Power Pair), Foil (Data Pair)
ENVIRONMENTAL	
Protection Class:	IEC IP67
Temperature Range:	-40°C to 80°C (-40°F to 176°F)
APPROVALS	
NMEA:	NMEA 2000® Approved
IEC:	IEC 61162-3

Products

PART NUMBER	DESCRIPTION
DF-DB1-25.0	Mid Single-Ended Cordset – Female to Open Pigtail – 25 Meter (blue)

Mini Bulk Cable (Gray/Blue)



Mini bulk cable is primarily used as trunk cable, but it can also be used as drop lines. Bulk cable with field-attachable connectors allows for maximum flexibility as cables can be made on the job to exact lengths.

- Meets and exceeds NMEA 2000® specifications for the highest reliability
- Trunk or drop cable for use with Mini connectors
- Used with field-attachable connectors to build exact length cables at the job site

Mini Field-Attachable Connector (Male/Female)



Field-attachable connectors allow you to make field connections to bulk cable. The color-coded screw terminals match the individual wire colors found within the bulk cables for error-free field installation.

- Color-coded screw terminators make for error-free field installation
- Rugged housing material designed to withstand harsh marine environments

Mini Double-Ended Cordset (Gray)



Double-ended cordsets are used for trunk or drop lines and make for a secure connection and simple timesaving installation. The connectors are keyed for error-free connection and are waterproof for continued operation even while submerged in the bilge.

- Rugged, IP68 rated connectors for continued connection integrity in marine environment
- Various cable lengths to match installation requirements

Copyright 2017 Maretron, LLP. All rights reserved. As Maretron is constantly improving its products, all specifications are subject to change without notice. Maretron's products are designed to be accurate and reliable; however, they should be used only as aids to navigation and vessel monitoring, and not as a replacement for traditional navigation and vessel monitoring techniques. A prudent captain or navigator never relies on a single source for navigation or system monitoring information. "NMEA 2000" is a registered trademark of the National Marine Electronics Association.

Mini Bulk Cable (Gray/Blue)

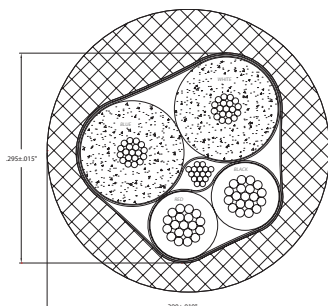

Specifications

OVERALL	
Outer Jacket Mat/Color:	PVC/Blue – NB1 PVC/Gray – NG1
Insulation Material:	PE (data), PVC (power)
Construction:	2x15 (1.45mm) AWG, 2x18 (1.02mm) AWG, 18 (1.02mm) AWG Drain Wire
Shielding (3 Levels):	Foil (overall), Foil (power pair), Foil (data pair)
POWER PAIR	
Wire:	2x15 (1.45mm) AWG
Resistance/Conductor:	3.44 Ohms/1000 ft max
Max Amperage:	16 Amps – NB1 14 Amps – NG1
Color Code:	Red/Black
DATA PAIR	
Wire:	2x18 (1.02mm) AWG
Characteristic Impedance:	120 Ohms ± 10%
Capacitance:	12 pF/1000 ft Max
Color Code:	White/Blue
APPROVALS	
UL:	PLTC 75°C Sunlight Resistant E90625, AWM 80°C 300V
CSA:	CMX-OUTDOOR-CMG LL54185 75°C, AWM I/II A/B 80C 300V FT4
NMEA:	NMEA 2000® APPROVED
IEC:	IEC-61162-3

Products

PART NUMBER	DESCRIPTION
NG1	Mini Bulk Cable (per meter – gray) (no spool)
NG1-100	Mini Bulk Cable (Two Pieces per 100m spool – gray)
NG1-100C	Mini Bulk Cable (Single Piece per 100m spool – gray)
NB1	Mini Bulk Cable (per meter – blue) (no spool)
NB1-100	Mini Bulk Cable (Two Pieces per 100m spool – blue)
NB1-100C	Mini Bulk Cable (Single Piece per 100m spool – blue)

Mini Field-Attachable Connector (Male/Female)

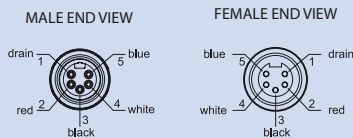
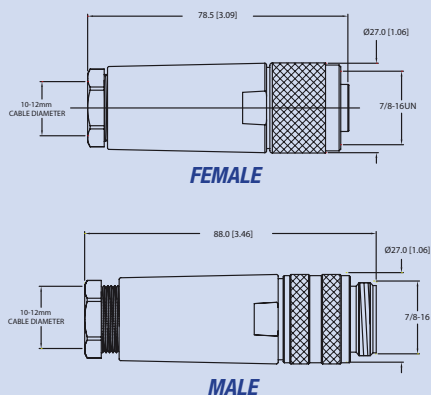

Specifications

MECHANICAL	
Housing Mat/Color:	Glass Filled Nylon/Black
Contact Mat/Plating:	Brass/Gold
Coupling Nut Material:	Anodized Aluminum
Maximum Wire Size:	16 (1.29mm) AWG
Termination Method:	Screw Terminal
ELECTRICAL	
Rated Current:	9.0 Amps
Rated Voltage:	250 Volts
ENVIRONMENTAL	
Protection Class:	IEC IP67
Temperature Range:	-40°C to 85°C (-40°F to 185°F)
APPROVALS	
NMEA:	NMEA 2000® Approved
IEC:	IEC-61162-3

Products

PART NUMBER	DESCRIPTION
FA-NF-ST	Mini Field Attachable Connector (Female)
FA-NM-ST	Mini Field Attachable Connector (Male)

Mini Double-Ended Cordset (Gray)

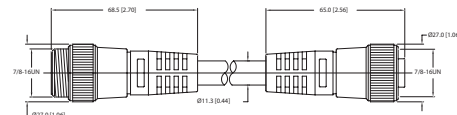

MALE END VIEW

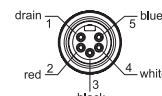

FEMALE END VIEW

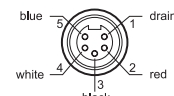

Specifications

MECHANICAL	
Contact Carrier Mat/Color:	Thermoplastic PUR/Blue-Gray
Molded Head Mat/Color:	Thermoplastic PUR/Blue-Gray
Contact Mat/Plating:	Brass/Gold
Coupling Nut Mat/Plating:	Brass/Nickel
Connector Outside Diameter:	1.06"
ELECTRICAL	
Current Rating:	9.0 Amps
Voltage Rating:	300 V
CABLE	
Outer Jacket Mat/Color:	PVC/Gray
Conductor Insulation Material:	PE (data pair), PVC (power pair)
Number of Conductors:	Power 2x15 (1.45mm) AWG, 2x18 (1.02mm) AWG, 18 (1.02mm) AWG Drain Wire
Shielding (3-Levels):	Braid (Overall), Foil (Power Pair), Foil (Data Pair)
ENVIRONMENTAL	
Protection Class:	IEC IP68, NEMA 1,3,4,6P
Temperature Rating:	-40°C to 80°C (-40°F to 176°F)
APPROVALS	
(Cable) UL:	PLTC 75°C Sunlight Resistant E90625, AWM 80°C 300V
(Cable) CSA:	CMX-OUTDOOR-CMG LL54185 75°C, AWM I/II A/B 80C 300V FT4
NMEA:	NMEA 2000® Approved
IEC:	IEC 61162-3

Products

PART NUMBER	DESCRIPTION
NM-NG1-NF-00.5	Mini Double-Ended Cordset - M to F - 0.5M (gray)
NM-NG1-NF-01.0	Mini Double-Ended Cordset - M to F - 1M (gray)
NM-NG1-NF-02.0	Mini Double-Ended Cordset - M to F - 2M (gray)
NM-NG1-NF-03.0	Mini Double-Ended Cordset - M to F - 3M (gray)
NM-NG1-NF-04.0	Mini Double-Ended Cordset - M to F - 4M (gray)
NM-NG1-NF-05.0	Mini Double-Ended Cordset - M to F - 5M (gray)
NM-NG1-NF-06.0	Mini Double-Ended Cordset - M to F - 6M (gray)
NM-NG1-NF-08.0	Mini Double-Ended Cordset - M to F - 8M (gray)
NM-NG1-NF-10.0	Mini Double-Ended Cordset - M to F - 10M (gray)

Mini Double-Ended Cordset (Blue)



Double-ended cordsets are used for trunk or drop lines and make for a secure connection and simple timesaving installation. The connectors are keyed for error-free connection and are waterproof for continued operation even while submerged in the bilge.

- Rugged, IP67 rated connectors for continued connection integrity in marine environment
- Various cable lengths to match installation requirements

Mini Tees



A Tee is used to tap into the trunk line for adding a drop connection. Two Mini Tees are available: 1) a Mini Tee with Mini connectors for the trunk and drop lines, and 2) a Mini/Micro Tee with Mini connectors for the trunk lines and a Micro connector for the drop line.

- Gold Contacts for greatest reliability
- Keyed connectors for error-free connections

Mini Powertap / Mini Power Cord



A Powertap is connected to a network backbone just like any Tee but rather than connecting a device, its purpose is to provide "bus" power. Typically a Powertap is placed as central as possible between total devices on backbone. Maretron Powertap uniquely provides two power inputs permitting doubled power provision for devices.

- Connects power supply to NMEA 2000® Trunk Line in convenient plug/play fashion
- Replaceable fuses to protect bus and connected components from excessive current

Copyright 2017 Maretron, LLP. All rights reserved. As Maretron is constantly improving its products, all specifications are subject to change without notice. Maretron's products are designed to be accurate and reliable; however, they should be used only as aids to navigation and vessel monitoring, and not as a replacement for traditional navigation and vessel monitoring techniques. A prudent captain or navigator never relies on a single source for navigation or system monitoring information. "NMEA 2000" is a registered trademark of the National Marine Electronics Association.

Mini Double-Ended Cordset (Blue)

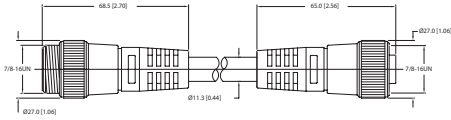

MALE END VIEW

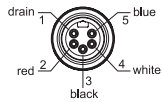

FEMALE END VIEW

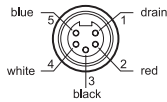

Specifications

MECHANICAL	<p>Contact Carrier Mat/Color: Thermoplastic PUR/Blue-Gray</p> <p>Molded Body Mat/Color: Thermoplastic PUR/Blue-Gray</p> <p>Contact Mat/Plating: Brass/Gold</p> <p>Coupling Nut Mat/Plating: Brass/Nickel</p> <p>Connector Outside Diameter: 1.06"</p>
ELECTRICAL	<p>Current Rating: 9.0 Amps</p> <p>Voltage Rating: 300 V</p>
CABLE	<p>Outer Jacket Mat/Color: PVC/Blue</p> <p>Conductor Insulation Material: PE (data pair), PVC (power pair)</p> <p>Number of Conductors: 2x15 (1.45mm) AWG, 2x18 (1.02mm) AWG, 18 (1.02mm) AWG Drain Wire</p> <p>Shielding (3-Levels): Braid (Overall), Foil (Power Pair), Foil (Data Pair)</p>
ENVIRONMENTAL	<p>Protection Class: IEC IP67, NEMA 1,3,4,6P</p> <p>Temperature Rating: -40°C to 80°C (-40°F to 176°F)</p>
APPROVALS	<p>(Cable) UL: PLTC 75°C Sunlight Resistant E90625, AWM 80°C 300V</p> <p>(Cable) CSA: CMX-OUTDOOR-CMG LL54185 75°C, AWM I/II A/B 80C 300V FT4</p> <p>NMEA: NMEA 2000[®] Approved</p> <p>IEC: IEC 61162-3</p>

Products

PART NUMBER	DESCRIPTION
NM-NB1-NF-00.5	Mini Double-Ended Cordset - M to F - 0.5M (blue)
NM-NB1-NF-01.0	Mini Double-Ended Cordset - M to F - 1M (blue)
NM-NB1-NF-02.0	Mini Double-Ended Cordset - M to F - 2M (blue)
NM-NB1-NF-03.0	Mini Double-Ended Cordset - M to F - 3M (blue)
NM-NB1-NF-04.0	Mini Double-Ended Cordset - M to F - 4M (blue)
NM-NB1-NF-05.0	Mini Double-Ended Cordset - M to F - 5M (blue)
NM-NB1-NF-06.0	Mini Double-Ended Cordset - M to F - 6M (blue)
NM-NB1-NF-08.0	Mini Double-Ended Cordset - M to F - 8M (blue)
NM-NB1-NF-10.0	Mini Double-Ended Cordset - M to F - 10M (blue)

Mini Tees

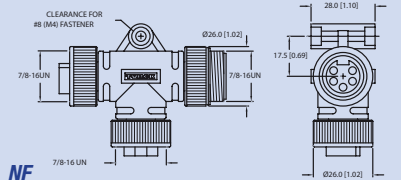

NF

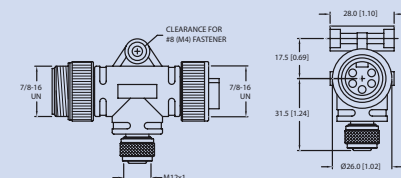
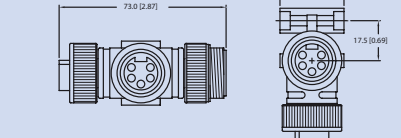

CF

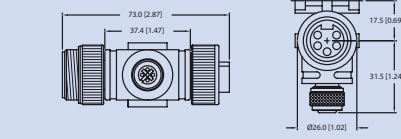

Specifications

MECHANICAL	<p>Molded Body Mat/Color: Thermoplastic PUR/Blue-Gray</p> <p>Contact Carrier Mat/Color: Thermoplastic PUR/Blue-Gray</p> <p>Contact Mat/Plating: Brass/Gold</p> <p>Coupling Nut Mat/Plating: Brass/Nickel</p>
ELECTRICAL	<p>Rated Current: 9.0 Amps – NM-NF-NF 4.0 Amps (Micro) 9.0 Amps (Mini) – NM-CF-NF</p> <p>Rated Voltage: 600 V – NM-NF-NF 250 V – NM-CF-NF</p>
ENVIRONMENTAL	<p>Protection Class: IEC IP67, NEMA 1,3,4,6P</p> <p>Temperature Range: -40°C to 80°C (-40°F to 176°F)</p>
APPROVALS	<p>NMEA: NMEA 2000[®] APPROVED</p> <p>IEC: IEC 61162-3</p>

Products

PART NUMBER	DESCRIPTION
NM-NF-NF	Mini Tee
NM-CF-NF	Mini/Micro Tee

Mini Powertap / Mini Power Cord

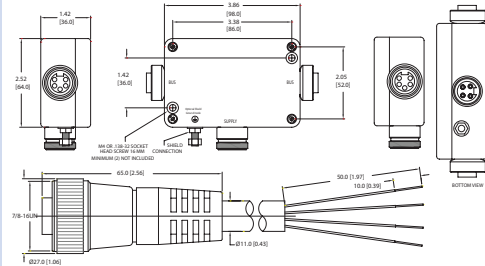

Color	Name	Usage	Connector
Black	NET-C	Ground	V-1 & V-2
White	NET-S	Power	V+1 & V+2
Green	NET-C	Ground	V-1 & V-2
Red	NET-S	Power	V+1 & V+2

Specifications

ELECTRICAL	<p>Protection Circuit: Slo-Blow Fuse: 8 Amps, 250 V Metric Fuse Block: 5x20 mm Trip Time: 4 sec Min to 100 sec max Type: MBR 3045PT Max: Reverse Voltage VRWM=45 V Max: Average Fwd Cur IFRM=30 Amps Peak Surge Cur I=8.3 sec., IFSM=200 Amps Max Vf = 0.65 V @ 125°C and If=20 Amps</p> <p>Bus Line Minimum Conductor: 16 AWG 8 Amps (Mini 5-Pin)</p> <p>Supply Line Minimum Conductor: 16 AWG 8 Amps (Mini 4-Pin)</p>	NF-NM4P-NF
ENVIRONMENTAL	<p>Temperature Range: -40°C to 70°C (-40°F to 158°F)</p> <p>Storage Temperature: -40°C to 85°C (-40°F to 185°F)</p>	
APPROVALS	<p>NMEA: NMEA 2000[®] APPROVED</p> <p>IEC: IEC 61162-3</p>	
MECHANICAL	<p>Molded Body Mat/Color: Thermoplastic PUR/Yellow</p> <p>Outer Jacket Mat/Color: PVC/Yellow</p> <p>Contact Carrier Mat/Color: Thermoplastic PUR/Yellow</p> <p>Contact Mat/Plating: Brass/Gold</p> <p>Coupling Nut Mat/Plating: Brass/Nickel</p> <p>Conductor Insulation Mat: PVC</p>	NM4P-01, NM4P-05
ELECTRICAL	<p>Conductors: 4x16 (1.29mm) AWG</p> <p>Current Rating: 9.0 Amps</p> <p>Voltage Rating: 600 V</p>	
ENVIRONMENTAL	<p>Protection Class: IEC IP67, NEMA 1,3,4,6P</p> <p>Temperature Range: -40°C to 105°C (-40°F to 221°F)</p>	
APPROVALS	<p>NMEA: NMEA 2000[®] APPROVED</p> <p>IEC: IEC 61162-3</p>	

Products

PART NUMBER	DESCRIPTION
NF-NM4P-NF	Mini Powertap - Female-Female with Fuses
NM4P-01	Mini Power Cord - Female to Pigtail - 1 Meter
NM4P-05	Mini Power Cord - Female to Pigtail - 5 Meter

Mini Termination Resistor (Male/Female)



Termination Resistors are required on a NMEA 2000® network and are placed at each end of a network trunk cable. Like the double-ended cordsets, the termination resistors are waterproof and continue to function even while submerged in the bilge.

- Diagnostic versions indicate correct polarity at a glance to ensure power connections have been made properly
- Screw connector for positive connection
- Termination resistors are used to terminate both ends of the trunk line

Mini 90° Male to Female Connector



The Mini Elbow is used in spots where it is impossible to bend a cordset around tight corners. The elbow easily connects to a tee or double-ended cordsets making 90 [degree] turns practical at the end or anywhere along the line.

- Mounting hole for secure fastening of cabling system
- Waterproof seals for reliable connections
- Nickel plated brass ideally suited for harsh marine environment

Mini Male to Micro Female Reducer



The reducer is used to change from a Mini cable to Micro or Mid cable. For example, one end of the network might be terminated at the top of the mast but it may not be desirable to run a Mini trunk cable up the mast. In this case, you can switch over to Micro or Mid cable at the base of the mast using the reducer and continue up the mast with Micro or Mid cable.

- Corrosion resistant Nickel plated Brass
- Weatherproof to IP67
- Reduces Mini Backbone to Micro/Mid Cable

Copyright 2017 Maretron, LLP. All rights reserved. As Maretron is constantly improving its products, all specifications are subject to change without notice. Maretron's products are designed to be accurate and reliable; however, they should be used only as aids to navigation and vessel monitoring, and not as a replacement for traditional navigation and vessel monitoring techniques. A prudent captain or navigator never relies on a single source for navigation or system monitoring information. "NMEA 2000" is a registered trademark of the National Marine Electronics Association.

Mini Termination Resistor (Male/Female)

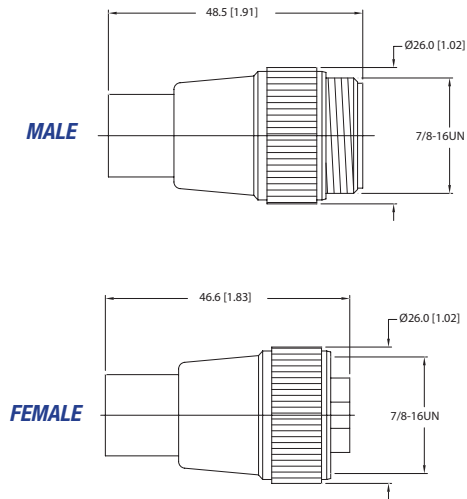

Specifications

MECHANICAL Molded Body Mat/Color:	Thermoplastic PUR/Blue-Gray – TR-NM, TR-NF
Contact Carrier Mat/Color:	Thermoplastic PUR/Clear –
Contact Mat/Plating:	TRL-NM, TRL-NF
Coupling Nut Mat/Plating:	Thermoplastic PUR/Blue-Gray Brass/Gold Brass/Nickel
ELECTRICAL Rated Voltage:	300 V DC
Internal Resistor:	120 Ohms (1/2 W)
Voltage Monitoring: (Bus Power)	Green: Correct Polarity Red: Reversed Polarity – TRL-NM, TRL-NF
ENVIRONMENTAL Protection Class:	IEC IP67, NEMA 1,3,4,6, 13
Temperature Rating:	-40°C to 80°C (-40°F to 176°F)
APPROVALS NMEA:	NMEA 2000® Approved
IEC:	IEC 61162-3

Products

PART NUMBER	DESCRIPTION
TR-NM	Mini Termination Resistor (Male)
TR-NF	Mini Termination Resistor (Female)
TRL-NM	Mini Termination Resistor with LED (Male)
TRL-NF	Mini Termination Resistor with LED (Female)

Mini 90° Male to Female Connector

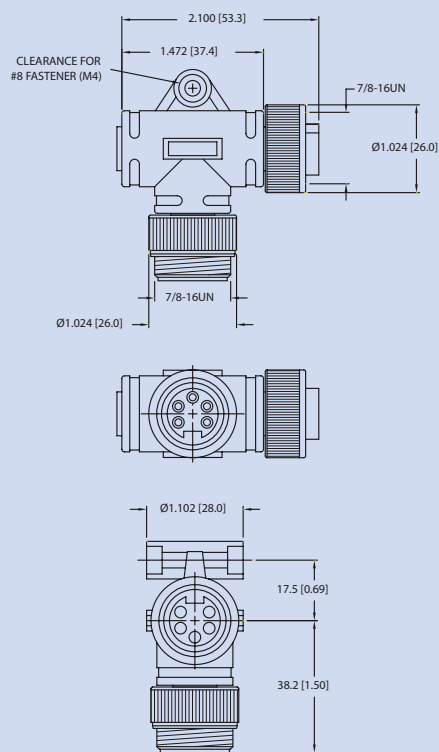

Specifications

MECHANICAL Molded Body Mat/Color:	Thermoplastic PUR/Blue
Contact Carrier Mat/Color:	Thermoplastic PUR/Blue
Contact Mat/Plating:	Brass/Gold
Coupling Nut Mat/Plating:	Brass/Nickel
ELECTRICAL Rated Current:	9.0 Amps
Rated Voltage:	600 V
ENVIRONMENTAL Protection Class:	IEC IP67, NEMA 1,3,4,6 P
Temperature Range:	-40°C TO 80°C (-40°F to 176°F)
APPROVALS NMEA:	NMEA 2000® Approved
IEC:	IEC 61162-3

Products

PART NUMBER	DESCRIPTION
ELB-NM-NF	Mini 90° Male to Female Connector

Mini Male to Micro Female Reducer

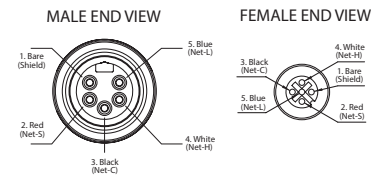
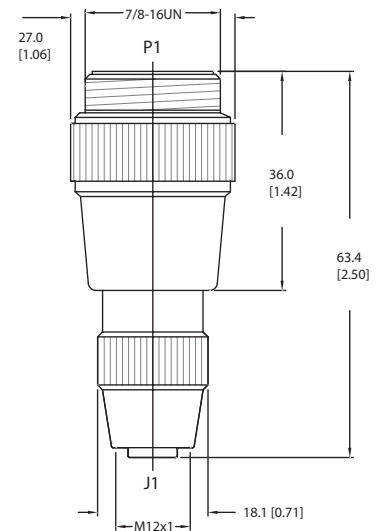

Specifications

MECHANICAL Contact Mat/Plating:	Brass/Gold
Coupling Nut Mat/Plating:	Brass/Nickel
ELECTRICAL Rated Current:	4.0 Amps
Rated Voltage:	250 V
ENVIRONMENTAL Protection Class:	IEC IP67, NEMA 1,3,4
Temperature Range:	-40°C TO 75°C (-40°F to 167°F)
APPROVALS NMEA:	NMEA 2000® APPROVED
IEC:	IEC 61162-3

Products

PART NUMBER	DESCRIPTION
NM-CF	Mini Male to Micro Female Reducer

Mini Gender Changers



Maretron cables have a male connector on one end and a female connector on the other end. Normally, the male connector points back towards the network power supply, but on some occasions, this gets reversed and a gender changer can be used to get back to the desired connector type.

- Waterproof seals for reliable connections
- Easily swap connector gender to get back to desired connector type

Mini Bulkhead Feed-Thru



The Bulkhead Feed-Thru allows ease of installation through panels or bulkheads and establishes future connection points in a network installation. The bulkhead feed-thru also maintains the integrity of watertight bulkheads by providing a waterproof seal and connection.

- Features rugged keyways for positive alignment of connections
- Waterproof rated to IP67

N2KMeter®



The N2KMeter® enables trained and untrained personnel to diagnose and trouble-shoot network installations quickly and easily. Completely passive on the network, the meter analyzes both data and power lines on the network. In seconds, both network-wide and device-specific traffic as well as power monitoring information is captured and displayed on a simple user interface.

- Diagnostic tool for NMEA 2000® networks
- Evaluates physical layer device functions on a network
- Data at boat can be locked in and then evaluated later on bench

Copyright 2017 Maretron, LLP. All rights reserved. As Maretron is constantly improving its products, all specifications are subject to change without notice. Maretron's products are designed to be accurate and reliable; however, they should be used only as aids to navigation and vessel monitoring, and not as a replacement for traditional navigation and vessel monitoring techniques. A prudent captain or navigator never relies on a single source for navigation or system monitoring information. "NMEA 2000" is a registered trademark of the National Marine Electronics Association.

Mini Gender Changers

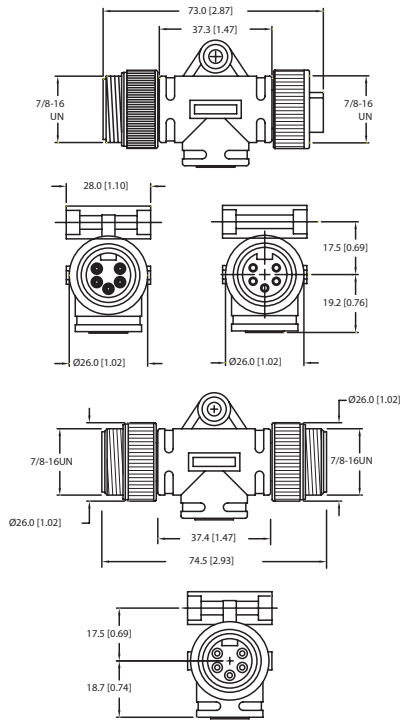

Specifications

MECHANICAL	Molded Body Mat/Color: Thermoplastic PUR/Blue-Gray Contact Carrier Mat/Color: Thermoplastic PUR/Blue-Gray Contact Mat/Plating: Brass/Gold Coupling Nut Mat/Plating: Brass/Nickel
ELECTRICAL	Rated Current: 9.0 Amps Rated Voltage: 600 V
ENVIRONMENTAL	Protection Class: IEC IP67, NEMA 1,3,4,6P – NM-NM IEC IP67, NEMA 1,3,4,13 – NF-NF Temperature Range: -40°C to 70°C (-40°F to 158°F) – NM-NM -40°C to 55°C (-40°F to 131°F) – NF-NF
APPROVALS	NMEA: NMEA 2000® Approved IEC: IEC 61162-3

Products

PART NUMBER	DESCRIPTION
NM-NM	Mini Gender Changer (Male/Male)
NF-NF	Mini Gender Changer (Female/Female)

Mini Bulkhead Feed-Thru

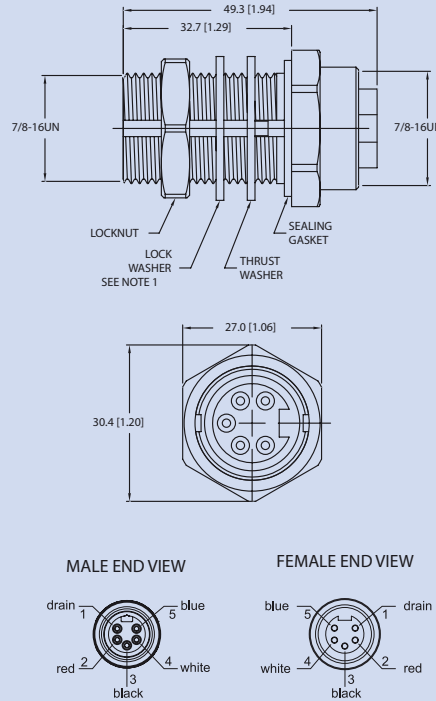

Specifications

MECHANICAL	Contact Carrier Mat/Color: Thermoplastic PUR/Blue-Gray Housing Mat/Plating: Brass/Nickel Contact Mat/Plating: Brass/Gold Gasket Material: Nitrile (Buna N) Accommodates Wall (thick): .040" (1.0 mm) to .875" (22.2 mm)
ELECTRICAL	Voltage Rating: 600 V Max Amperage: 9.0 Amps 5x22 AWG (0.65mm)
ENVIRONMENTAL	Protection Class: IEC IP67 Temperature Range: -40°C to 105°C (-40°F to 221°F)
APPROVALS	NMEA: NMEA 2000® Approved IEC: IEC 61162-3

Products

PART NUMBER	DESCRIPTION
BHF-NM-NF	Mini Bulkhead Feed-Thru

N2KMeter®

Electrician Mode (Simple)

1. Plug in and set N2KMeter® rotary switch to "autosearch"

2. Identify network health
- Happy face = healthy 😊
 - Neutral face = nominal 😐
 - Sad face = faulty ☹️

3. Scroll through faults. Refer to user manual to link these faults to most likely network problems or freeze and lock settings for review back at the shop by an NMEA 2000® expert.



Expert Mode (Advanced)

1. Scroll through NMEA 2000® parameters for each active NMEA 2000® node (MAC ID)

- Communication errors (rate, cumulative #)
- Bandwidth (% of full usage)
- Power supply and shield voltages
- Data bit quality (dominant, recessive, +, -, differential voltage, CMV)

2. Check values (both numeric and icons)

- Happy face = within spec 😊
- Neutral face = very close to limit 😐
- Sad face = out of limit ☹️

3. Refer to user manual to link these faults to most likely network problems

Specifications

MECHANICAL	Power Supply: Network 7 - 30v DC < 90MA Batteries 2 X AA Alkaline Batteries 6 Hours Of Operation Approx. 1 Year Data Retention
Connectors: Micro Connector	Band Rates: 125k, 250k and 500k (Auto-detect)
Analogue Accuracy: Bus Power ±100mV, Bus Signal ±20mV	Analogue Range: Bus Power 0 to 25v with over/under Range Indication Bus signal -5 To 10v with over/under range Indication
Analogue Sample Rate: Bus Power 1 Khz Bus Signal Ideal Sample Pt±250ns	Signal Error Threshold: NMEA 2000® Spec for Network Power
Bus Load Measurement: Bus Message Rate Measurement:	Detects Bus Idle In Real Time
Error Rate Measurement:	Detects 100% of Individual CAN Frames in Real Time Detects 100% of Individual Error Frames in Real Time
APPROVALS	NMEA: NMEA 2000® Approved

Products

PART NUMBER	DESCRIPTION
N2KMETER-01	Diagnostic Meter w/1m Micro Cordset

Maretron NMEA 2000® Network Installation Guide

Installing an NMEA 2000® Network

Installing an NMEA 2000® network consists of interconnecting NMEA 2000® electronic devices using plug-and-play cables and connectors. The following pages provide a brief description of how to set up a NMEA 2000® network using five basic steps:

1. Cable and Connector Network Basics
2. Installing Terminators
3. Supplying Power
4. Grounding the Network
5. Checking the Network

Please note that this installation guide contains a brief description of the basic concepts of installing an NMEA 2000® network and Maretron suggests that you consult a trained professional for any installation. You can learn more about installing NMEA 2000® networks by contacting the National Marine Electronics Association (NMEA) at www.nmea.org and consulting the following documents:

- NMEA 2000® Standard for Serial-Data Networking of Marine Electronic Devices
- NMEA Installation Standards

1. Cable and Connector Network Basics

1.1 Network Topology

The NMEA 2000® cable system uses a trunk (sometimes referred to as the backbone) and drop line topology as shown in Figure 1.

The NMEA 2000® cable system includes five wires within a single waterproof cable: two signal wires, power and ground wires, and a drain wire. The drain wire shields the signal, power, and ground wires from external Radio Frequency Interference (RFI) and helps reduce RFI emission from the cable.

You can connect devices using one of three cable options:

Mini - This is commonly used for the trunk line on the network because of its greater current carrying capacity (8 amps) as

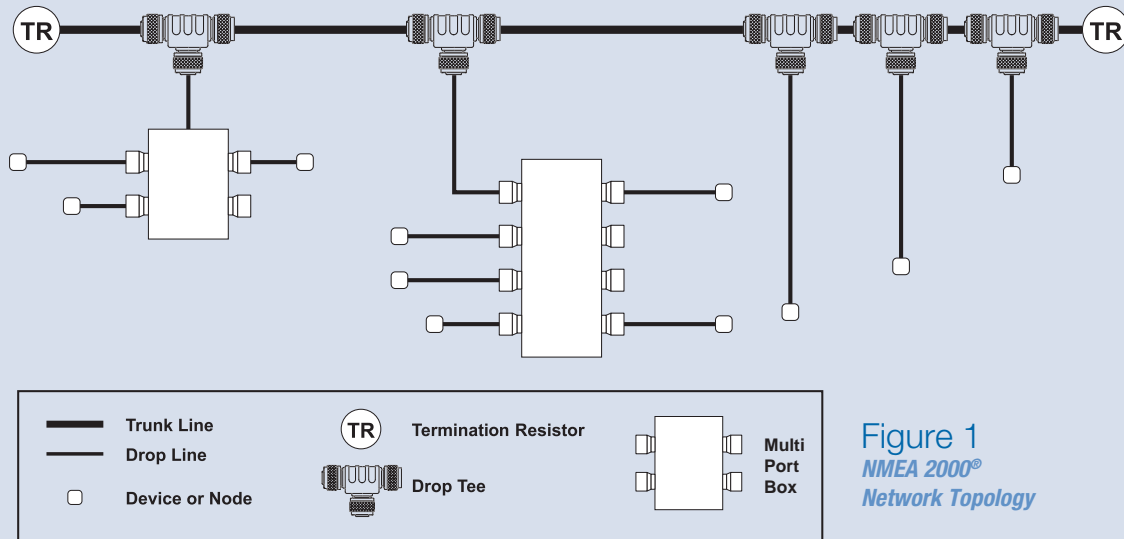
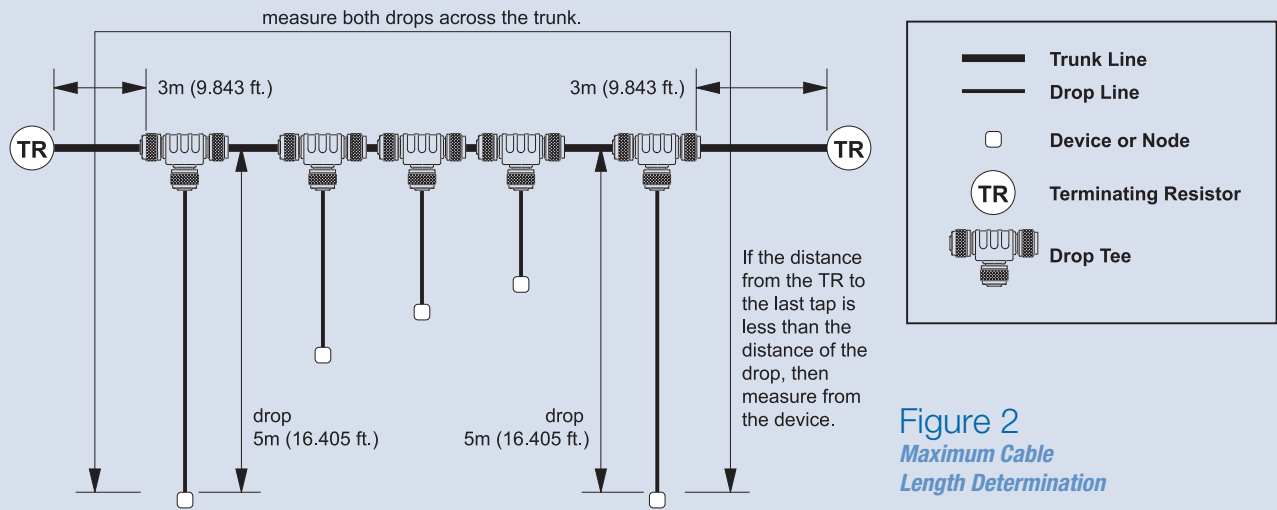

Figure 1
NMEA 2000®
Network Topology



opposed to Micro cable (4 amps). Mini cable has an outside diameter in the range from 0.41 to 0.49 inches. Its maximum installed bend radius is 7x the cable diameter. You can also use this type of cable for drop lines.

Mid - This is commonly used for smaller networks as either the network trunk line or as drop lines. Mid cable and connectors are rated to 4 amps just like the Micro cable, however the larger diameter power conductors within the Mid cable provides for less voltage drop over Micro cable, especially for long runs. The diameter of the Mid cable is 0.33 inches.

Micro - This cable type is typically used as the drop line connecting devices to the main trunk line with an outside diameter in the range from 0.24 to 0.28 inches. Micro cable has a smaller diameter and is more flexible than mini cable with an installation bend radius of 7x the cable diameter. Smaller networks use this type of cable for both the trunk and drop lines.

You construct the trunk line using double-ended cordsets connected between tees or taps. One end of the cordset has a male connector with male pins while the other end of the cordset has a female connector and female receptacles. The connectors are keyed so they can only connect to each other in one way. As an alternative to double-ended

cordsets, you can make your own trunk line using bulk cable and field-attachable connectors. If you decide to add equipment later, you can simply disconnect a cordset from a tee, add another tee directly to the existing tee, re-connect the cordset and add the new component to the system using a drop cable. Alternatively, you could cut the trunk line, add two field-attachable connectors and insert a new tee. Trunk lines can also be run up to watertight bulkheads and connected to a waterproof bulkhead feed-thru connector to maintain the integrity of watertight compartments.

To drop off the trunk line, you connect a device using a tee connector. Daisy-chaining of devices is not allowed, as it is a requirement to be able to remove a component from the network without affecting any other device. This allows you to remove a device for servicing while the rest of the network remains operational. Multiport boxes are also available where instruments tend to be clustered, around the helm for example.

1.2 Maximum Cable Distance

The cable distance between any two points (a point being an electronic product or terminator) must not exceed 250 meters (820 feet) for a system based on the Mini or Mid trunk cable or 100 meters (328 feet) for a system based on a Micro trunk cable.

For most cases, the maximum distance should be measured between termination resistors. However, if the distance from a trunk line tee to the farthest device connected to the trunk line is greater than the distance from the tee to the nearest terminating resistor (TR), then you MUST include the drop line length as part of the cable length in your maximum cable distance calculation. Figure 2 shows an example where both 5 meter drops must be included in the maximum cable distance since the drops are longer than the distance from the tee to termination resistor.

1.3 Cumulative Drop Line Length

The cumulative drop line length refers to the sum of all drop lines, Mini, Mid or Micro cable in the cabling system. This sum cannot exceed 78 meters (256 feet). Figure 3 shows an example using four drop tees and two multiport drops to attach 11 devices to the trunk line. The cumulative drop line length is 37 meters (122 feet) and no single device is more than 6 meters (20 feet) from the trunk line.

1.4 Maximum Drop Line Length

The maximum cable distance from any device on a branching

drop line to the trunk line is 6 meters (20 feet).

1.5 Maximum Number of Devices

A maximum of 50 physical devices shall be connected to the network, and the disconnection of any device shall not interrupt any other device on the network.

1.6 NMEA 2000® Cable

The Mini, Mid and Micro cables contain five wires: One twisted pair (red and black) for 12VDC power, one twisted pair (blue and white) for signal and a drain wire (bare).

The following table shows the color, name, and usage for each wire contained within the cable.

Color	Name	Usage
White	NET-H	Signal
Blue	NET-L	Signal
Bare	SHIELD	Drain
Black	NET-C	Ground
Red	NET-S	Power

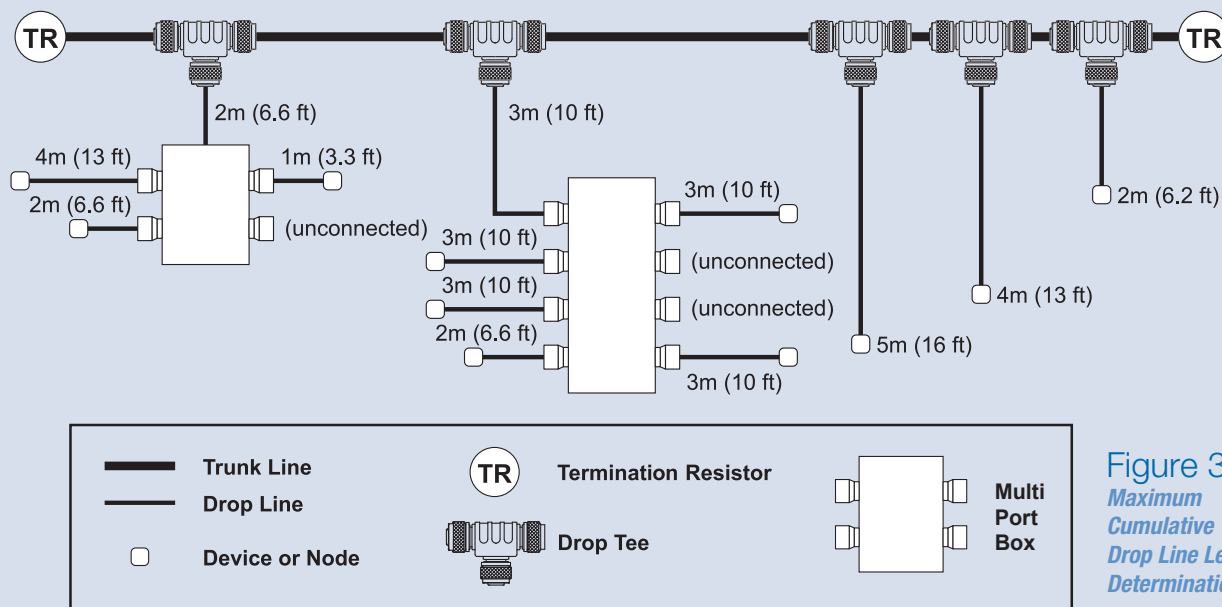

Figure 3
Maximum
Cumulative
Drop Line Length
Determination

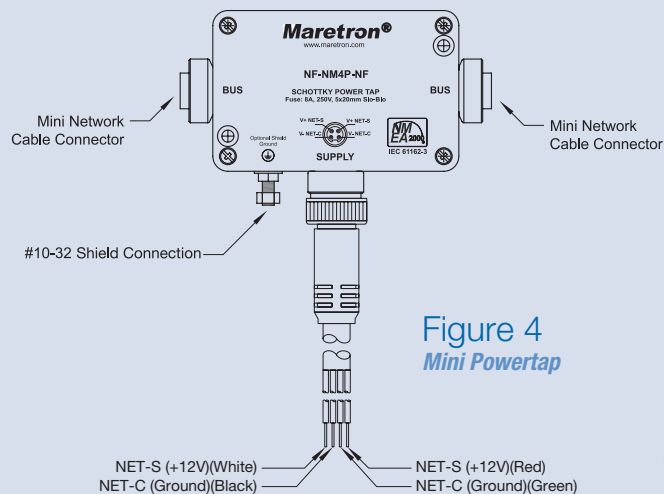

Figure 4
Mini Powertap

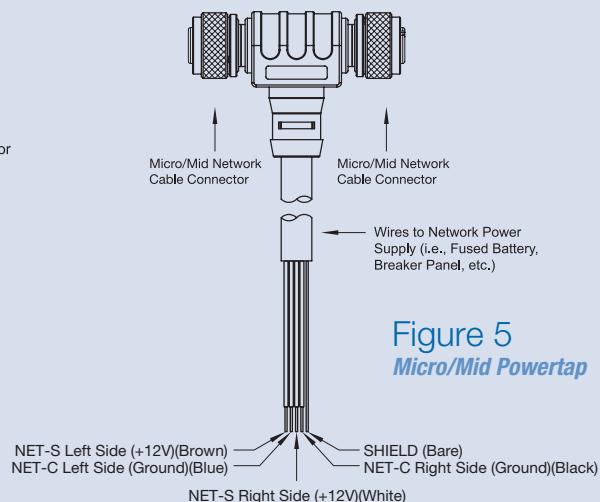
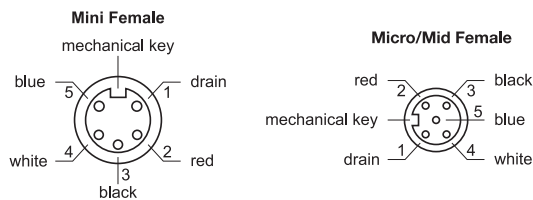

Figure 5
Micro/Mid Powertap

1.7 NMEA 2000® Connectors

Connectors attach cables to devices or other components of the NMEA 2000® cable system. This allows the network to be completely “plug-and-play”. Connections can be made with pre-molded cordsets or with field-attachable connectors. The following diagram shows the pins found within Mini connector and the Micro and Mid connector and the corresponding wire colors for those pins.



2. Installing Terminators

Termination resistors are attached to each end of the trunk cable to reduce reflections of the communication signals on the network. If you do not use termination resistors as described, the network will not operate properly. Termination resistors are typically connected directly to the last tee on the trunk line although they can be connected to a cordset extending from the last tee on a trunk line. Inline terminators are also available and they are used to terminate the network at the last product.

3. Supplying Power

NMEA 2000® networks can use a power supply originating from a single-point connection to the vessel’s 12 volt battery or one or more isolated power supplies distributed along the network, but not a combination of battery and power supply connections. For the purpose of this installation guide, we will focus on the power source being a single-point connection to the vessel’s battery. Over current protection should be provided and should be sized in accordance with ABYC E-11, AC and DC ELECTRICAL SYSTEMS ON BOATS, taking into consideration the smallest gauge of cable being used for the backbone or drop cables. The NET-S wire is connected to the positive side of the battery while NET-C is connected to the negative side of the battery.

3.1 Mini Power Connection

Power is supplied to a Mini trunk line via a Powertap that is shown in Figure 4. Note that the Mini power cable does not have a shield wire as this connection is made to the screw terminal on the Powertap itself.

3.2 Mini Power Capability

Although Mini cable is rated to 8 amps, the cable system can support a total load of more than 8 amps. For example, 16 amps of power could be supplied to the middle of the trunk where 8 amps is supplied to both sides of the power tap. The

Powertap can handle large loads as long as no more than 8 amps is drawn through any single segment of the trunk line. However, cable resistance may limit your application to less than 8 amps.

3.3 Micro/Mid Power Connection

Like the Mini power connection, power is supplied to a Micro/Mid trunk line via a Powertap, which is shown in Figure 5.

3.4 Micro/Mid Power Capability

Micro/Mid cable is rated to 4 amps but like Mini cable, strategic placement of the power source could support higher current. For example, 8 amps of power could be supplied to the middle of the trunk where 4 amps is supplied to both sides of the power tap. It can handle large loads as long as no more than 4 amps is drawn through any single segment of the trunk line. However, cable resistance may limit your application to less than 4 amps

3.5 End-Powered Network

End-powered networks are typically seen on smaller vessels with only a few NMEA 2000® devices. Figure 6 shows an end-powered network.

3.6 Middle-Powered Network

A middle-powered network is typically found on larger vessels and is any network where the power is connected to the network at some location other than at the end. This

network consists of two legs, one leg extending in each direction from the power insertion point. Figure 7 shows a middle-powered network.

3.7 Maximum Power Supply Voltage Drop

The NMEA 2000® network is designed to work properly as long as there is no more than a 1.5 volt difference in the power supply voltage between any two devices on the network. Therefore, you should perform an estimate of the voltage drop across a network using the following equation:

$$\text{Voltage Drop} = 0.1 \times \text{Network Loads} \times \text{Network Length} \times \text{Cable Resistance}/100$$

Where: Network Loads is sum of Load Equivalent Numbers (LEN) for all devices (see device nameplate)
 Network Length is in meters
 Cable resistance is in ohms/100 meters

Power supply voltage drop estimates resulting in less than 1.5 volts across the entire network require no further analysis. Likewise, estimates ranging between 1.5 and 3.0 volts require no further analysis as long as a mid-powered network is used. Occasionally, estimated power supply voltage drops will occur outside these limits and will require further consideration through detailed calculations by certified technicians.

4. Ground the Network

The NMEA 2000® network should be grounded at ONE

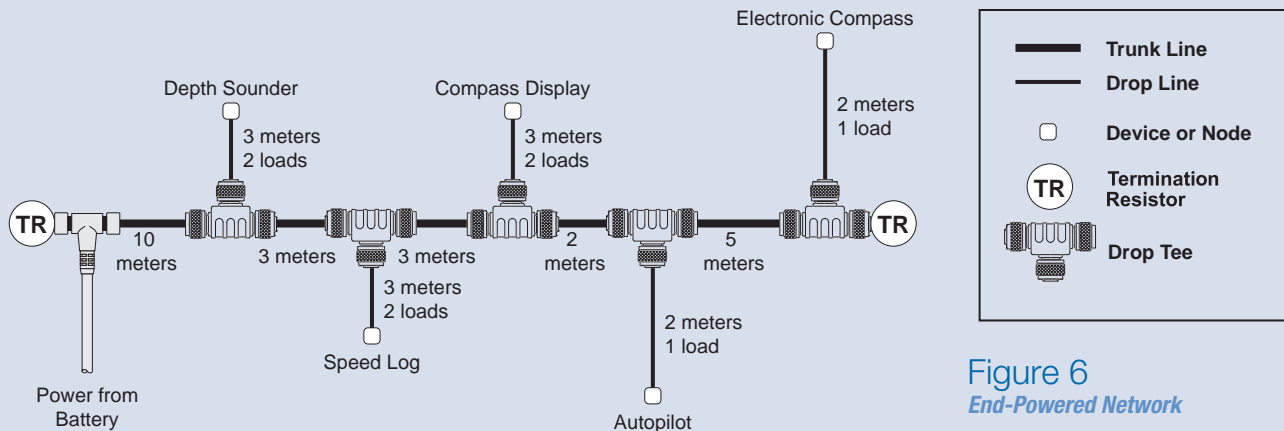

Figure 6
End-Powered Network

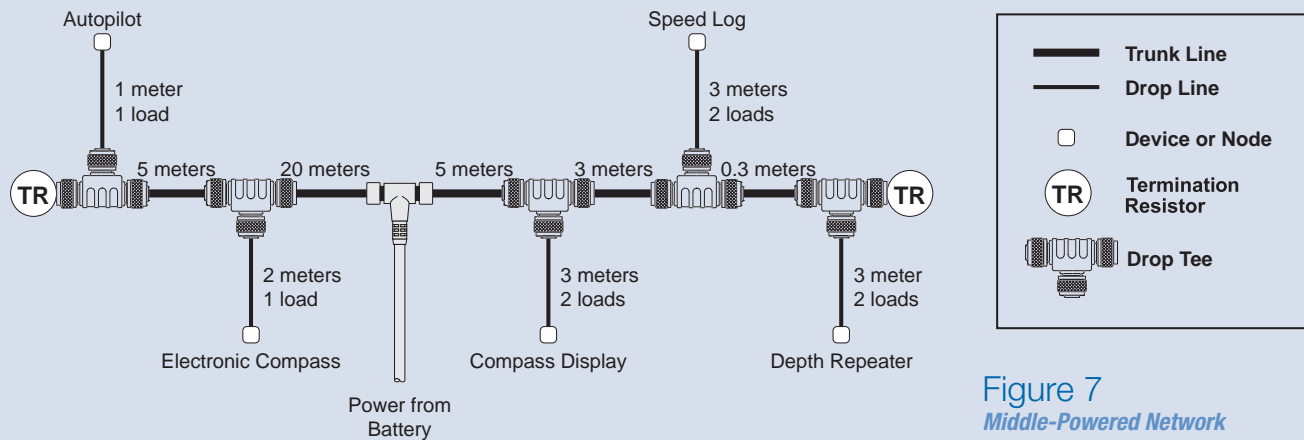

Figure 7
Middle-Powered Network

location. Grounding at more than one location may produce ground loops, which can cause problems with communications on the network. In addition to the ground wire, connect the drain or SHIELD wire at the supply ground location and NO other place.

5. Checking Your Network

Verify that the network has been correctly designed and installed by reviewing the following checklist:

- Number of devices does not exceed 50
- Maximum Mini cable distance between any two devices does not exceed 250 meters (820 feet)
- Maximum Micro/Mid cable distance between any two devices does not exceed 100 meters (328 feet)
- Maximum cumulative drop line length does not exceed 78 meters (256 feet)
- No drop should be greater than 6 meters (20 feet)
- Termination resistors are installed on both ends of the trunk
- The network is grounded at a single location
- The SHIELD wire is connected to a single point, the supply ground

If you are having difficulties with the network make sure to check the following most common network problems:

- More or less than two terminating resistors
- Loose connections, make sure that all connectors are securely fastened
- Excessive trunk line length—especially with Micro cable
- Excessive drop line cable length
- Improper shield and ground connection at the power supply
- Shorts and opens in field-attachable connectors
- Failure to perform power distribution calculations for new installations and when adding new devices
- Using a typical device current rather than maximum current for power distribution calculations

In order to insure the proper installation and configuration of an NMEA 2000® network, it is a good idea to have available at least one N2KMeter®. The N2KMeter® greatly simplifies network diagnostics and can detect many fault conditions including:

- Opens and shorts
- Incorrect topology
- Bad nodes
- Bad termination
- Improper shield connection
- Intermittent problems
- Excessive scan rate
- Common mode voltage

N2KBuilder®

NMEA 2000® Network Design Software

N2KBuilder® software is a powerful, free PC-based tool for designing and verifying the integrity of NMEA 2000® networks. The N2KBuilder® software, when installed on a Windows PC and used as part of an integrated design workflow can be used to plan, document, and validate the design of complex NMEA 2000® networks. In addition, N2KBuilder® will directly produce a Bill of Materials (BOM) for Maretron products, eliminating guesswork and transcription errors.

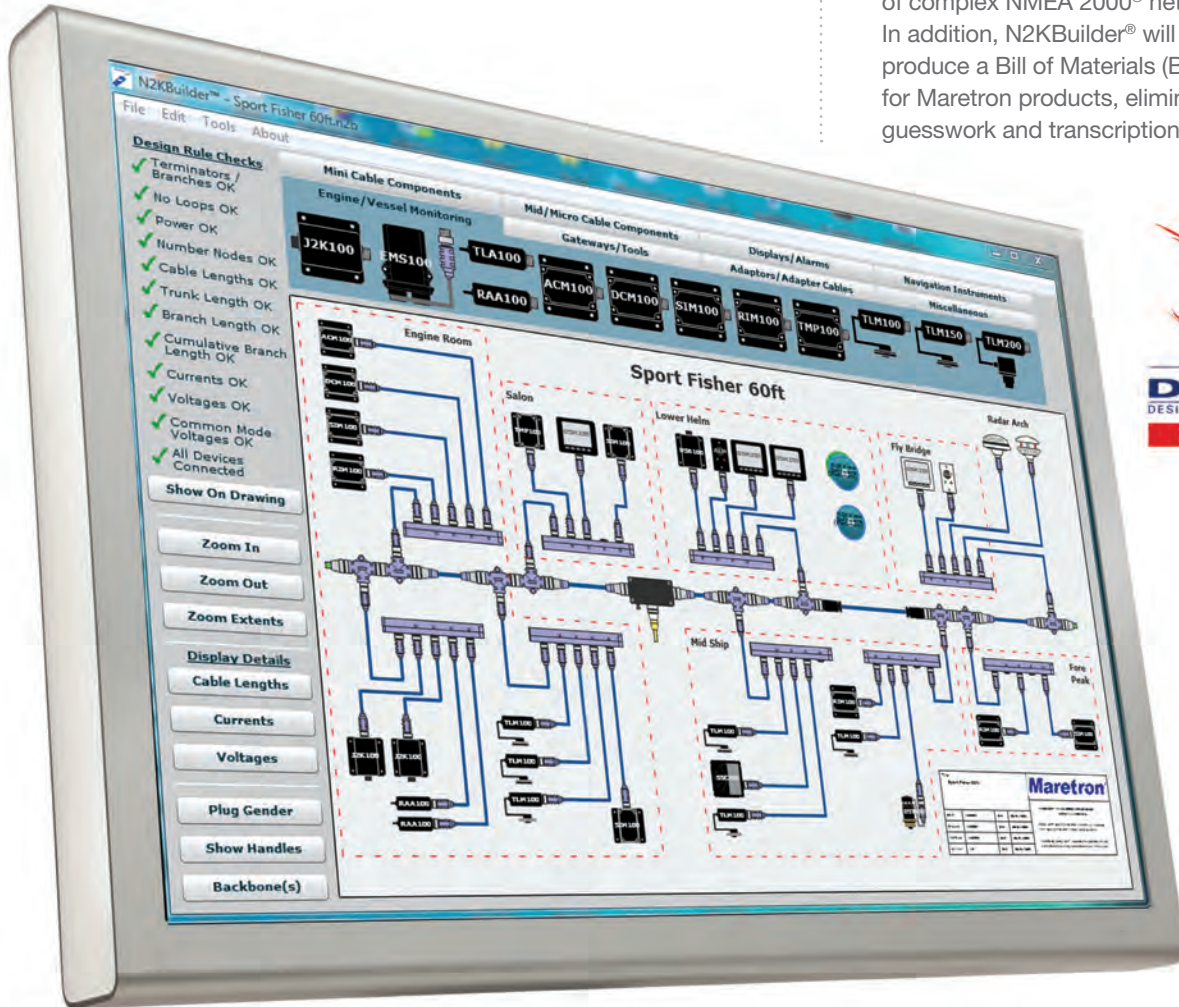

N2KAnalyzer® is a software tool, currently offered free of charge with the purchase of a Maretron NMEA 2000/USB gateway (USB100) or Maretron NMEA 2000/Ethernet gateway (IPG100), which gives you a detailed view of all of the devices on a NMEA 2000® network, and lets you perform a variety of configuration, updating, and troubleshooting tasks. All you need is a PC running Windows and a Maretron USB100 or IPG100 gateway.

N2KAnalyzer®

NMEA 2000® Network Analysis Software



Authorized Distributor

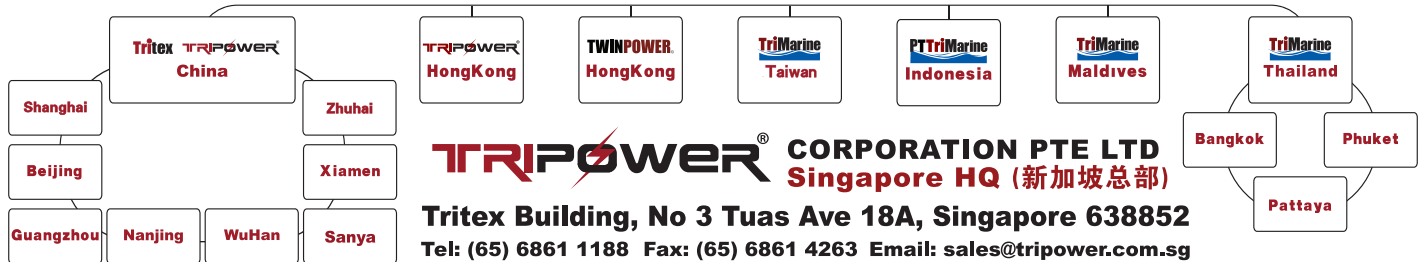

- | | | | |
|---|---|--|---|
| <p>上海 SHANGHAI
 Tel: (86) 21 6912 3208 / 186 2187 7951
 Fax: (86) 21 5917 5562
 Email: tripower-shanghai@tritex.com.cn</p> | <p>珠海 ZHUHAI
 Tel: (86) 756 6313 188 / 137 0968 7660
 Fax: (86) 756 6313 199
 Email: tritex-zhuhai@tritex.com.cn</p> | <p>香港 HONG KONG
 Tel: (852) 2341 3329 / 9411 1121
 Fax: (852) 2343 1830
 Email: hk-mgt@tripower.com.sg</p> | <p>台湾 TAIWAN
 Tel: (886) 7332 9388 / 9 1559 9665
 Fax: (886) 7333 9788
 Email: tw-sales@tritex.com.sg</p> |
| <p>北京 BEIJING
 Tel: (86) 10 8225 2799 / 135 7062 3310
 Fax: (86) 10 8225 3271
 Email: bj-admin@tritex.com.cn</p> | <p>三亚 SANYA
 Tel: (86) 898 8825 6551 / 147 1503 1584
 Fax: (86) 898 8825 6551
 Email: sanya-hainan@tritex.com.cn</p> | <p>马来西亚 MALAYSIA
 Tel: (65) 6861 1188
 Fax: (65) 6861 4263
 Email: sales@tripower.com.sg</p> | <p>曼谷 BANGKOK
 Tel: (66) 2175 6111 / 81 9008 774
 Fax: (66) 2175 6108
 Email: bkk-info@tritex.com.sg</p> |
| <p>广州 GUANGZHOU
 Tel: (86) 20 8769 7155 / 135 7062 1181
 Fax: (86) 20 8769 9296
 Email: gz-sales@tritex.com.cn</p> | <p>厦门 XIAMEN
 Tel: (86) 592 513 5359 / 159 5921 7720
 Fax: (86) 592 513 5250
 Email: xm-sales@Tritex.com.cn</p> | <p>越南 VIETNAM
 Tel: (65) 6861 1188
 Fax: (65) 6861 4263
 Email: sales@tripower.com.sg</p> | <p>普吉岛 PHUKET
 Tel: (66) 7636 4088 / 81 0856 116
 Fax: (66) 7636 4090
 Email: krattipat.tmit@gmail.com</p> |
| <p>南京 NANJING
 Tel: (86) 133 5773 7272
 Email: njzseapower@qq.com.</p> | <p>武汉 WUHAN
 Tel: (86) 182 7141 6829
 Email: wh-sales@tritex.com.cn</p> | <p>马尔代夫 MALDIVES
 Tel: (960) 333 6888 / 7781 818
 Fax: (960) 333 6884
 Email: trimarine@dhivehinet.net.mv</p> | <p>印度尼西亚 INDONESIA
 Tel: (62) 21 5512 635 / 8118 04595
 Fax: (62) 21 551 3382
 Email: pt-trimarine@tritex.com.sg</p> |